

# NEW PRODUCT NEWS

CHASE<sup>2</sup> HEPTA

expansion

## Inch Bore Type Cutter Introduction



TaeguTec's highly productive and economical 14-corner CHASE2HEPTA insert line is the best solution for cast iron and steel machining.

We are now introducing a new inch bore type face mill, as a standard item, to satisfy the increasing global demand for the CHASE2HEPTA 06 line.

#### INTRODUCTION

- **CHASE2HEPTA full line-up**
  - 09 size: available in both metric and inch bore types
  - 06 size: available in metric bore type with a newly added inch bore type
- **CHASE2HEPTA 06 line's inch bore type face mill diameter range: 63-160 mm**

# 14D-F45XN-06

## Face mill

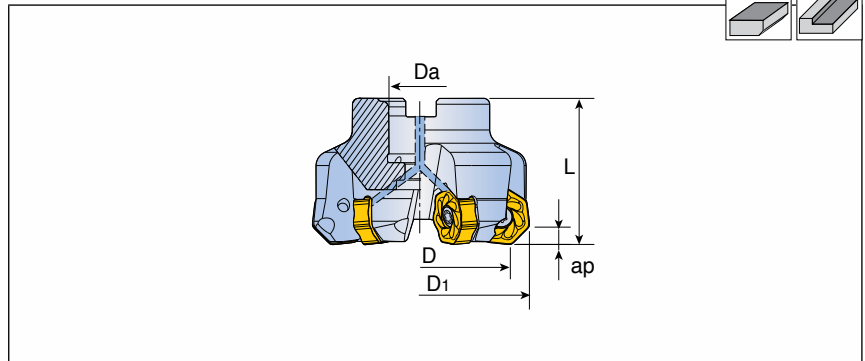

Designation		Dimension (mm)					Coolant	Arbor style	Kg	Mounting bolt	Insert
		D	D1	Da	L	ap					
<b>14D-F45XN 550-22R-06</b>	5	50	59.1	22	40	3.5	●	A	0.4	LH M10x1.5x25	XNM(H)U 0605...
<b>563-22R-06</b>	5	63	72.1	22	50	3.5	●	A	0.8	SH M10x1.5x25	
<b>763-22R-06</b>	7	63	72.1	22	50	3.5	●	A	0.8	SH M10x1.5x25	
<b>680-27R-06</b>	6	80	89.1	27	50	3.5	●	A	1.4	SH M12x1.75x35	
<b>980-27R-06</b>	9	80	89.1	27	50	3.5	●	A	1.4	SH M12x1.75x35	
<b>7100-32R-06</b>	7	100	109.1	32	50	3.5	●	A	2.1	SH M16x2x35	
<b>11100-32R-06</b>	11	100	109.1	32	50	3.5	●	A	2.1	SH M16x2x35	
<b>10125-40R-06</b>	10	125	134.1	40	63	3.5	●	A	3.6	SH M20x2.5x40	
<b>14125-40R-06</b>	14	125	134.1	40	63	3.5	●	A	3.6	SH M20x2.5x40	
<b>12160-40R-06</b>	12	160	169.1	40	63	3.5	X	C	4.7	-	
<b>16160-40R-06</b>	16	160	169.1	40	63	3.5	X	C	4.9	-	
<b>18160-40R-06</b>	18	160	169.1	40	63	3.5	X	C	5.0	-	
<b>14D-F45XN 763-25.4R-06 <span style="color:red">new</span></b>	7	63	72.1	25.4	50	3.5	●	A	0.8	SH M12x1.75x30	
<b>980-25.4R-06 <span style="color:red">new</span></b>	9	80	89.1	25.4	50	3.5	●	A	1.4	SH M12x1.75x35	
<b>11100-31.75R-06 <span style="color:red">new</span></b>	11	100	109.1	31.75	50	3.5	●	A	1.9	LH M16x2x35	
<b>14125-38.1R-06 <span style="color:red">new</span></b>	14	125	134.1	38.1	63	3.5	X	B	3.9	-	
<b>16160-50.8R-06 <span style="color:red">new</span></b>	16	160	169.1	50.8	63	3.5	X	B	5.0	-	

• Mounting bolt with coolant through hole is available on request (ordering example: SH M10x1.5x30-C)

## Spare parts

Designation	Screw	Wrench			
<b>14D-F45XN-06</b>	TS 40B100I	T-T15			