

DC - Vertretung und Auslieferungslager :

DC - Representative and Distributor :



DC SWISS SA

CH-2735 Malleray
Tel. +41 32 491 63 63
Fax +41 32 491 64 64
E-mail: info@dcswiss.ch



**THREADING
TECHNOLOGY**

www.dcswiss.com

DC SWISS SA
DE-EN-ID-2014



**THREADING
TECHNOLOGY**

www.dcswiss.com

**Gesamtkatalog
Main catalogue**
DE-EN-ID-2014



**THREADING
TECHNOLOGY**



Verfügbarkeit der Artikel

- ID** Identifikationsnummer, ab Lager lieferbar
- * ID** Identifikationsnummer, ab Lager lieferbar solange Vorrat

Availability of the articles

- ID** Identification number, available from stock
- * ID** Identification number, available from stock, while stock lasts

The management system of

DC Swiss SA

Grand rue 19 CP 363
2735 Malleray, Switzerland



has been assessed and certified as meeting the requirements of

ISO 9001:2008

For the following activities

**Cutting tool designer and manufacturer,
expert in Threading Technology.**

This certificate is valid from 7 September 2013 until 6 September 2016
and remains valid subject to satisfactory surveillance audits
Recertification audit due before 25 August 2016
Issue 4. Certified since September 2007

Authorised by



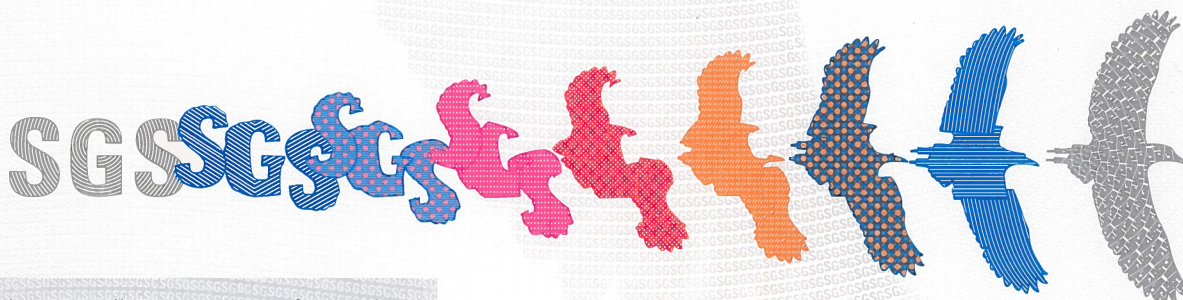

Accréditation N° SCESm 017

SGS Société Générale de Surveillance SA Systems & Services Certification
Technoparkstrasse 1 8005 Zurich Switzerland
t +41 (0)44 445-16-80 f +41 (0)44 445-16-88 www.sgs.com



K







 **VS**  **EL**
K613VS-3 **M**

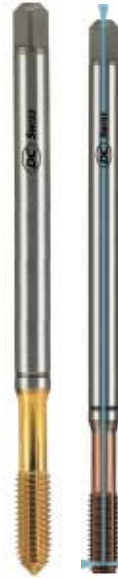

 **TiCN**
K313TC-3
K413TC-3 **MF**

FPS-FAS



 **VS** 
FPS581VS-3 **M**
FPS681VS-3

 **VS**  
FPS584VS-3 **M**
FPS684VS-3

 **VS** 
FAS581VS-3 **M**
FAS681VS-3

 **VS**  
FAS584VS-3 **M**
FAS684VS-3

W





 **DL**
W320DL-4 **M**
W420DL-4

 **R40**  **DL**
W360DL-3 **M**
W460DL-3 **G**
W460DL-5

FS







  **DL**  **E** 1.5 x P
FS380DL-5 **M**

  **DL**  **C** 2.5 x P
FS380DL-3 **M**

GW



 **2.5 x D_i**  **VS**
GW3016 \leq **M12**
GW3016VS **MF**

 **4 x D_i**  **VS**
GW3019 \leq $\frac{1}{2}$ **UNC**
GW3019VS \leq $\frac{3}{8}$ **UNF**

AERO



SA320-4 **UNJF 3B**

N Schaublin



N1110-3 **SV**
N1210-3
N5120



NEW

KODIERUNG - CODIFICATION

DC Gewindebohrer DC Taps

Beispiel - Example



Normale Werkstoffe	Normal materials	N							
Weiche Werkstoffe	Soft materials	W							
Zähe Werkstoffe	Tough materials	Z							
Hochfeste Werkstoffe	High tensile materials	H							
Sonderlegierte Werkstoffe	Special alloys	S							
Sonderlegierte Werkstoffe (Aero)	Special alloys (Aero)	SA							
Titanlegierungen (Aero)	Titanium alloys (Aero)	TL							
Grauguss und Alu-Guss	Cast iron and aluminium casting	GG							
Synchron-Gewindeschneiden	Rigid Tapping	RTS							
Spanbrecher	Swarf breaker	K							
MEGA-Gewindegrößen	MEGA tap sizes	MA							
Spezialausführung	Special execution		3						
Kurzer DIN-Schaft verstärkt	DIN short - reinforced shank						1		
Kurzer DIN-Schaft durchfallend	DIN short - reduced shank						2		
Langer DIN-Schaft verstärkt	DIN long - reinforced shank						3		
Langer DIN-Schaft durchfallend	DIN long - reduced shank						4		
Extra-langer DIN-Schaft verstärkt	DIN extra-long - reinforced shank						5		
Extra-langer DIN-Schaft durchfallend	DIN extra-long - reduced shank						6		
DC-Werksnorm	DC standards						9		
Kurzer ISO-Schaft verstärkt	ISO short - reinforced shank						11		
Kurzer ISO-Schaft durchfallend	ISO short - reduced shank						12		
Gerade Nuten	Straight flutes						1		
Gerade Nuten und Schälanschnitt	Straight flutes with spiral point						2		
Schälanschnitt	Spiral point						3		
Spiralnuten mit Linksdrall < 27°	< 27° left hand slow spiral flutes						4		
Spiralnuten mit Rechtsdrall < 27°	< 27° right hand slow spiral flutes						5		
Spiralnuten mit Rechtsdrall > 27°	> 27° right hand fast spiral flutes						6		
Spiralnuten mit Rechtsdrall > 40°	> 40° right hand fast spiral flutes						7		
Spiralnuten mit Rechtsdrall 10°, Schälän.	10° right hand fast spiral flutes, spiral point						9		
Standardausführung	Standard						0		
Ausgesetzte Zähne	Interrupted thread						1		
Verjüngtes Führungsgewinde	Truncated thread						2		
Innenkühlung	Internal coolant						3		
Ausgesetzte Zähne, Innenkühlung	Interrupted thread, internal coolant						4		
Verjüngtes Führungsgewinde, Innenkühlung	Truncated thread, internal coolant						5		
"V"-Oberflächenbehandlung	"V" surface treatment							V	
Verschleisschutzschicht	Wear-protective coating							VS	
Titannitrid-Beschichtung (TiN)	Titanium-nitride coating (TiN)							TN	
Titancarbonitrid-Beschichtung (TiCN)	Titanium carbonitride coating (TiCN)							TC	
Plasmanitrierung + "V"-Oberflächenbehandlung	Plasma nitriding + "V" surface treatment							NV	
DLC-Beschichtung	DLC-coating							DL	
Hardlube-Beschichtung	Hardlube-coating							HL	
Vorschneider	Taper tap								=1
Mittelschneider	Second tap								=2
Fertigschneider / 2 - 3 Gewindegänge	Bottoming tap / 2 - 3 chamfered threads								=3
3.5 - 5 Gewindegänge, Schälanschnitt	3.5 - 5 chamfered threads, spiral point								=4
1.5 - 2 Gewindegänge	1.5 - 2 chamfered threads								=5
6 - 8 Gewindegänge	6 - 8 chamfered threads								=8
Gewindebohrer-Satz	Thread taps set								=S

KODIERUNG - CODIFICATION





















DC Gewindeformer DC Thread formers

Beispiel - Example



Standard Polygonform $\lt; \varnothing 3 \text{ mm}$	Standard polygon form $\lt; \varnothing 3 \text{ mm}$	FS							
Passive Polygonform $\geq \varnothing 3 \text{ mm}$	Passive polygon form $\geq \varnothing 3 \text{ mm}$	FPS							
Aktive Polygonform $\geq \varnothing 3 \text{ mm}$	Active polygon form $\geq \varnothing 3 \text{ mm}$	FAS							
Spezialausführung	Special execution		3						
Langer DIN-Schaft verstärkt	DIN long - reinforced shank			3					
Langer DIN-Schaft durchfallend	DIN long - reduced shank			4					
Extra-langer DIN-Schaft verstärkt	DIN extra-long - reinforced shank			5					
Extra-langer DIN-Schaft durchfallend	DIN extra-long - reduced shank			6					
Gewindeformer	Thread former				8				
Ohne Schmiernuten	Without lubrication grooves					0			
Mit Schmiernuten	With lubrication grooves					1			
Innenkühlung mit seitlichem Austritt	Internal coolant with radial outflow					4			
Verschleisschutzschicht	Wear-protective coating							VS	
Chromnitrid-Beschichtung (CrN)	Chromenitride coating (CrN)							CN	
DLC-Beschichtung	DLC-coating							DL	
2 - 3 Gewindegänge	2 - 3 chamfered threads								-3
1.5 - 2 Gewindegänge	1.5 - 2 chamfered threads								-5

PIKTOGRAMME - PICTOGRAPHS

	Verstärkter Schaft gemäss DIN 371 Reinforced shank as per DIN 371		Gewindeformer Thread former
	Durchfallender Schaft gemäss DIN 376 Reduced shank as per DIN 376		Gewindeformer mit Schmiernuten Thread former with lubrication grooves
	HSSE HSSE		Vorschneider Taper tap
	HSSE-PM HSSE-PM		Mittelschneider Second tap
	Anzahl Spannuten (Z) Number of flutes (Z)		Fertigschneider Bottoming tap
	Gerade Nuten Straight flutes		Handgewindebohrer, Satz zu 2 Stück Hand taps, set of 2 pieces
	Gerade Nuten und Schälanschnitt Straight flutes with spiral point		Handgewindebohrer, Satz zu 3 Stück Hand taps, set of 3 pieces
	Schälanschnitt Spiral point only		Führungszapfen Parallel pilot
	Spiralnuten mit 40° Rechtsdrill 40° right hand spiral flutes		Innenkühlung mit stirnseitigem Schmiermittelaustritt Internal coolant with frontal outflow
	Verjüngtes Führungsgewinde Truncated thread		Innenkühlung mit seitlichem Schmiermittelaustritt Internal coolant with radial outflow
	Ausgesetzte Zähne Interrupted thread		

PIKTOGRAMME - PICTOGRAPHS



Für Werkstoffgruppen gemäss
DC-Anwendungstabelle

For material groups as per **DC**
 application chart

12
1.0037 S137-2 (S235JR)
1.0050 S150-2 (E295)
1.0060 S160-2 (E335)
1.5919 15CrNi6
1.7131 16MnCr5

22
1.4301 X5CrNi18-10
1.4406 X2CrNiMoN17-12-2
1.4435 X2CrNiMo18-14-3
1.4541 X6CrNiTi18-10
1.4571 X6CrNiMoTi17-12-2



Extra-lang
 Extra-long



Durchgangsloch, langspanende Werkstoffe
 Through hole, long chipping materials



Durchgangsloch < 1.5 x D, kurzspanende Werkstoffe
 Through hole < 1.5 x D, short chipping materials



Sackloch < 1.5 x D, langspanende Werkstoffe
 Blind hole < 1.5 x D, long chipping materials



Sackloch < 2.5 x D, kurzspanende Werkstoffe
 Blind hole < 2.5 x D, short chipping materials



Durchgangs- und Sackloch < 2.5 x D
 Through / blind hole < 2.5 x D



Sackloch < 3 x D
 Blind hole < 3 x D



MEGA-Gewindeschneidkopf
 MEGA thread tapping head



Kronengewindebohrer
 Crown tap



Kombi-Gewindebohrer
 Combination drill/tap



Kernlochdurchmesser
 Core hole diameter



Radius auf Aussendurchmesser
 Radius on external diameter



Konisches Gewinde 1:16 (NPT - NPTF - Rc)
 Tapered thread 1:16 (NPT - NPTF - Rc)



EG-Gewinde
 Thread EG



Linksgewinde
 Left hand thread



3.5 - 5 Gewindegänge, Form B
 3.5 - 5 chamfered threads, form B



2 - 3 Gewindegänge, Form C
 2 - 3 chamfered threads, form C



1.5 - 2 Gewindegänge, Form E
 1.5 - 2 chamfered threads, form E



Toleranzklasse ISO 2 6H
 Tolerance class ISO 2 6H



Toleranzklasse ISO 2 6H + 0.1 mm
 Tolerance class ISO 2 6H + 0.1 mm



Toleranzklasse ISO 3 6G
 Tolerance class ISO 3 6G



DC -"V"-Oberflächenbehandlung
DC "V" surface treatment



DC -Verschleisschutzschicht
DC wear-protective coating



Titannitrid-Beschichtung
 Titanium-nitride coating



Titancarbonitrid-Beschichtung
 Titanium-carbonitride coating



Plasmanitrierung + "V"-Oberflächenbehandlung
 Plasma nitriding + "V" surface treatment



Chromnitrid-Beschichtung
 Chromenitride coating



DLC-Beschichtung
 DLC-coating



Hardlube-Beschichtung
 Hardlube-coating



Spanfragmente / regelmässige Spanaufteilung
 Swarf fragments / consistant chips



Für klassisches Gewindeschneiden
 For Classic Tapping



Für synchrones Gewindeschneiden
 For Rigid Tapping

ANWENDUNGSGRUPPEN

APPLICATION GROUPS

Beispiele für Anwendungsgruppen

Examples for application groups

11 Automatenstahl 1.0711 9S20 1.0715 9SMn28 1.0718 9SMnPb28 1.0726 35S20 1.0737 9SMnPb36	12 Baustahl, Einsatzstahl 1.0037 Si37-2 (S235JR) 1.0050 Si50-2 (E295) 1.0060 Si60-2 (E335) 1.5919 15CrNi6 1.7131 16MnCr5	13 Kohlenstoffstahl 1.0503 C45 1.0535 C55 1.0601 C60 1.1545 C10SW1 1.2067 102Cr6 (100Cr6)	14 Stahl legiert < 850 N/mm ² 1.2363 X100CrMoV5-1 1.3551 80MoCrV42-16 1.7218 25CrMo4 1.7220 34CrMo4 1.7225 42CrMo4	11 Free-cutting steels 1.0711 1212 1.0715 1213 1.0718 12L13 1.0726 1140 1.0737 12L14	12 Structural, cementation steels 1.0037 1015 1.0050 A570 Gr.50 1.0060 A572 Gr.65 1.5919 3115 1.7131 5115	13 Carbon steels 1.0503 1045 1.0535 1055 1.0601 1060 1.1545 W110 1.2067 L 3	14 Alloy steels < 850 N/mm ² 1.2363 A2 1.3551 M50 1.7218 4130 1.7220 4135 1.7225 4140
15 Stahl legiert / vergütet > 850 - < 1150 N/mm ² 1.3553 X82WCrV6-5-4 1.6580 30CrNiMo8 1.7220 34CrMo4 1.7225 42CrMo4v 1.8507 34CrAlMo5	16 Hochfester Stahl EN-GJS-1200-2 1.6582 34CrNiMo6v 1.7225 42CrMo4v 1.7228 50CrMo4v 1.8515 31CrMo12v	21 Rostfreier Stahl, geschwefelt 1.4005 X12CrS13 1.4104 X14CrMoS17 1.4305 X10CrNiS18-9	22 Austenitisch 1.4301 X5CrNi18-10 1.4406 X2CrNiMoN17-12-2 1.4435 X2CrNiMo18-14-3 1.4541 X6CrNiTi18-10 1.4571 X6CrNiMoTi17-12-2	15 Alloy steels hard./temp. > 850 - < 1150 N/mm ² 1.3553 - 1.6580 4340 1.7220 4135 1.7225 4140 1.8507 A355CLD (K23510)	16 High tensile alloy steels EN-GJS-1200-2 1.6582 4340 1.7225 4140 1.7228 4150 1.8515 -	21 Free machining stainless steels 1.4005 416 1.4104 430F 1.4305 303	22 Austenitic stainless steels 1.4301 304 1.4406 316LN 1.4435 316L 1.4541 321 1.4571 316Ti
23 Ferritisch, martensitisch < 850 N/mm ² 1.4112 X90CrMoV18 1.4540 X4CrNiCuNb16-4 1.4582 X4CrNiMoNb25-7 1.4762 X10CrAl24 1.4922 X20CrMo11-1	24 Ferritisch, martensitisch > 850 - < 1150 N/mm ² 1.4057 X17CrNi17-2 1.4125 X105CrMo17 1.4542 X5CrNiCuNb16-4 1.4548 X5CrNiCuNb17-4-4 1.4748 X85CrMoV18-2	31 Grauguss 0.6015 GG15 0.6020 GG20 0.6025 GG25 0.6030 GG30	32 Kugelgraphitguss, Temperguss 0.7040 GGG40 0.7043 GGG40.3 0.7050 GGG50 0.7060 GGG60 0.7080 GGG80	23 Ferritic and martensitic < 850 N/mm ² 1.4112 440B 1.4540 XM12 (15-5PH) 1.4582 - 1.4762 446 1.4821 4922	24 Ferritic and martensitic > 850 - < 1150 N/mm ² 1.4057 431 1.4125 440C 1.4542 630 (17-4PH) 1.4748 -	31 Cast iron 0.6015 A48-25B 0.6020 A48-30B 0.6025 A48-40B 0.6030 A48-45B	32 Spheroidal graphite + malleable cast iron 0.7040 60-40-18 0.7043 - 0.7050 65-45-12 0.7060 80-55-06 0.7080 120-90-02
41 Reintitan 3.7024 Grad1 3.7034 Grad2 3.7055 Grad3 3.7065 Grad4	42 Titanlegierung 3.7124 TiCu2.5 Ti6Al7Nb 3.7164 TiAl6V4 (Grad5) 3.7174 TiAl6V6Sn2	51 Nickellegierung 1 < 850 N/mm ² 1.3912 Ni36 (Invar) 2.4360 NiCu30Fe (Monel 400) 2.4816 NiCr15Fe (Inconel 600) 1.4876 X10NiCrAlTi32-20	52 Nickellegierung 2 > 850 - < 1150 N/mm ² 2.4375 NiCu30Al (MonelK500) 2.4631 NiCr20TiAl (Nimonic 80) 2.4668 NiCr19NbMo (Inconel 718)	41 Pure titanium 3.7024 Gr.1 3.7034 Gr.2 3.7055 Gr.3 3.7065 Gr.4	42 Titanium alloys 3.7124 Alloy 230 F-1295 3.7164 Gr.5 3.7174 -	51 Nickel alloys 1 < 850 N/mm ² 1.3912 K93600 2.4360 N04400 1.4816 N08800	52 Nickel alloys 2 > 850 - < 1150 N/mm ² 2.4375 N05500 (B865) 2.4631 N07080 (B637) 2.4668 N07718 (B637)
53 Nickellegierung 3 > 1150 - ≤ 1600 N/mm ² 2.4631 NiCr20TiAl (Nimonic80) 2.4668 NiCr19NbMo (Inconel718)	61 Reinkupfer (Elektrolytkupfer) 2.0060 E-Cu57 (E-Cu)	62 Messing, Bronze, Rotguss (kurzspanend) 2.0401 CuZn39Pb3 (Ms58) 2.0402 CuZn40Pb2 (Ms58) 2.1030 CuSn8 (Bz) 2.1096 G-CuSn5ZnPb	63 Messing (langspanend) 2.0240 CuZn15 (Ms85) 2.0265 CuZn30 (Ms70) 2.0321 CuZn37 (Ms63)	53 Nickel alloys 3 > 1150 - ≤ 1600 N/mm ² 2.4631 N07080 (B637) 2.4668 N07718 (B637)	61 Pure copper (electrolytic copper) 2.0060 C11000	62 Short chip brass + phosphor-bronze + gun metal 2.0401 C38500 2.0402 C37800 2.1030 C52100 2.1096 -	63 Long chip brass 2.0240 C23000 2.0265 C26000 2.0321 C27200
71 Al unlegiert 3.0205 Al99 3.0255 Al99.5	72 Al legiert Si < 1.5% 3.1255 AlCuSiMn 3.1355 AlCuMg2 3.2315 AlMgSi1 3.3206 AlMgSi0.5 3.4345 AlZnMgCu0.5	73 Al legiert Si > 1.5% - < 10% 3.2161 G-AlSi8Cu3 3.2162 GD-AlSi8Cu3 3.2341 G-AlSi5Mg 3.2371 G-AlSi7Mg	74 Al legiert Si > 10% Mg-Legierung 3.2381 G-AlSi10Mg 3.2382 GD-AlSi10Mg 3.2581 G-AlSi12 3.2583 G-AlSi12 (Cu)	71 Al unalloyed 3.0205 1200 3.0255 1050A	72 Al alloyed Si < 1.5% 3.1255 2014 3.1355 2024 3.2315 6082 3.3206 6060 3.4345 7020	73 Al alloyed Si > 1.5% - < 10% 3.2161 380.1 3.2162 - 3.2341 - 3.2371 A 356.2	74 Al alloyed Si > 10% Mg-alloys 3.2381 A360 3.2382 - 3.2581 A413 3.2583 413.1
81 Thermoplaste Delrin (POM) Teflon Nylon	82 Duroplaste Bakelit Novopan	83 Faserverstärkte Kunststoffe Glasfaserverstärkte Thermo- und Duroplaste	Referenz: DIN	81 Thermoplastics Delrin (POM) Teflon Nylon	82 Duroplastics Bakelit Novopan	83 Glass fibre reinforced plastics Glass fibre reinforced, Thermo and Duroplastics	Referenz: AISI/ASTM/UNS

ANWENDUNGSTABELLE - APPLICATION CHART

GEWINDESCHNEIDEN - THREAD CUTTING

Gewindeschneiden Thread cutting

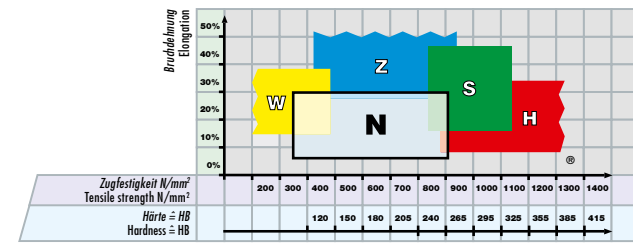

Gewindeschneiden Thread cutting

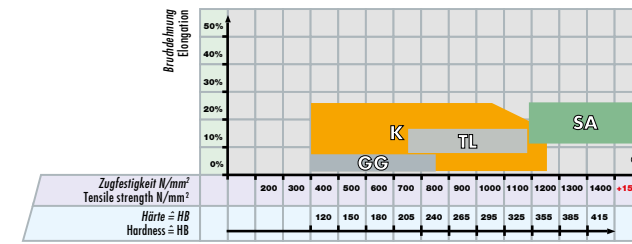

Synchron-Gewindeschneiden Rigid Tapping

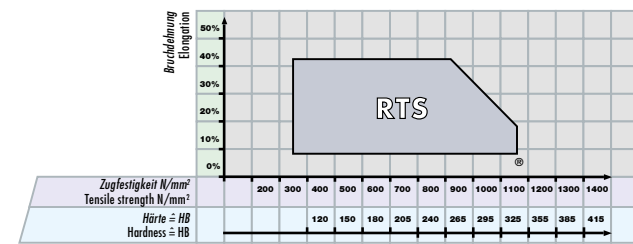

Gewindeformen Thread forming

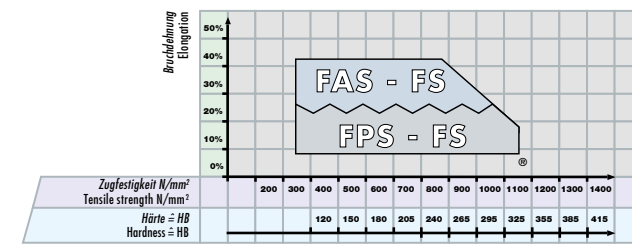

Anwendungsgruppen Material classification

Werkstoff-Gruppen Material groups	Werkstoffbezeichnung Material designation	Material designation	Härte Hardness (HB)	Festigkeit Tensile strength Rm (N/mm ²)	Dehnung Elongation A (%)
10 Stahl Steels	11 Automatenstahl	Free-cutting steels	< 200	< 700	< 10
	12 Baustahl, Einsatzstahl	Structural / cementation steels	< 200	< 700	< 30
	13 Kohlenstoffstahl	Carbon steels	< 300	< 1000	< 20
	14 Stahl legiert <850 N/mm²	Alloy steels <850 N/mm ²	< 250	< 850	< 30
	15 Stahl legiert / vergütet >850 - <1150 N/mm²	Alloy steels hard./temp. >850 - <1150 N/mm ²	> 250	> 850	< 30
	16 Hochfester Stahl	High tensile alloy steels	> 250	> 850	< 12
20 Rostfreier Stahl Stainless Steels	21 Rostfreier Stahl / geschwefelt	Free machining stainless steels	< 250	< 850	< 25
	22 Austenitisch	Austenitic stainless steels	< 250	< 850	> 20
	23 Ferritisch, martensitisch <850 N/mm²	Ferritic and martensitic <850 N/mm ²	< 250	< 850	> 20
	24 Ferritisch, martensitisch >850 - <1150 N/mm²	Ferritic and martens. >850 - <1150 N/mm ²	> 250	> 850	> 15
30 Guss Cast iron	31 Grauguss	Cast iron	< 250	< 850	< 10
	32 Kugelgraphitguss, Temperguss	Spheroidal graphite + malleable cast iron	< 250	< 850	> 10
40 Titan Titanium	41 Reintitan	Pure titanium	< 250	< 850	> 20
	42 Titanlegierung	Titanium alloys	> 250	> 850	< 20
50 Nickel Nickel	51 Nickellegierung 1 <850 N/mm²	Nickel alloys 1 <850 N/mm ²	< 250	< 850	> 25
	52 Nickellegierung 2 >850 - <1150 N/mm²	Nickel alloys 2 >850 - <1150 N/mm ²	> 250	> 850	< 25
	53 Nickellegierung 3 >1150 - ≤1600 N/mm²	Nickel alloys 3 >1150 - ≤1600 N/mm ²	> 340	> 1150	< 20
60 Kupfer Copper	61 Reinkupfer (Elektrolytkupfer)	Pure copper (electrolytic copper)	< 120	< 400	> 12
	62 Messing, Bronze, Rotguss (kurzspanend)	Short chip brass, phosphor bronze, gun metal	< 200	< 700	< 12
	63 Messing (langspanend)	Long chip brass	< 200	< 700	> 12
70 Aluminium Magnesium Aluminium Magnesium	71 Al unlegiert	Al unalloyed	< 100	< 350	> 15
	72 Al legiert Si < 1.5 %	Al alloyed Si < 1.5 %	< 150	< 500	> 15
	73 Al legiert Si > 1.5 % - < 10 %	Al alloyed Si > 1.5 % - < 10 %	< 120	< 400	< 15
	74 Al legiert Si > 10 %, Mg-Legierung	Al alloyed Si > 10 %, Mg-Alloys	< 120	< 400	< 10
80 Kunststoff Plastic compounds	81 Thermoplaste	Thermoplastics	-	-	-
	82 Duroplaste	Duroplastics	-	-	-
	83 Faserverstärkte Kunststoffe	Glass fibre reinforced plastics	-	-	-

Ab Seite :
From page :
M
MF
UNC/UNC(J)
UNF/UNJF/UNF(J)
UNEF/UN/UNS
G/Rp/Rc
W / SV
NPT/NPTF
PG/TR
EG M/EG UNC/EG UNF

N Normale Werkstoffe Normal materials												W Weiche Werkstoffe Soft materials			
22	22	24	24	24	32	32	34	34	34	34		46	46	47	47
85	84	85	85		84		91	91	91						
114	114	114					116	116							
134	134	134					136	136							
150	150						151	151							
156	157	157	157				158	158	158					159	159
166	166														
170															
172	172														
	176	176						177	177						



Vc (m/min) < Ø 20 mm Guide line	Standard +V / +NV		Beschichtet Coated TN / TC / DL / VS		N 10	N 20	N 20V	N 20TN	N 20TC	N 50	N 50V	N 60	N 60V	N 60TN	N 60TC	W 20	W 20DL	W 60	W 60DL	
	Standard	+V / +NV	Beschichtet	Coated																
10-15		20-30																		
10-15		20-30																		
8-12		16-24																		
8-12		16-24																		
3-5		6-12																		
3-5		3-5																		
10-15		20-30																		
2-6		6-12																		
2-6		6-12																		
		4-8																		
10-15		20-30																		
10-15		20-30																		
4-8		4-8																		
3-5		3-5																		
3-5		6-12																		
		4-8																		
2-3																				
8-12		12-16																		
20-30																				
16-24																				
10-15		20-30																		
20-30		20-30																		
10-15		20-30																		
10-15		20-30																		
20-30																				
8-16		16-24																		
4-8		8-16																		

GEWINDEFORMEN - THREAD FORMING

FS Standard < Ø 3 mm		FPS Passive Polygonform Passive polygon form					FAS Aktive Polygonform Active polygon form		
68	69	70	70	70	70	72	73	73	74
			104			104		105	
127						127		127	
147						147		147	
						162		162	



Vc (m/min)
< Ø 20 mm
(Guide line)
Beschichtet VS + CN
Coated VS + CN

	FS. 80VS	FS. 80DL	FPS. 80CN	FPS. 81CN	FPS. 80VS	FPS. 81VS	FPS. 84VS	FAS. 80VS	FAS. 81VS	FAS. 84VS	
20 - 40	S	S			SE	SE	SE				11
20 - 40	SE	S			SE	SE	SE	SE	SE	SE	12
20 - 30	SE	S			SE	SE	SE	SE	SE	SE	13
20 - 30	S	S			SE	SE	SE	SE	SE	SE	14
10 - 15	S				S	S	SE	S	S	SE	15
											16
10 - 20	S	SE			S	S	SE	S	S	SE	21
10 - 15		SE						SE	SE	SE	22
6 - 12		SE						S	S	SE	23
6 - 12		S			S	S	S	SE	SE	SE	24
											31
											32
10 - 20		S						S	S	S	41
											42
10 - 15		S						SE	SE	SE	51
											52
											53
10 - 20	S	S						SE	SE	SE	61
											62
20 - 30	SE	SE	SE	SE	S	S	S	S	S	S	63
20 - 40		SE	SE	SE							71
20 - 40		SE	SE	SE							72
20 - 40		SE	SE	SE							73
											74
											81
											82
											83













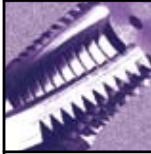

S Optimal mit Schneidöl
S Geeignet mit Schneidöl

S Optimal with cutting oil
S Suitable with cutting oil

E Optimal mit Emulsion
E Geeignet mit Emulsion

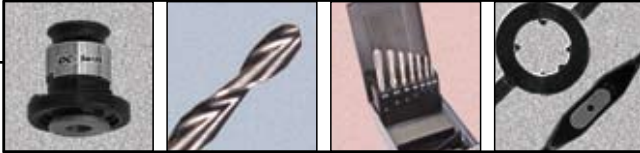
E Optimal with emulsion
E Suitable with emulsion

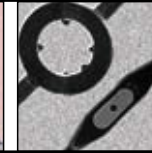
	<p>Gewindeschneiden Thread Cutting</p> 		<p>Synchron-Gewindeschneiden Rigid Tapping</p> 
<p>M</p> <p>N 22-45/76-78/285 W 46-47 Z 48-51 H 52-55</p> <p>S 56-57 SA 57-59 TL 58-59 GG 60-61</p> <p>K 66-67</p> <p>MF</p> <p>N 84-93/106-108 Z 94-95 H 96-97 S 98</p> <p>SA 99-101 TL 100-101 K 103</p> <p>UNC, UNC(J)</p> <p>N 114-117/128-129 Z 118-120 H 121 S 122-123</p> <p>SA 124-125 TL 124</p> <p>UNF, UNF(J), UNJF, UNEF, UN, UNS</p> <p>N 134-137/148-151 Z 138-139 H 140-141 S 142</p> <p>SA 143-145 TL 143-144</p> <p>G (BSP), Rp, Rc, W, SV Schaublin</p> <p>N 156-158/163-167 W 159 Z 160-161 H 159</p> <p>GG 159</p> <p>NPT, NPTF, PG, TR</p> <p>N 170-173</p> <p>EG M, EG UNC, EG UNF</p> <p>N 176-177/180/183 Z 181/184 S 184 SA 178-179/182/184-185</p> <p>TL 178/182/185</p>		<p>M</p> <p>RTS 62-65 Z.70/Z.73 50-51 K 66-67</p> <p>MF</p> <p>RTS 102 Z.70 94-95 K 103</p> <p>UNC</p> <p>RTS 126 Z.70 120</p> <p>UNF</p> <p>RTS 146 Z.70 139</p> <p>G (BSP)</p> <p>RTS 161 Z.70 161</p> <p>EG UNC, EG UNF</p> <p>Z.70 181/184</p>	
			<p>Gewindeformen Thread Forming</p> 
 <p>Kronengewindebohrer Crown taps</p> 		 <p>Kombi-Gewindebohrer Combination drill/taps</p> 	
<p>M, MF</p> <p>N 187-188</p> <p>UN, G (BSP)</p> <p>N 189</p>		<p>M, MF</p> <p>N 192</p> <p>UNC, G (BSP), PG</p> <p>N 193</p>	

 <p>Gewindewirbeln Thread Whirling</p> 	 <p>Gewindelehren Thread gauges</p> 
<p>S, M, MF, UNC, UNF GW 206-213</p>	<p>M D 266-267</p>
 <p>Gewindefräsen Thread Milling</p> 	<p>MF D 268-271</p>
<p>M GF 214-216 GFH 214 GFS 225-227 GFM 236 BGF 240-242</p> <p>MF GF 217-218 GFS 228-229 GFM 236 BGF 243</p> <p>UNC, UNF, UNEF, UN, UNS GF 219-222 GFS 230-233 GFM 237</p> <p>G (BSP), PG GF 223 GFS 234 GFM 238</p> <p>NPT, NPTF GF 224 GFS 235 GFM 239</p>	<p>UNC, UNF, UNEF D 272-273</p> <p>G (BSP), PG D 274</p> <p>NPT, NPTF D 275</p> <p>EG M, EG UNC, EG UNF D 276</p>
 <p>Schneideisen Dies</p> 	 <p>Gewindeschneidfutter SRT Tapping chucks SRT</p> 
<p>M N 246/260/262/263 Z 247/260</p>	<p>HSK 278 BT40 278 SK40/SK50 279 DIN1835 B 280-281</p>
<p>MF N 248-250/261/262 Z 248-249</p>	   
<p>UNC, UNF, UNEF, UN, UNS N 251-253</p> <p>G (BSP), R N 254/256/263 Z 255 MS 255</p> <p>NPT, NPTF, PG, TR, W / W Schaublin N 257-259/263 N 167</p>	<p>D 282/283 F 284 D 285 D 286-287</p>
<p>M N 246/260/262/263 Z 247/260</p>	
<p>MF N 248-250/261/262 Z 248-249</p> <p>UNC, UNF, UNEF, UN, UNS N 251-253</p> <p>G (BSP), R N 254/256/263 Z 255 MS 255</p> <p>NPT, NPTF, PG, TR, W / W Schaublin N 257-259/263 N 167</p>	<p><i>Schnittgeschwindigkeiten, Vergleichstabelle, Kernlochbohrungen, Bolzendrehdurchmesser Technischer Fragebogen Liefer- und Zahlungsbedingungen</i></p> <p>Cutting speeds, conversion tables, core hole diameters, turned diameters Technical questionnaire Delivery and payment conditions</p>

M

MF

UNC, UNF, UNEF, UN, UNS

UNC, UNF, UNEF, UN, UNS



G, Rp, Rc, W, SV

NPT, NPTF, PG, TR























EG M, EG UN

























Kronengewindebohrer
Crown taps

























Kombi-Gewindebohrer
Combination drill/taps





















		N													
Merkmale Characteristics															
					V		TiN TiCN						V		
															
Lochart Hole type															
		N310-3	N320-3 N320-4	N320V-3 N320V-4	N320TN-3/4 N320TC-3/4	N321-3 N321-4	N330-3 N330-4	N330V-3 N330V-4							
DIN lang DIN long	DIN 371	22	22/24	24	24	30	30	30							
Extra-lang Extra-long	DC														
ISO kurz ISO short	ISO 529														
DIN kurz DIN short	DIN 352														
DIN lang DIN long	~DIN 2174														
Toleranz Tolerance	ISO 2 6H	22	22/24	24	24	30	30	30							
Übermass Oversize	ISO 3 6G		28	28											
Übermass Oversize	7G		28												
Übermass Oversize	+ 0.10 mm + 0.20 mm		28												
Feintoleranz Fine tolerance	ISO 1 4H		26												
LH Linksgewinde LH Left hand thread	ISO 2 6H	22	26	26											
		N410-3	N420-4	N420V-4	N420TN-4 N420TC-4	N421-4	N430-4	N430V-4							
DIN lang DIN long	DIN 376	23	25	25	25	31	31	31							
Extra-lang Extra-long	DC														
ISO kurz ISO short	ISO 529														
DIN kurz DIN short	DIN 352														
DIN lang DIN long	~DIN 2174														
Toleranz Tolerance	ISO 2 6H	23	25	25	25	31	31	31							
Übermass Oversize	ISO 3 6G		29	29											
Übermass Oversize	7G		29												
Übermass Oversize	+ 0.10 mm + 0.20 mm		29/31												
Feintoleranz Fine tolerance	ISO 1 4H		27												
LH Linksgewinde LH Left hand thread	ISO 2 6H	23	27	27											



N





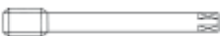

















 R15  V	 R40	 R40  V	 R40 TiN TiCN	 R40 V E 1.5xP	 R40 	 R40  V		 V
								
N350-3 N350V-3	N360-3	N360V-3	N360TN-3 N360TC-3	N360-5 N360V-5	N361-3	N362V-3	N520-4	N520V-4
32	34	34	34	40	40	40	42	42
32	34	34	34	40	40	40	42	42
	36	36						
	38	38						
	38							
	36	36						
N450-3 N450V-3	N460-3	N460V-3	N460TN-3 N460TC-3	N460-5 N460V-5	N461-3	N462V-3	N620-4	N620V-4
33	35	35	35	41	41	41	43	43
33	35	35	35	41	41	41	43	43
	37	37						
	39	39						
	39							
	37	37						

		N								
Merkmale Characteristics		 TiN	 R40	 R40	 V	 R40	 TiN		 R40	
										
Lochart Hole type										
		N520TN-4	N560-3	N560V-3	N560TN-3	N1120-4	N1160-3	N1110 -1-2-3-S		
DIN lang DIN long	DIN 371									
Extra-lang Extra-long	DC	42	44	44	44					
ISO kurz ISO short	ISO 529					78	78			76
DIN kurz DIN short	DIN 352									
DIN lang DIN long	~DIN 2174									
Toleranz Tolerance	ISO 2 6H	42	44	44	44	78	78			76
Übermass Oversize	ISO 3 6G									
Übermass Oversize	7G									
Übermass Oversize	+ 0.10 mm + 0.20 mm									
Feintoleranz Fine tolerance	ISO 1 4H									
LH Linksgewinde LH Left hand thread	ISO 2 6H									
		N620TN-4	N660-3	N660V-3	N660TN-3	N1220-4	N1260-3	N1210 -1-2-3-S		
DIN lang DIN long	DIN 376									
Extra-lang Extra-long	DC	43	45	45	45					
ISO kurz ISO short	ISO 529					78	78			77
DIN kurz DIN short	DIN 352									
DIN lang DIN long	~DIN 2174									
Toleranz Tolerance	ISO 2 6H	43	45	45	45	78	78			77
Übermass Oversize	ISO 3 6G									
Übermass Oversize	7G									
Übermass Oversize	+ 0.10 mm + 0.20 mm									
Feintoleranz Fine tolerance	ISO 1 4H									
LH Linksgewinde LH Left hand thread	ISO 2 6H									

	W				Z			
		 DL	 R40	 R40 DL	 V	 VS	 R40 V	 R40 VS
		 NEW		 NEW				
								
	W320-3 W320-4	W320DL-3 W320DL-4	W360-3	W360DL-3	Z320V-3 Z320V-4	Z320VS-4	Z360V-3 Z362V-3	Z360VS-3 Z362VS-3
	46	46	47	47	48	48	49	50
	46	46	47	47	48	48	49	50
	W420-4	W420DL-4	W460-3	W460DL-3	Z420V-4	Z420VS-4	Z462V-3	Z462VS-3
	46	46	47	47	48	48	49	51
	46	46	47	47	48	48	49	51

		Z	H	S	SA			
Merkmale Characteristics		 VS	 VS	 TiCN	 VS	 VS		
								
Lochart Hole type								
		Z370VS-3	Z373VS-3	H320-4 H320TC-4	H350-3 H350TC-3	S320VS-4	S360VS-3	SA320-4
<i>DIN lang</i> DIN long	DIN 371	50	50	52	54	56	57	58
<i>Extra-lang</i> Extra-long	DC							
<i>ISO kurz</i> ISO short	ISO 529							
<i>DIN kurz</i> DIN short	DIN 352							
<i>DIN lang</i> DIN long	~DIN 2174							
<i>Toleranz</i> Tolerance	ISO 2 6H	50	50	52	54	56	57	58
<i>Übermass</i> Oversize	ISO 3 6G				54			
<i>Übermass</i> Oversize	7G							
<i>Übermass</i> Oversize	+ 0.10 mm + 0.20 mm							
<i>Feintoleranz</i> Fine tolerance	ISO 1 4H	50				56		58
<i>LH Linksgewinde</i> LH Left hand thread	ISO 2 6H							
		Z470VS-3	Z473VS-3	H420-4 H420TC-4	H450-3 H450TC-3	S420VS-4	S460VS-3	SA420-4
<i>DIN lang</i> DIN long	DIN 376	51	51	53	55	56	57	59
<i>Extra-lang</i> Extra-long	DC							
<i>ISO kurz</i> ISO short	ISO 529							
<i>DIN kurz</i> DIN short	DIN 352							
<i>DIN lang</i> DIN long	~DIN 2174							
<i>Toleranz</i> Tolerance	ISO 2 6H	51	51	53	55	56	57	59
<i>Übermass</i> Oversize	ISO 3 6G				55			
<i>Übermass</i> Oversize	7G							
<i>Übermass</i> Oversize	+ 0.10 mm + 0.20 mm							
<i>Feintoleranz</i> Fine tolerance	ISO 1 4H							59
<i>LH Linksgewinde</i> LH Left hand thread	ISO 2 6H							



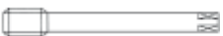
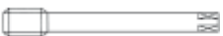







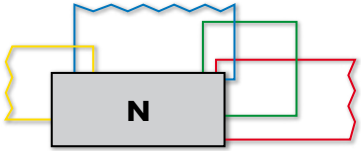





SA		TL		GG			K		
 R15	 R10			 R15	NV	 R15	 R15	 TiCN	 VS
									
									
SA350-3	SA390-3	TL320VS-4	TL351VS-3	GG350NV-3 GG550NV-3		GG350TC-3	GG353TC-3	K313TC-3	
58	57	58	58	60 60		60	60	66	
58	57	58	58	60		60	60	66	
58	57	58	58						
SA450-3		TL420VS-4	TL451VS-3	GG450NV-3 GG650NV-3		GG450TC-3	GG453TC-3	K413TC-3 K613TC-3	K613VS-3
59		59	59	61 61		61	61	66 67	67
59		59	59	61		61	61	66/67	67
59		59	59						



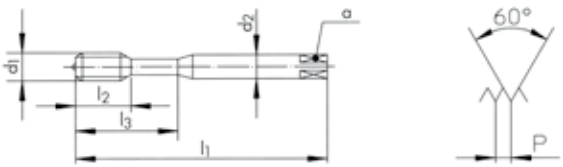







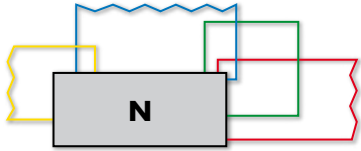

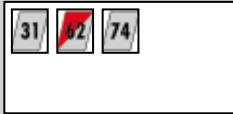
		RTS						
Merkmale Characteristics							 VS	 VS
		VS	VS	VS	VS	 VS		
								
Lochart Hole type								
		RTS320VS-4	RTS323VS-4	RTS360VS-3 RTS362VS-3	RTS365VS-3	RTS362VS-5 RTS365VS-5	RTS523VS-4	RTS565VS-3
<i>DIN lang</i> DIN long	DIN 371	62	62	63	63	64		
<i>Extra-lang</i> Extra-long	DC						65	65
<i>ISO kurz</i> ISO short	ISO 529							
<i>DIN kurz</i> DIN short	DIN 352							
<i>DIN lang</i> DIN long	~DIN 2174							
<i>Toleranz</i> Tolerance	ISO 2 6H	62	62	63	63	64	65	65
<i>Übermass</i> Oversize	ISO 3 6G			64				
<i>Übermass</i> Oversize	7G							
<i>Übermass</i> Oversize	+ 0.10 mm + 0.20 mm							
<i>Feintoleranz</i> Fine tolerance	ISO 1 4H							
<i>LH Linksgewinde</i> LH Left hand thread	ISO 2 6H							
		RTS420VS-4	RTS423VS-4	RTS462VS-3	RTS465VS-3		RTS623VS-4	RTS665VS-3
<i>DIN lang</i> DIN long	DIN 376	62	62	63	63			
<i>Extra-lang</i> Extra-long	DC						65	65
<i>ISO kurz</i> ISO short	ISO 529							
<i>DIN kurz</i> DIN short	DIN 352							
<i>DIN lang</i> DIN long	~DIN 2174							
<i>Toleranz</i> Tolerance	ISO 2 6H	62	62	63	63		65	65
<i>Übermass</i> Oversize	ISO 3 6G							
<i>Übermass</i> Oversize	7G							
<i>Übermass</i> Oversize	+ 0.10 mm + 0.20 mm							
<i>Feintoleranz</i> Fine tolerance	ISO 1 4H							
<i>LH Linksgewinde</i> LH Left hand thread	ISO 2 6H							

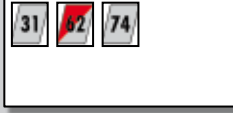
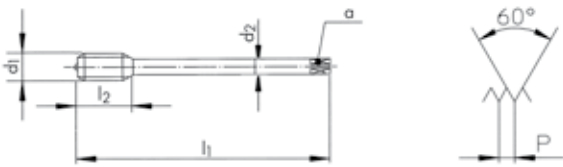







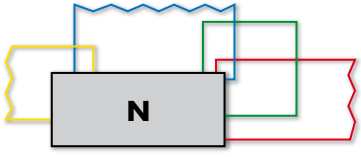

Inhaltsverzeichnis - Maschinengewindeformer DIN 13
Directory - Machine thread formers DIN 13





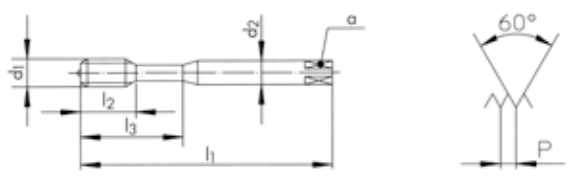
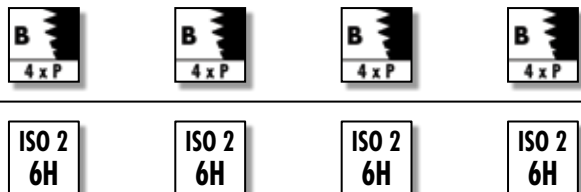

FS		FPS					FAS					
	VS		DL					VS				VS
					VS	VS			VS	VS		
	NEW						NEW				NEW	
FS380VS-5 FS380VS-3	FS380DL-5 FS380DL-3	FPS380CN-3 FPS381CN-3	FPS380VS-3 FPS381VS-3	FPS384VS-3	FPS581VS-3 FPS584VS-3	FAS380VS-3 FAS381VS-3	FAS384VS-3	FAS581VS-3 FAS584VS-3				
					71/72			75				
68	69	70	70	72		73	74					
68	69	70	70	72	71/72	73	74	75				
68	69		70									
			FPS481VS-3	FPS484VS-3	FPS681VS-3 FPS684VS-3	FAS481VS-3	FAS484VS-3	FAS681VS-3 FAS684VS-3				
					71/72			75				
			71	72		73	74					
			71	72	71/72	73	74	75				

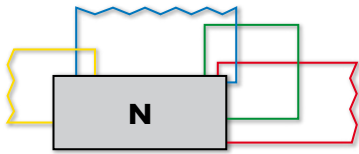
										N310-3	N310-3 LH	N320-3	
													
N310-3													
N310-3 LH	 LH												
N320-3													
													
Ø d ₁ M	P mm	l₁ mm	l₂ mm	l₃ mm	d₂ mm	a mm				ID	ID	ID	
1	0.25	40	5.5		2.5	2.1	3	0.75		150167			
1.1	0.25	40	5.5		2.5	2.1	3	0.85		174745			
1.2	0.25	40	5.5		2.5	2.1	3	0.95		150168			
1.4	0.30	40	7.0		2.5	2.1	3	1.10		150169			
1.5	0.30	40	7.0		2.5	2.1	3	1.20		174752			
1.6	0.35	40	8.0		2.5	2.1	3	1.25		174753			
1.7	0.35	40	8.0		2.5	2.1	3	1.35		174754			
1.8	0.35	40	8.0		2.5	2.1	3	1.45		174755			
2	0.40	45	8.0		2.8	2.1	3	1.60		101439	111460		
2.2	0.45	45	9.0		2.8	2.1	3	1.75		174756			
2.3	0.40	45	9.0		2.8	2.1	3	1.90		174757			
2.5	0.45	50	10.0		2.8	2.1	*3	2.05		101440	111461	* 101461	
2.6	0.45	50	10.0		2.8	2.1	3	2.15		101441			
3	0.50	56	12.0	18	3.5	2.7	*3	2.50		101442	111462	* 101462	
3.5	0.60	56	13.0	20	4.0	3.0	*3	2.90		101443		* 101463	
4	0.70	63	14.0	21	4.5	3.4	*3	3.30		101444	111464	* 101464	
5	0.80	70	15.0	25	6.0	4.9	*3	4.20		101445	111465	* 101465	
6	1.00	80	17.0	30	6.0	4.9	*3	5.00		101446	111466	* 101466	
8	1.25	90	20.0	35	8.0	6.2	3	6.80		101447			
10	1.50	100	22.0	39	10.0	8.0	3	8.50		101438			
<p>* N320-3 =  2</p>										<p>≤ M1.5 </p>			

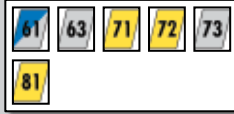

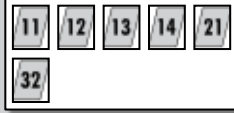

								N410-3	N410-3 LH		
											
N410-3											
N410-3 LH	 LH										
											
											
											
$\varnothing d_1$ M	P mm	l_1 mm	l_2 mm	d_2 mm	α mm			ID	ID		
3	0.50	56	12.0	2.2	1.8	3	2.50	101897			
4	0.70	63	14.0	2.8	2.1	3	3.30	101924			
5	0.80	70	15.0	3.5	2.7	3	4.20	101942			
6	1.00	80	17.0	4.5	3.4	3	5.00	101953			
7	1.00	80	17.0	5.5	4.3	3	6.00	142645	111491		
8	1.25	90	20.0	6.0	4.9	3	6.80	101958	111492		
10	1.50	100	22.0	7.0	5.5	3	8.50	101866	111478		
12	1.75	110	24.0	9.0	7.0	3	10.20	101870	111479		
14	2.00	110	28.0	11.0	9.0	3	12.00	101874	111480		
16	2.00	110	30.0	12.0	9.0	3	14.00	101880	111481		
18	2.50	125	33.0	14.0	11.0	3	15.50	101883	111482		
20	2.50	140	36.0	16.0	12.0	3	17.50	101885	125530		
22	2.50	140	36.0	18.0	14.5	3	19.50	101888			
24	3.00	160	39.0	18.0	14.5	4	21.00	101891	111485		
27	3.00	160	42.0	20.0	16.0	4	24.00	101895	111486		
30	3.50	180	45.0	22.0	18.0	4	26.50	101901	111487		
33	3.50	180	48.0	25.0	20.0	4	29.50	101907			
36	4.00	200	51.0	28.0	22.0	4	32.00	101915	111488		
39	4.00	200	55.0	32.0	24.0	4	35.00	101922			
42	4.50	200	55.0	32.0	24.0	4	37.50	101932			
48	5.00	250	63.0	36.0	29.0	4	43.00	111489			
56	5.50	280	71.0	45.0	35.0	5	50.50	111447			

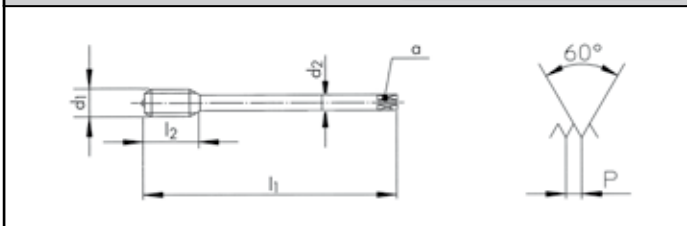
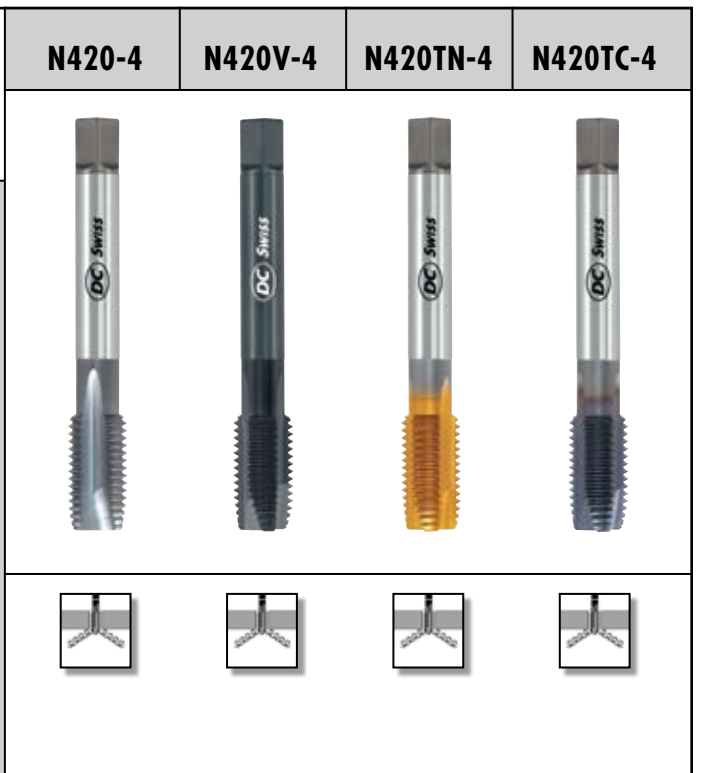

									N320-4	N320V-4	N320TN-4	N320TC-4	
													
N320-4													
N320V-4		V											
N320TN-4		TiN											
N320TC-4		TiCN											
													
Ø d ₁	P	l ₁	l ₂	l ₃	d ₂	a			ID	ID	ID	ID	
M	mm	mm	mm	mm	mm	mm							
*1	0.25	40	5.5		2.5	2.1	2	0.75	111467				
*1.1	0.25	40	5.5		2.5	2.1	2	0.85	111468				
*1.2	0.25	40	5.5		2.5	2.1	2	0.95	111469				
*1.4	0.30	40	7.0		2.5	2.1	2	1.10	111470				
*1.5	0.30	40	7.0		2.5	2.1	2	1.20	111471				
*1.6	0.35	40	8.0		2.5	2.1	2	1.25	101454				
*1.7	0.35	40	8.0		2.5	2.1	2	1.35	101455				
*1.8	0.35	40	8.0		2.5	2.1	2	1.45	101456				
*2	0.40	45	8.0		2.8	2.1	2	1.60	101458	101536	101528	152900	
*2.2	0.45	45	9.0		2.8	2.1	2	1.75	101459				
*2.3	0.40	45	9.0		2.8	2.1	2	1.90	101460				
2.5	0.45	50	10.0		2.8	2.1	3	2.05	101483	101545	101530	101522	
2.6	0.45	50	10.0		2.8	2.1	3	2.15	101484				
3	0.50	56	12.0	18	3.5	2.7	3	2.50	101485	101546	101531	101523	
3.5	0.60	56	13.0	20	4.0	3.0	3	2.90	101491	101547			
4	0.70	63	14.0	21	4.5	3.4	3	3.30	101495	101548	101532	101524	
5	0.80	70	15.0	25	6.0	4.9	3	4.20	101499	101549	101533	101525	
6	1.00	80	17.0	30	6.0	4.9	3	5.00	101503	101550	101534	101526	
8	1.25	90	20.0	35	8.0	6.2	3	6.80	101506	101551	101535	101527	
10	1.50	100	22.0	39	10.0	8.0	3	8.50	101481	101544	101529	101521	
<p>* N320-3 / N320V-3 N320TN-3 / N320TC-3</p> 									<p>≤ M1.5</p> 				











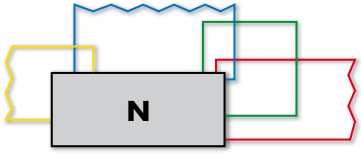

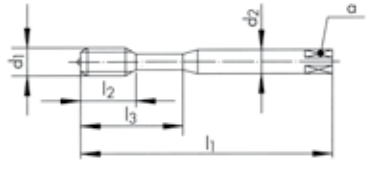

N420-4		
N420V-4	 V	
N420TN-4	 TiN	
N420TC-4	 TiCN	

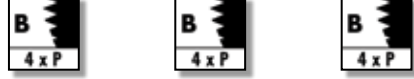
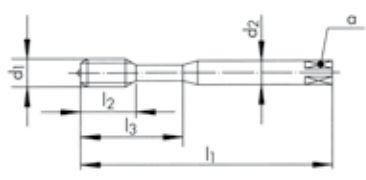









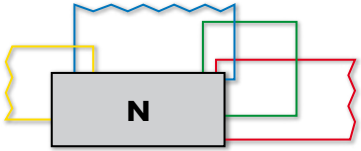

			
ISO 2 6H	ISO 2 6H	ISO 2 6H	ISO 2 6H

Ø d ₁ M	P mm	l ₁ mm	l ₂ mm	d ₂ mm	α mm			ID	ID	ID	ID
3	0.50	56	12.0	2.2	1.8	3	2.50	102119	143418		
4	0.70	63	14.0	2.8	2.1	3	3.30	102146	102279		
5	0.80	70	15.0	3.5	2.7	3	4.20	102171	102280	146297	
6	1.00	80	17.0	4.5	3.4	3	5.00	102182	102282	147439	
7	1.00	80	17.0	5.5	4.3	3	6.00	102189	144713		
8	1.25	90	20.0	6.0	4.9	3	6.80	102195	102285	102251	102233
9	1.25	90	20.0	7.0	5.5	3	7.80	102202			
10	1.50	100	22.0	7.0	5.5	3	8.50	102061	102263	102240	102228
11	1.50	100	19.0	8.0	6.2	3	9.50	162770			
12	1.75	110	24.0	9.0	7.0	3	10.20	102072	102265	102243	102229
14	2.00	110	28.0	11.0	9.0	3	12.00	102081	102267	102245	
16	2.00	110	30.0	12.0	9.0	3	14.00	102090	102269	102247	102231
18	2.50	125	33.0	14.0	11.0	3	15.50	102097	102271		
20	2.50	140	36.0	16.0	12.0	3	17.50	102101	102273	102248	102232
22	2.50	140	36.0	18.0	14.5	3	19.50	102106	102275		
24	3.00	160	39.0	18.0	14.5	4	21.00	102110	102278	144220	163736
27	3.00	160	42.0	20.0	16.0	4	24.00	102117	143856		
30	3.50	180	45.0	22.0	18.0	4	26.50	102124	105124		
33	3.50	180	48.0	25.0	20.0	4	29.50	102130	146968		
36	4.00	200	51.0	28.0	22.0	4	32.00	102137	143430		
39	4.00	200	55.0	32.0	24.0	4	35.00	102144	158724		
42	4.50	200	55.0	32.0	24.0	4	37.50	102158	143107		
45	4.50	220	59.0	36.0	29.0	4	40.50	* 110225			
48	5.00	250	63.0	36.0	29.0	4	43.00	110226	157517		
56	5.50	280	71.0	45.0	35.0	5	50.50	110229	158178		

										N320-4	N320-4 LH	N320V-4 LH	
													
N320-4													
N320-4 LH		LH											
N320V-4 LH		V	LH										
													
										ISO 1 4H	ISO 2 6H	ISO 2 6H	
Ø d ₁	P	l ₁	l ₂	l ₃	d ₂	a				ID	ID	ID	
M	mm	mm	mm	mm	mm	mm							
*2	0.40	45	8.0		2.8	2.1	2	1.60		162503	111472	162771	
2.5	0.45	50	10.0		2.8	2.1	3	2.05		159345			
3	0.50	56	12.0	18	3.5	2.7	3	2.50		101487	111473	162772	
4	0.70	63	14.0	21	4.5	3.4	3	3.30		101493	111474	162773	
5	0.80	70	15.0	25	6.0	4.9	3	4.20		101497	111475	162774	
6	1.00	80	17.0	30	6.0	4.9	3	5.00		101501	111476	162775	
8	1.25	90	20.0	35	8.0	6.2	3	6.80	Δ	* 146482			
10	1.50	100	22.0	39	10.0	8.0	3	8.50		* 146484			
<p>* N320-3 </p> <p>Δ ISO 1 4H =  6.70</p>													

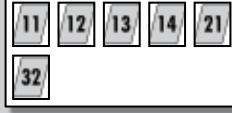
									N420-4	N420-4 LH	N420V-4 LH	
N420-4												
N420-4 LH	LH											
N420V-4 LH	V LH											
$\varnothing d_1$	P	l_1	l_2	d_2	α				ISO 1 4H	ISO 2 6H	ISO 2 6H	
M	mm	mm	mm	mm	mm				ID	ID	ID	
8	1.25	90	20.0	6.0	4.9	3	Δ 6.80		102193	102198	142621	
10	1.50	100	22.0	7.0	5.5	3	8.50		102059	102064	143287	
12	1.75	110	24.0	9.0	7.0	3	10.20		102070	102040	146583	
14	2.00	110	28.0	11.0	9.0	3	12.00			102084	146563	
16	2.00	110	30.0	12.0	9.0	3	14.00			102093	143108	
20	2.50	140	36.0	16.0	12.0	3	17.50			102103	145579	
24	3.00	160	39.0	18.0	14.5	4	21.00			111493	145578	
30	3.50	180	45.0	22.0	18.0	4	26.50			* 111494		

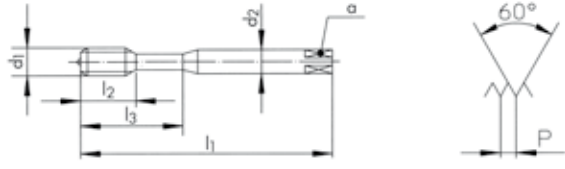









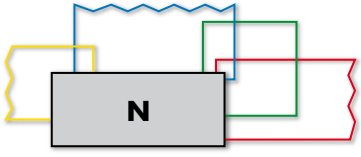



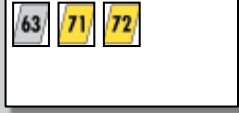

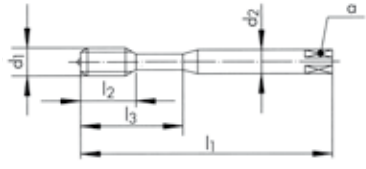
Δ ISO 1 4H = 6.70

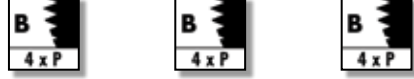
									N320-4	N320V-4	N320-4	N320-4			
															
N320-4															
N320V-4	 V														
															
Ø d ₁ M	P mm	l ₁ mm	l ₂ mm	l ₃ mm	d ₂ mm	a mm		6H → ←	ID	6H + mm	ID	6H + mm	ID	6H + mm	ID
*2	0.40	45	8.0		2.8	2.1	2	1.60	101457	0.019	143584	0.019			
2.5	0.45	50	10.0		2.8	2.1	3	2.05	101482	0.020	150522	0.020			
3	0.50	56	12.0	18	3.5	2.7	3	2.50	101486	0.020	143116	0.020	101489	0.036	101488
3.5	0.60	56	13.0	20	4.0	3.0	3	2.95	101490	0.021					
4	0.70	63	14.0	21	4.5	3.4	3	3.35	101494	0.022	143087	0.022	101496	0.041	111522
5	0.80	70	15.0	25	6.0	4.9	3	4.25	101498	0.024	143088	0.024	101500	0.044	111523
6	1.00	80	17.0	30	6.0	4.9	3	5.00	101502	0.026	143089	0.026	101504	0.050	111524
8	1.25	90	20.0	35	8.0	6.2	3	6.80	101505	0.028	143604	0.028			











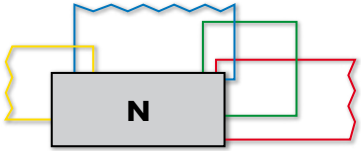







* N320-3 / N320V-3

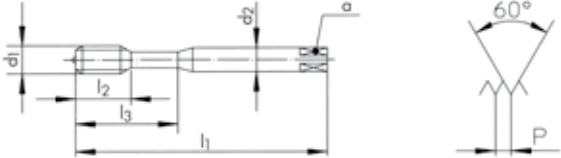











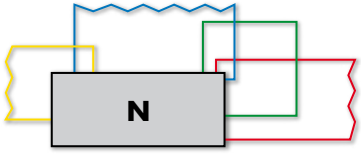





									N420-4	N420V-4	N420-4	N420-4										
N420-4		<table border="1"> <tr> <td>61</td> <td>63</td> <td>71</td> <td>72</td> <td>73</td> </tr> <tr> <td>81</td> <td colspan="4"></td> </tr> </table>							61	63	71	72	73	81								
61	63	71	72	73																		
81																						
N420V-4	V	<table border="1"> <tr> <td>11</td> <td>12</td> <td>13</td> <td>14</td> <td>21</td> </tr> <tr> <td>32</td> <td colspan="4"></td> </tr> </table>							11	12	13	14	21	32								
11	12	13	14	21																		
32																						
									<table border="1"> <tr> <td></td> <td></td> <td></td> <td></td> </tr> <tr> <td></td> <td></td> <td></td> <td></td> </tr> </table>													
$\varnothing d_1$	P	l_1	l_2	d_2	α				ID	$6H$	ID	$6H$	ID	$6H$	ID							
M	mm	mm	mm	mm	mm		$\rightarrow \leftarrow$			+ mm		+ mm		+ mm								
8	1.25	90	20.0	6.0	4.9	3	6.80		102194	0.028	145246	0.028	102199	0.052	102196							
10	1.50	100	22.0	7.0	5.5	3	8.50		102060	0.032	143726	0.032	102065	0.060	102062							
12	1.75	110	24.0	9.0	7.0	3	10.30		102071	0.034	145655	0.034	102076	0.066	102073							
16	2.00	110	30.0	12.0	9.0	3	14.00		135531	0.038	162795	0.038	102094	0.072	102091							

									N321-4	N330-4	N330V-4	
												
N321-4												
N330-4												
N330V-4												
 												
												
Ø d ₁ M	P mm	l ₁ mm	l ₂ mm	l ₃ mm	d ₂ mm	a mm			ID	ID	ID	
*1	0.25	40	5.5		2.5	2.1	2	0.75		101558		
*1.1	0.25	40	5.5		2.5	2.1	2	0.85		* 101559		
*1.2	0.25	40	5.5		2.5	2.1	2	0.95		101560		
*1.4	0.30	40	7.0		2.5	2.1	2	1.10		101561		
*1.6	0.35	40	8.0		2.5	2.1	2	1.25		101562	151246	
*1.7	0.35	40	8.0		2.5	2.1	2	1.35		* 101563		
*2	0.40	45	8.0		2.8	2.1	2	1.60	101552	105125	101572	
*2.2	0.45	45	9.0		2.8	2.1	2	1.75		* 105126		
*2.3	0.40	45	9.0		2.8	2.1	2	1.90		* 105127		
2.5	0.45	50	10.0		2.8	2.1	*3	2.05	101553	101565	101573	
2.6	0.45	50	10.0		2.8	2.1	2	2.15		* 101566		
3	0.50	56	12.0	18	3.5	2.7	*3	2.50	101555	101567	101574	
3.5	0.60	56	13.0	20	4.0	3.0	2	2.90		101568		
4	0.70	63	14.0	21	4.5	3.4	3	3.30	101557	101569	101576	
5	0.80	70	15.0	25	6.0	4.9	3	4.20		101570	101577	
6	1.00	80	17.0	30	6.0	4.9	3	5.00		101571	101578	
<p>* N321-3 / N330-3 / N330V-3  * N330-4 =  2</p> <p>* N330V-4 =  2</p>									<p>≤ M1.5 </p>			

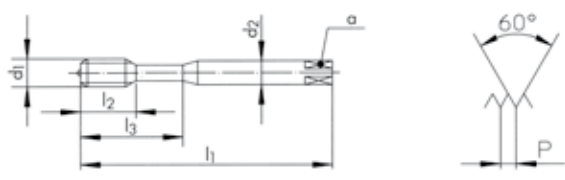

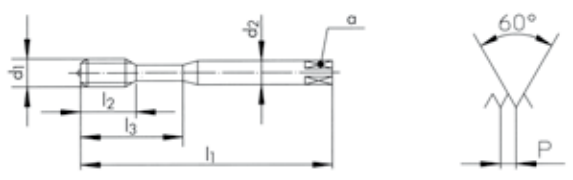





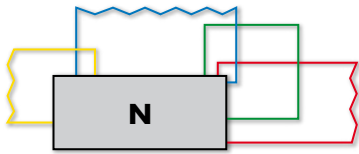





























									N420-4	N421-4	N430-4	N430V-4
N420-4												
N421-4												
N430-4												
N430V-4												
$\varnothing d_1$	P	l_1	l_2	d_2	α			6H	ID	ID	ID	ID
M	mm	mm	mm	mm	mm			$\rightarrow \leftarrow$				
4	0.70	63	14.0	2.8	2.1	3		3.30		102293		
5	0.80	70	15.0	3.5	2.7	3		4.20		102294		
6	1.00	80	17.0	4.5	3.4	3		5.00		102295		
8	1.25	90	20.0	6.0	4.9	3		6.80	102197	102296	102301	102306
10	1.50	100	22.0	7.0	5.5	3		8.50	102063	102286	102297	102302
12	1.75	110	24.0	9.0	7.0	3		10.20	102074	102287	102298	102303
14	2.00	110	28.0	11.0	9.0	3		12.00		* 102288		
16	2.00	110	30.0	12.0	9.0	3		14.00	102092	102289		

									N350-3	N350V-3		
												
N350-3									 			
N350V-3	 								 			
 									 			
									 			
Ø d ₁ M	P mm	l ₁ mm	l ₂ mm	l ₃ mm	d ₂ mm	a mm			ID	ID		
2	0.40	45	8.0		2.8	2.1	2	1.60	101580	101593		
2.3	0.40	45	9.0		2.8	2.1	2	1.90	101581			
2.5	0.45	50	10.0		2.8	2.1	2	2.05	101582	101594		
2.6	0.45	50	10.0		2.8	2.1	2	2.15	101583			
3	0.50	56	12.0	18	3.5	2.7	2	2.50	101584	101595		
3.5	0.60	56	13.0	20	4.0	3.0	2	2.90	101585			
4	0.70	63	14.0	21	4.5	3.4	2	3.30	101587	101596		
5	0.80	70	15.0	25	6.0	4.9	3	4.20	101589	101597		
6	1.00	80	17.0	30	6.0	4.9	3	5.00	101591	101598		
8	1.25	90	20.0	35	8.0	6.2	3	6.80	101592	146810		
10	1.50	100	22.0	39	10.0	8.0	3	8.50	101579	147217		

									N450-3	N450V-3		
<p>N450-3 </p> <p>N450V-3 </p>												
$\varnothing d_1$ M	P mm	l_1 mm	l_2 mm	d_2 mm	α mm				ID	ID		
8	1.25	90	20.0	6.0	4.9	3		6.80	102327	102334		
10	1.50	100	22.0	7.0	5.5	3		8.50	102314	102329		
12	1.75	110	24.0	9.0	7.0	3		10.20	102317	102330		
14	2.00	110	28.0	11.0	9.0	3		12.00	102319	145487		
16	2.00	110	30.0	12.0	9.0	3		14.00	102321	102331		
20	2.50	140	36.0	16.0	12.0	4		17.50	102324	102332		
24	3.00	160	39.0	18.0	14.5	4		21.00	102325	102333		





									N360-3	N360V-3	N360TN-3	N360TC-3
												
N360-3												
N360V-3	 V											
N360TN-3	 TiN											
N360TC-3	 TiCN											
												
												
Ø d ₁ M	P mm	l ₁ mm	l ₂ mm	l ₃ mm	d ₂ mm	a mm			ID	ID	ID	ID
2	0.40	45	7.0		2.8	2.1	2	1.60	101618	101708	101697	146842
2.2	0.45	45	8.0		2.8	2.1	2	1.75	101619			
2.3	0.40	45	8.0		2.8	2.1	2	1.90	101620			
2.5	0.45	50	9.0		2.8	2.1	2	2.05	101622	101709	101698	101689
2.6	0.45	50	9.0		2.8	2.1	2	2.15	101623	101710		
3	0.50	56	5.5	18	3.5	2.7	3	2.50	101626	101711	101699	101690
3.5	0.60	56	6.5	20	4.0	3.0	3	2.90	101630	142625		
4	0.70	63	7.5	21	4.5	3.4	3	3.30	101635	101713	101700	101691
4.5	0.75	70	9.0	25	6.0	4.9	3	3.75	101639			
5	0.80	70	9.0	25	6.0	4.9	3	4.20	101644	101715	101701	101692
6	1.00	80	11.0	30	6.0	4.9	3	5.00	101652	101717	101703	101693
7	1.00	80	11.0	30	7.0	5.5	3	6.00	101656	101718		
8	1.25	90	12.5	35	8.0	6.2	3	6.80	101663	101721	101705	101694
9	1.25	90	12.5	35	9.0	7.0	3	7.80	101668			
10	1.50	100	14.0	39	10.0	8.0	3	8.50	101612	101707	101696	101688







N460-3		     
N460V-3	 	     
N460TN-3	 	        
N460TC-3	 	          

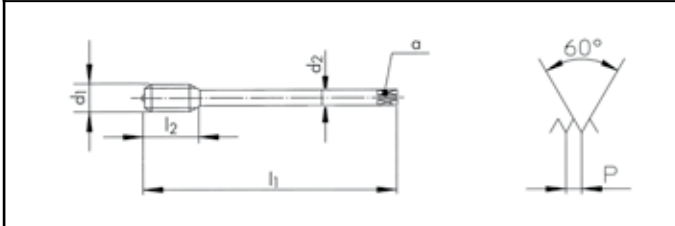

N460-3	N460V-3	N460TN-3	N460TC-3
--------	---------	----------	----------











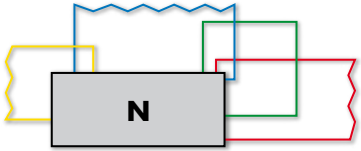

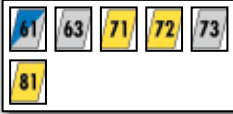

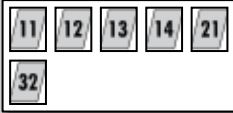



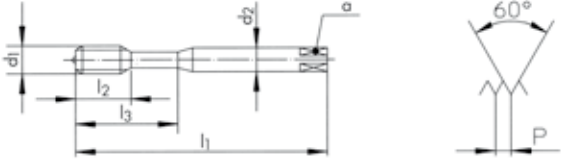





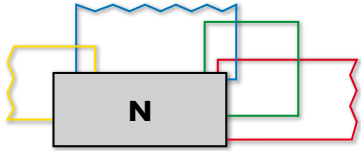















 < 2.5 x D	 < 2.5 x D	 < 2.5 x D	 < 2.5 x D
--	---	--	--











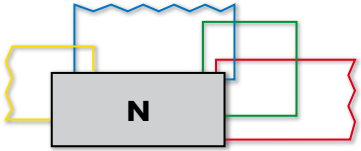

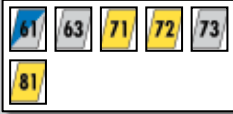

 2.5 x P	 2.5 x P	 2.5 x P	 2.5 x P
ISO 2 6H	ISO 2 6H	ISO 2 6H	ISO 2 6H

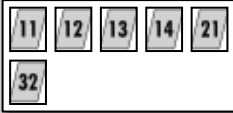
Ø d ₁ M	P mm	l ₁ mm	l ₂ mm	d ₂ mm	α mm			ID	ID	ID	ID
5	0.80	70	9.0	3.5	2.7	3	4.20	102410	102489	160682	
6	1.00	80	11.0	4.5	3.4	3	5.00	102411	102491	152850	
8	1.25	90	12.5	6.0	4.9	3	6.80	102412	102492	152849	
10	1.50	100	14.0	7.0	5.5	3	8.50	102351	102461	150242	158687
12	1.75	110	14.0	9.0	7.0	3	10.20	102359	102465	102449	102438
14	2.00	110	14.0	11.0	9.0	3	12.00	102369	102468	102451	111615
16	2.00	110	18.0	12.0	9.0	3	14.00	102376	102471	102453	102440
18	2.50	125	21.0	14.0	11.0	3	15.50	102383	102473		
20	2.50	140	24.0	16.0	12.0	4	17.50	102389	102475	102454	143280
22	2.50	140	24.0	18.0	14.5	4	19.50	102394	102477		
24	3.00	160	27.0	18.0	14.5	4	21.00	102398	102480	143119	150018
27	3.00	160	27.0	20.0	16.0	4	24.00	175423	102481		
30	3.50	180	30.0	22.0	18.0	4	26.50	150246	102482		
33	3.50	180	33.0	25.0	20.0	4	29.50	167621	102483		
36	4.00	200	36.0	28.0	22.0	5	32.00	143914	102484		
39	4.00	200	40.0	32.0	24.0	5	35.00	175424	102485		
42	4.50	200	40.0	32.0	24.0	5	37.50	169122	102486		
45	4.50	220	44.0	36.0	29.0	5	40.50		102487		
48	5.00	250	48.0	36.0	29.0	5	43.00		102488		
52	5.00	250	52.0	40.0	32.0	5	47.00		110228		
56	5.50	280	56.0	45.0	35.0	6	50.50		102490		
64	6.00	315	64.0	50.0	39.0	6	58.00		143805		

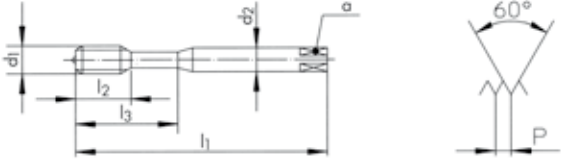
									N360-3 LH	N360V-3 LH	N360-3	N360V-3
												
N360-3 LH		LH										
N360V-3 LH		V LH										
N360-3												
N360V-3		V										
												
												
Ø d ₁ M	P mm	l ₁ mm	l ₂ mm	l ₃ mm	d ₂ mm	a mm		6H → ←	ID	ID	ID 6H + mm	ID 6H + mm
2	0.40	45	7.0		2.8	2.1	2	1.60			101617 0.019	146000 0.019
2.5	0.45	50	9.0		2.8	2.1	2	2.05			101621 0.020	143294 0.020
3	0.50	56	5.5	18	3.5	2.7	3	2.50	101627	146811	101625 0.020	104816 0.020
3.5	0.60	56	6.5	20	4.0	3.0	3	2.95			101629 0.021	125829 0.021
4	0.70	63	7.5	21	4.5	3.4	3	3.30	101637	162540	101634 0.022	104817 0.022
5	0.80	70	9.0	25	6.0	4.9	3	4.20	101646	144003	101643 0.024	104818 0.024
6	1.00	80	11.0	30	6.0	4.9	3	5.00	101654	144004	101669 0.026	104819 0.026
8	1.25	90	12.5	35	8.0	6.2	3	6.80	101666	143925	101662 0.028	104820 0.028
10	1.50	100	14.0	39	10.0	8.0	3	8.50	101615	143587	101611 0.032	104821 0.032

								N460-3 LH	N460V-3 LH	N460-3	N460V-3		
								<p>N460-3 LH  LH </p> <p>N460V-3 LH  V LH </p> <p>N460-3  </p> <p>N460V-3  V </p>					
													
													
													
$\varnothing d_1$ M	P mm	l_1 mm	l_2 mm	d_2 mm	α mm		$6H$ $\rightarrow \leftarrow$	ID	ID	ID	$6H$ + mm	ID	$6H$ + mm
12	1.75	110	14.0	9.0	7.0	3	10.20	102362	146354	102358	0.034	143602	0.034
14	2.00	110	14.0	11.0	9.0	3	12.00			102368	0.038	144712	0.038
16	2.00	110	18.0	12.0	9.0	3	14.00	102378	143439	102375	0.038	150197	0.038
20	2.50	140	24.0	16.0	12.0	4	17.50	102390	146564	102388	0.042	145420	0.042

									N360-3	N360-3	N360V-3	N360-3		
														
<p>N360-3</p>  														
<p>N360V-3</p>   														
														
Ø d ₁ M	P mm	l ₁ mm	l ₂ mm	l ₃ mm	d ₂ mm	a mm			ID	ID	6H + mm	ID	6H + mm	ID
3	0.50	56	5.5	18	3.5	2.7	3	2.50	101624	101628	0.036	144311	0.036	160847
4	0.70	63	7.5	21	4.5	3.4	3	3.30	101633	101638	0.041	144192	0.041	101636
5	0.80	70	9.0	25	6.0	4.9	3	4.20	101642	101647	0.044	143208	0.044	101645
6	1.00	80	11.0	30	6.0	4.9	3	5.00	101651	101655	0.050	146709	0.050	101653
8	1.25	90	12.5	35	8.0	6.2	3	△ 6.80	101661	101667	0.052	146267	0.052	101664
10	1.50	100	14.0	39	10.0	8.0	3	8.50	101610	101616	0.060	142547	0.060	101613

△ ISO 1 4H =  6.70

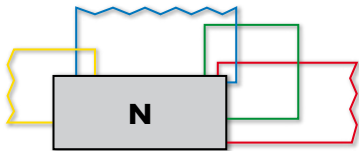

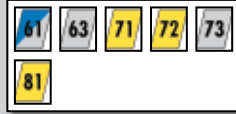

N460-3 N460-3 N460V-3 N460-3

N460-3



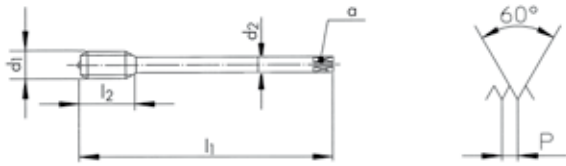
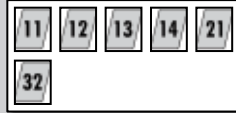







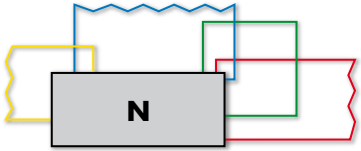

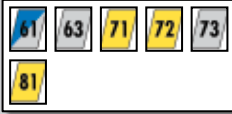

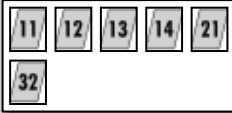



N460V-3

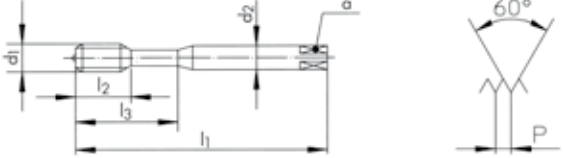

∅ d ₁ M	P mm	l ₁ mm	l ₂ mm	d ₂ mm	a mm		
12	1.75	110	14.0	9.0	7.0	3	10.20
16	2.00	110	18.0	12.0	9.0	3	14.00

ID	ID	6H + mm	ID	6H + mm	ID
* 124987	102363	0.066	142532	0.066	102360
	102379	0.072	144956	0.072	102377

									N360-5	N360V-5	N361-3	N362V-3
												
N360-5												
N360V-5	 											
N361-3	 											
N362V-3	  											
												
												
Ø d ₁ M	P mm	l ₁ mm	l ₂ mm	l ₃ mm	d ₂ mm	a mm			ID	ID	ID	ID
2	0.40	45	7.0		2.8	2.1	2	1.60	158079	150058		
3	0.50	56	5.5	18	3.5	2.7	3	2.50	104809	142646	101735	
4	0.70	63	7.5	21	4.5	3.4	3	3.30	104810	142647	101736	101741
5	0.80	70	9.0	25	6.0	4.9	3	4.20	104811	142648	101737	101742
6	1.00	80	11.0	30	6.0	4.9	3	5.00	104812	142649	101738	101743
8	1.25	90	12.5	35	8.0	6.2	3	6.80	104813	142650	101739	101744
10	1.50	100	14.0	39	10.0	8.0	3	8.50	104814	124899	101734	101740

								N460-5	N460V-5	N461-3	N462V-3
N460-5											
N460V-5											
N461-3											
N462V-3											
$\varnothing d_1$	P	l_1	l_2	d_2	α			ID	ID	ID	ID
M	mm	mm	mm	mm	mm						
12	1.75	110	14.0	9.0	7.0	3	10.20	104815	142651	102506	102512
14	2.00	110	14.0	11.0	9.0	3	12.00			* 102507	102513
16	2.00	110	18.0	12.0	9.0	3	14.00			* 102508	102514
18	2.50	125	21.0	14.0	11.0	3	15.50			* 111614	102515
20	2.50	140	24.0	16.0	12.0	4	17.50				102516
24	3.00	160	27.0	18.0	14.5	4	21.00				102517
27	3.00	160	27.0	20.0	16.0	4	24.00				159244
30	3.50	180	30.0	22.0	18.0	4	26.50				143090



										N520-4	N520V-4	N520TN-4	
N520-4													
N520V-4	V												
N520TN-4	TiN												
Ø d ₁ M	P mm	l ₁ mm	l ₂ mm	l ₃ mm	d ₂ mm	a mm				ID	ID	ID	
2.5	0.45	100	10.0		2.8	2.1	3		2.05	102594	142623		
3	0.50	112	12.0	18	3.5	2.7	3		2.50	102595	143399	162790	
4	0.70	112	14.0	21	4.5	3.4	3		3.30	102596	143400	146837	
5	0.80	125	15.0	25	6.0	4.9	3		4.20	102597	142654	150113	
6	1.00	125	17.0	30	6.0	4.9	3		5.00	102598	143137	148821	

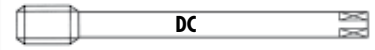

									N620-4	N620V-4	N620TN-4											
N620-4		<table border="1"> <tr> <td>61</td> <td>63</td> <td>71</td> <td>72</td> <td>73</td> </tr> <tr> <td>81</td> <td colspan="4"></td> </tr> </table>							61	63	71	72	73	81								
61	63	71	72	73																		
81																						
N620V-4	V	<table border="1"> <tr> <td>11</td> <td>12</td> <td>13</td> <td>14</td> <td>21</td> </tr> <tr> <td>32</td> <td colspan="4"></td> </tr> </table>							11	12	13	14	21	32								
11	12	13	14	21																		
32																						
N620TN-4	TiN	<table border="1"> <tr> <td>11</td> <td>12</td> <td>13</td> <td>14</td> <td>21</td> </tr> <tr> <td>31</td> <td>32</td> <td>73</td> <td>74</td> <td></td> </tr> </table>							11	12	13	14	21	31	32	73	74					
11	12	13	14	21																		
31	32	73	74																			
									<table border="1"> <tr> <td>B 4 x P</td> <td>B 4 x P</td> <td>B 4 x P</td> </tr> </table>			B 4 x P	B 4 x P	B 4 x P								
B 4 x P	B 4 x P	B 4 x P																				
									<table border="1"> <tr> <td>ISO 2 6H</td> <td>ISO 2 6H</td> <td>ISO 2 6H</td> </tr> </table>			ISO 2 6H	ISO 2 6H	ISO 2 6H								
ISO 2 6H	ISO 2 6H	ISO 2 6H																				
$\varnothing d_1$ M	P mm	l_1 mm	l_2 mm	d_2 mm	α mm				ID	ID	ID											
4	0.70	112	14.0	2.8	2.1	3	3.30		102619	142582	146442											
5	0.80	125	15.0	3.5	2.7	3	4.20		102620	142657	146443											
6	1.00	125	17.0	4.5	3.4	3	5.00		102621	142658	144591											
8	1.25	140	20.0	6.0	4.9	3	6.80		102622	143401	146262											
10	1.50	160	22.0	7.0	5.5	3	8.50		102614	142660	146849											
12	1.75	180	24.0	9.0	7.0	3	10.20		102615	143127	146295											
14	2.00	180	28.0	11.0	9.0	3	12.00		102616	151905												
16	2.00	200	30.0	12.0	9.0	3	14.00		102617	143106	143574											
20	2.50	224	36.0	16.0	12.0	3	17.50		102618	143596												



										N560-3	N560V-3	N560TN-3		
N560-3			61	63	71	72	73	81						
N560V-3		V	11	12	13	14	21	32						
N560TN-3		TiN	11	12	13	14	21	31	32	73	74			
										ISO 2 6H	ISO 2 6H	ISO 2 6H		
Ø d ₁ M	P mm	l₁ mm	l₂ mm	l₃ mm	d₂ mm	a mm			ID	ID	ID			
2.5	0.45	100	9.0		2.8	2.1	2	2.05	102600	102607				
3	0.50	112	5.5	18	3.5	2.7	3	2.50	102601	102608	142663			
4	0.70	112	7.5	21	4.5	3.4	3	3.30	102602	102609	142664			
5	0.80	125	9.0	25	6.0	4.9	3	4.20	102603	102610	142665			
6	1.00	125	11.0	30	6.0	4.9	3	5.00	102604	102611	142666			
8	1.25	140	12.5	35	8.0	6.2	3	6.80	102605	102612	142667			
10	1.50	160	14.0	39	10.0	8.0	3	8.50	102599	102606	142668			

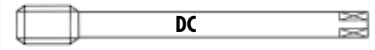











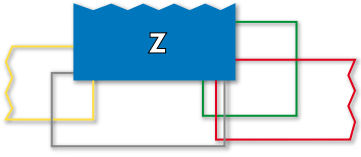











								N660-3	N660V-3	N660TN-3	
N660-3											
N660V-3											
N660TN-3											
$\varnothing d_1$ M	P mm	l_1 mm	l_2 mm	d_2 mm	α mm			ID	ID	ID	
6	1.00	125	11.0	4.5	3.4	3	5.00	162792	115657		
8	1.25	140	12.5	6.0	4.9	3	6.80	162793	115544		
10	1.50	160	14.0	7.0	5.5	3	8.50	162794	135539	173484	
12	1.75	180	14.0	9.0	7.0	3	10.20	102623	102626	142669	
14	2.00	180	14.0	11.0	9.0	3	12.00	162253	147500		
16	2.00	200	18.0	12.0	9.0	3	14.00	102624	102627	142670	
20	2.50	224	24.0	16.0	12.0	4	17.50	102625	102628		

									W320-4	W420-4	W320DL-4	W420DL-4	
W320-4		71 72 81											
W420-4		71 72 81											
W320DL-4		DL	71 72 81										
W420DL-4		DL	71 72 81										
$\varnothing d_1$ M	P mm	l_1 mm	l_2 mm	l_3 mm	d_2 mm	a mm			ID	ID	ID	ID	
*2	0.40	45	8.0		2.8	2.1	2	1.60	104612		176688		
2.5	0.45	50	10.0		2.8	2.1	2	2.05	104613		176689		
2.6	0.45	50	10.0		2.8	2.1	2	2.15	* 104614				
3	0.50	56	12.0	18	3.5	2.7	2	2.50	104615		176690		
3.5	0.60	56	13.0	20	4.0	3.0	2	2.90	* 104616				
4	0.70	63	14.0	21	4.5	3.4	2	3.30	104617		176691		
5	0.80	70	15.0	25	6.0	4.9	2	4.20	104618		176354		
6	1.00	80	17.0	30	6.0	4.9	2	5.00	104619		175590		
8	1.25	90	20.0		6.0	4.9	2	6.80		104636		176692	
10	1.50	100	22.0		7.0	5.5	2	8.50		104632		176693	
12	1.75	110	24.0		9.0	7.0	3	10.20		104633		176694	
16	2.00	110	30.0		12.0	9.0	3	14.00		104634		176695	

* W320-3
* W320DL-3

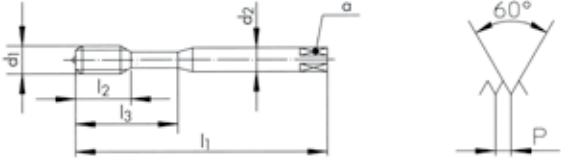

									W360-3	W460-3	W360DL-3	W460DL-3	
W360-3													
W460-3													
W360DL-3		DL								NEW			
W460DL-3		DL								NEW			
Ø d ₁ M	P mm	l ₁ mm	l ₂ mm	l ₃ mm	d ₂ mm	α mm			ID	ID	ID	ID	
2	0.40	45	7.0		2.8	2.1	2	1.60	104625		176719		
2.5	0.45	50	9.0		2.8	2.1	2	2.05	104626		176720		
3	0.50	56	5.5	18	3.5	2.7	2	2.50	104627		176721		
4	0.70	63	7.5	21	4.5	3.4	2	3.30	104628		176722		
5	0.80	70	9.0	25	6.0	4.9	2	4.20	104629		176723		
6	1.00	80	11.0	30	6.0	4.9	2	5.00	104630		176355		
8	1.25	90	12.5	35	8.0	6.2	2	6.80	104631		176724		
10	1.50	100	14.0	39	10.0	8.0	2	8.50	104624		176725		
12	1.75	110	14.0		9.0	7.0	3	10.20		104640		176726	
16	2.00	110	18.0		12.0	9.0	3	14.00		104641		176727	

									Z320V-4	Z420V-4	Z320VS-4	Z420VS-4
Z320V-4		V	21	22	23	41	42	51				
Z420V-4		V	21	22	23	41	42	51				
Z320VS-4		VS	21	22	23	24	51	61				
Z420VS-4		VS	21	22	23	24	51	61				
									B 4 x P	B 4 x P	B 4 x P	B 4 x P
									ISO 2 6H	ISO 2 6H	ISO 2 6H	ISO 2 6H
Ø d ₁ M	P mm	l ₁ mm	l ₂ mm	l ₃ mm	d ₂ mm	a mm			ID	ID	ID	ID
*1.6	0.35	40	8.0		2.5	2.1	2	1.25	142671			
*2	0.40	45	8.0		2.8	2.1	2	1.60	111613			
2.5	0.45	50	10.0		2.8	2.1	3	2.05	111455		143683	
2.6	0.45	50	10.0		2.8	2.1	3	2.15	142672			
3	0.50	56	12.0	18	3.5	2.7	3	2.50	104669		104830	
4	0.70	63	14.0	21	4.5	3.4	3	3.30	104670		104831	
5	0.80	70	15.0	25	6.0	4.9	3	4.20	104671		104832	
6	1.00	80	17.0	30	6.0	4.9	3	5.00	104672		104833	
8	1.25	90	20.0	35	8.0	6.2	3	6.80	104673		104834	
10	1.50	100	22.0	39	10.0	8.0	3	8.50	104668		104835	
12	1.75	110	24.0		9.0	7.0	3	10.20		104723		104836
14	2.00	110	28.0		11.0	9.0	3	12.00		142673		143684
16	2.00	110	30.0		12.0	9.0	3	14.00		105068		111569
18	2.50	125	33.0		14.0	11.0	4	15.50		142674		
20	2.50	140	36.0		16.0	12.0	4	17.50		105069		111570
22	2.50	140	36.0		18.0	14.5	4	19.50		146003		
24	3.00	160	39.0		18.0	14.5	4	21.00		142675		
30	3.50	180	45.0		22.0	18.0	4	26.50		142676		

* Z320V-3



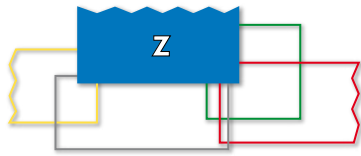

Z360V-3

Z362V-3

Z462V-3

Z360V-3



Z362V-3



Z462V-3

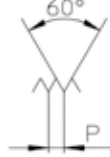
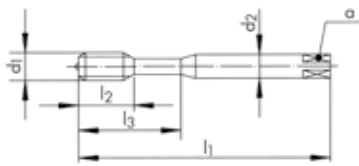

ISO 2
6H

ISO 2
6H

ISO 2
6H

Ø d ₁ M	P mm	l ₁ mm	l ₂ mm	l ₃ mm	d ₂ mm	a mm		
2	0.40	45	7.0		2.8	2.1	2	1.60
2.5	0.45	50	9.0		2.8	2.1	2	2.05
2.6	0.45	50	9.0		2.8	2.1	2	2.15
3	0.50	56	5.5	18	3.5	2.7	3	2.50
3.5	0.60	56	6.5	20	4.0	3.0	3	2.90
4	0.70	63	7.5	21	4.5	3.4	3	3.30
5	0.80	70	9.0	25	6.0	4.9	3	4.20
6	1.00	80	11.0	30	6.0	4.9	3	5.00
8	1.25	90	12.5	35	8.0	6.2	3	6.80
10	1.50	100	14.0	39	10.0	8.0	3	8.50
12	1.75	110	14.0		9.0	7.0	3	10.20
14	2.00	110	14.0		11.0	9.0	3	12.00
16	2.00	110	18.0		12.0	9.0	3	14.00
18	2.50	125	21.0		14.0	11.0	3	15.50
20	2.50	140	24.0		16.0	12.0	3	17.50
22	2.50	140	24.0		18.0	14.5	3	19.50
24	3.00	160	27.0		18.0	14.5	4	21.00
27	3.00	160	27.0		20.0	16.0	4	24.00
30	3.50	180	30.0		22.0	18.0	4	26.50
36	4.00	200	36.0		28.0	22.0	4	32.00
42	4.50	200	40.0		32.0	24.0	4	37.50

ID

ID

ID

104684
104685
104686
104687

104688
104689
104690
104691
104692
104683

104742
104743
104744
104745
104746
104752
104747
104748
104749
104750
104751

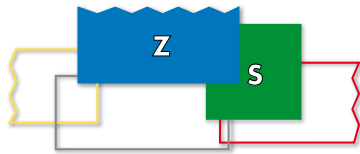

Z362VS-3



Z370VS-3



Z373VS-3

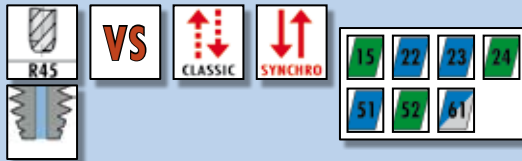

Z362VS-3

Z370VS-3

Z370VS-3

Z373VS-3



PM

PM

PM

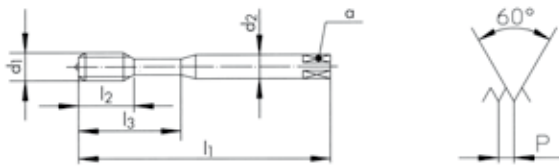

6HX

6HX

4HX

6HX

∅ d ₁ M	P mm	l ₁ mm	l ₂ mm	l ₃ mm	d ₂ mm	a mm		
*3	0.50	56	5.5	18	3.5	2.7	3	2.50
4	0.70	63	7.5	21	4.5	3.4	3	3.30
5	0.80	70	9.0	25	6.0	4.9	3	4.20
6	1.00	80	11.0	30	6.0	4.9	3	5.00
8	1.25	90	12.5	35	8.0	6.2	3	6.80
10	1.50	100	14.0	39	10.0	8.0	3	8.50

ID

111504
111505
111506
111507
111508
111509

* Z360VS-3

∅ d ₁ M	P mm	l ₁ mm	l ₂ mm	l ₃ mm	d ₂ h6 mm	a mm		
3	0.50	56	5.5	18	3.5(h9)	2.7	3	2.50
4	0.70	63	7.5	21	4.5(h9)	3.4	3	3.30
5	0.80	70	9.0	25	6.0	4.9	3	4.20
6	1.00	80	11.0	30	6.0	4.9	3	5.00
8	1.25	90	12.5	35	8.0	6.2	3	^Δ 6.80
10	1.50	100	14.0	39	10.0	8.0	3	8.50











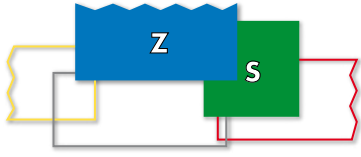









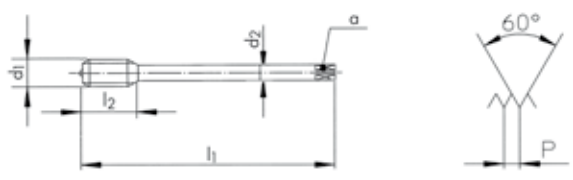

ID











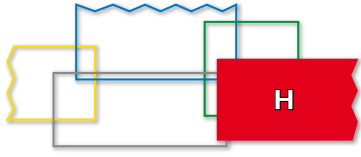

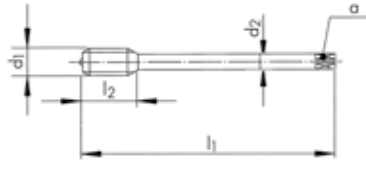

ID

ID

162776 165324 165236
162777 165325 165237
162778 165326 165238
162779 165327 165239
162780 165328 165240
162781 165438 165241

^Δ 4HX = = 6.70

									Z462VS-3	Z470VS-3	Z473VS-3			
<p>Z462VS-3</p>  														
<p>Z470VS-3</p>  														
<p>Z473VS-3</p>  														
														
														
														
$\varnothing d_1$ M	P mm	l_1 mm	l_2 mm	d_2 mm	α mm			ID						
12	1.75	110	14.0	9.0	7.0	4	10.20	111510						
14	2.00	110	14.0	11.0	9.0	4	12.00	* 148169						
16	2.00	110	18.0	12.0	9.0	4	14.00	111511						
20	2.50	140	24.0	16.0	12.0	4	17.50	111512						
24	3.00	160	27.0	18.0	14.5	4	21.00	* 111620						
$\varnothing d_1$ M	P mm	l_1 mm	l_2 mm	d_2 h6 mm	α mm			ID	ID					
12	1.75	110	14.0	*10.0	*8.0	4	10.20	162782	165242					
14	2.00	110	14.0	*12.0	*9.0	4	12.00	162783	* 165243					
16	2.00	110	18.0	12.0	9.0	4	14.00	162784	165244					
18	2.50	125	21.0	14.0	11.0	4	15.50	170643						
20	2.50	140	24.0	16.0	12.0	4	17.50	162785	165234					
22	2.50	140	24.0	16.0	12.0	4	19.50	175190						
24	3.00	160	27.0	16.0	12.0	4	21.00	162786	165235					
* Norme DC / * DC Norm / * Norma DC														

									H420-4	H420TC-4						
									 							
H420-4																
H420TC-4	 TiCN															
 									 							
									 							
Ø d ₁ M	P mm	l ₁ mm	l ₂ mm	d ₂ mm	α mm				ID	ID						
12	1.75	110	24.0	9.0	7.0	4	10.20		101275	110912						
14	2.00	110	28.0	11.0	9.0	4	12.00		101277							
16	2.00	110	30.0	12.0	9.0	4	14.00		101279	111612						
18	2.50	125	33.0	14.0	11.0	4	15.50		101281							
20	2.50	140	36.0	16.0	12.0	4	17.50		101284							
24	3.00	160	39.0	18.0	14.5	4	21.00		101286							
27	3.00	160	42.0	20.0	16.0	4	24.00		101287							
30	3.50	180	45.0	22.0	18.0	4	26.50		101288							
36	4.00	200	51.0	28.0	22.0	4	32.00		101289							

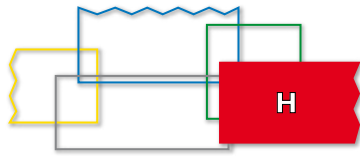

H350-3



H350TC-3



H350-3

H350-3

H350TC-3

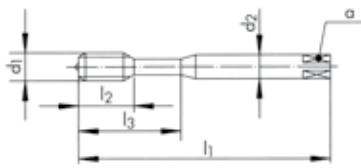

$\varnothing d_1$ M	P mm	l_1 mm	l_2 mm	l_3 mm	d_2 mm	a mm		$6H$ $\rightarrow \leftarrow$
2	0.40	45	7.0		2.8	2.1	2	1.60
2.5	0.45	50	9.0		2.8	2.1	3	2.05
3	0.50	56	5.5	18	3.5	2.7	3	2.50
3.5	0.60	56	6.5	20	4.0	3.0	3	2.90
4	0.70	63	7.5	21	4.5	3.4	3	3.30
4.5	0.75	70	9.0	25	6.0	4.9	3	3.75
5	0.80	70	9.0	25	6.0	4.9	3	4.20
6	1.00	80	11.0	30	6.0	4.9	3	5.00
8	1.25	90	12.5	35	8.0	6.2	3	6.80
10	1.50	100	14.0	39	10.0	8.0	3	8.50

ID

ID

$6H$
+ mm

ID

101238

146451

101239

144957

101242

101241

0.020

111835

101243

101245

101244

0.022

111607

101246

101248

101247

0.024

111610

101251

101250

0.026

111500

101255

101254

0.028

110963

101237

101236

0.032

111454

M ISO DIN 13

≤ Ø 25.4 > Ø 25.4

PM HSSE



									H450-3	H450-3	H450TC-3	
H450-3												
H450TC-3												
Ø d ₁ M	P mm	l ₁ mm	l ₂ mm	d ₂ mm	α mm				ID	ID ^{6H} + mm	ID	
12	1.75	110	14.0	9.0	7.0	4	10.20		101305	101304	0.034	111501
14	2.00	110	14.0	11.0	9.0	4	12.00		101307			
16	2.00	110	18.0	12.0	9.0	4	14.00		101309			111605
18	2.50	125	21.0	14.0	11.0	4	15.50		101311			
20	2.50	140	24.0	16.0	12.0	4	17.50		101313			
22	2.50	140	24.0	18.0	14.5	4	19.50		101315			
24	3.00	160	27.0	18.0	14.5	4	21.00		101318			
27	3.00	160	27.0	20.0	16.0	4	24.00		101320			
30	3.50	180	30.0	22.0	18.0	4	26.50		101323			
36	4.00	200	36.0	28.0	22.0	4	32.00		101324			
42	4.50	200	40.0	32.0	24.0	4	37.50		101325			

										S320VS-4	S320VS-4	S420VS-4	
\varnothing d ₁ M	P mm	l ₁ mm	l ₂ mm	l ₃ mm	d ₂ mm	a mm				ID	ID	ID	
3	0.50	56	12.0	18	3.5	2.7	3		2.50	111596	* 165318		
4	0.70	63	14.0	21	4.5	3.4	3		3.30	111597	165319		
5	0.80	70	15.0	25	6.0	4.9	3		4.20	111598	165320		
6	1.00	80	17.0	30	6.0	4.9	3		5.00	111599	165321		
8	1.25	90	20.0	35	8.0	6.2	3	Δ	6.80	111600	165322		
10	1.50	100	22.0	39	10.0	8.0	3		8.50	111601	165323		
12	1.75	110	24.0		9.0	7.0	4		10.20			111602	
14	2.00	110	30.0		11.0	9.0	4		12.50			* 162537	
16	2.00	110	30.0		12.0	9.0	4		14.00			111603	
20	2.50	140	36.0		16.0	12.0	4		17.50			111604	

Δ **4HX** = = 6.70

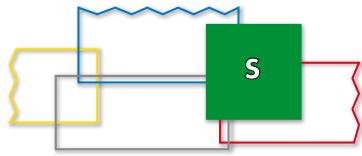

S360VS-3	S460VS-3	SA390-3	SA390-3
----------	----------	---------	---------



S360VS-3



13	15	24	52
----	----	----	----

S460VS-3



13	15	24	52
----	----	----	----

aero

SA390-3



53

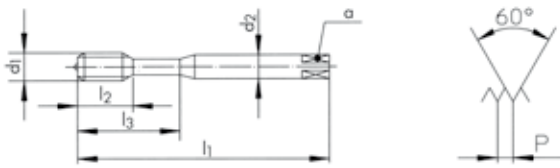

6HX	6HX	4HX	6HX

∅ d ₁ M	P mm	l ₁ mm	l ₂ mm	l ₃ mm	d ₂ mm	α mm		
3	0.50	56	5.5	18	3.5	2.7	3	2.50
4	0.70	63	7.5	21	4.5	3.4	3	3.30
5	0.80	70	9.0	25	6.0	4.9	3	4.20
6	1.00	80	11.0	30	6.0	4.9	3	5.00
8	1.25	90	12.5	35	8.0	6.2	3	6.80
10	1.50	100	14.0	39	10.0	8.0	3	8.50
12	1.75	110	14.0		9.0	7.0	4	10.20
14	2.00	110	14.0		11.0	9.0	4	12.00
16	2.00	110	18.0		12.0	9.0	4	14.00
20	2.50	140	24.0		16.0	12.0	4	17.50
24	3.00	160	27.0		18.0	14.5	4	21.00

ID	ID
111513	
111514	
111515	
111516	
111517	
111518	
	111519
	148171
	111520
	111521
	111606

∅ d ₁ M	P mm	l ₁ mm	l ₂ mm	d ₂ mm	α mm		
4	0.70	63	14.0	4.5	3.4	3	3.30
5	0.80	70	15.0	6.0	4.9	3	4.20
6	1.00	80	20.0	6.0	4.9	3	5.00
8	1.25	90	25.0	8.0	6.2	3	Δ 6.80
10	1.50	100	30.0	10.0	8.0	3	8.50
12	1.75	110	35.0	12.0	9.0	4	10.20
14	2.00	110	40.0	16.0	12.0	4	12.00
16	2.00	110	40.0	16.0	12.0	4	14.00

ID	ID
149673	149674
149693	149694
149707	149708
149736	149737
149754	149755
	149775
	* 149792
	* 149816



aero

										SA320-4	SA350-3	TL320VS-4	TL351VS-3																																																																																																																																				
<div style="display: flex; justify-content: space-between;"> <div style="width: 45%;"> <p>SA320-4 </p> <p>SA350-3 </p> </div> <div style="width: 45%;"> <p>TL320VS-4 </p> <p>TL351VS-3 </p> </div> </div>																																																																																																																																																	
<div style="display: flex; justify-content: space-between;"> <div style="width: 45%;"> <p>TL320VS-4 </p> <p>TL351VS-3 </p> </div> <div style="width: 45%;"> <p>SA320-4 </p> <p>SA350-3 </p> </div> </div>																																																																																																																																																	
<table border="1"> <thead> <tr> <th>$\varnothing d_1$</th> <th>P</th> <th>l_1</th> <th>l_2</th> <th>l_3</th> <th>d_2</th> <th>α</th> <th></th> <th></th> <th>ID</th> <th>ID</th> <th>ID</th> <th>ID</th> </tr> <tr> <th>M</th> <th>mm</th> <th>mm</th> <th>mm</th> <th>mm</th> <th>mm</th> <th>mm</th> <th></th> <th></th> <th></th> <th></th> <th></th> <th></th> </tr> </thead> <tbody> <tr><td>3</td><td>0.50</td><td>56</td><td>12.0</td><td></td><td>3.5</td><td>2.7</td><td>3</td><td>2.50</td><td>147975</td><td>147987</td><td>152006</td><td>152012</td></tr> <tr><td>4</td><td>0.70</td><td>63</td><td>14.0</td><td></td><td>4.5</td><td>3.4</td><td>3</td><td>3.30</td><td>147976</td><td>147988</td><td>152007</td><td>152013</td></tr> <tr><td>5</td><td>0.80</td><td>70</td><td>15.0</td><td></td><td>6.0</td><td>4.9</td><td>3</td><td>4.20</td><td>147977</td><td>147989</td><td>152008</td><td>152014</td></tr> <tr><td>6</td><td>1.00</td><td>80</td><td>15.0</td><td>23</td><td>6.0</td><td>4.9</td><td>3</td><td>5.00</td><td>147978</td><td>147990</td><td>152009</td><td>152015</td></tr> <tr><td>8</td><td>1.25</td><td>90</td><td>18.0</td><td>29</td><td>8.0</td><td>6.2</td><td>3</td><td>6.70</td><td>147979</td><td>147991</td><td>152010</td><td>152016</td></tr> <tr><td>10</td><td>1.50</td><td>100</td><td>20.0</td><td>33</td><td>10.0</td><td>8.0</td><td>3</td><td>8.50</td><td>147980</td><td>147992</td><td>152011</td><td>152017</td></tr> </tbody> </table>										$\varnothing d_1$	P	l_1	l_2	l_3	d_2	α			ID	ID	ID	ID	M	mm	mm	mm	mm	mm	mm							3	0.50	56	12.0		3.5	2.7	3	2.50	147975	147987	152006	152012	4	0.70	63	14.0		4.5	3.4	3	3.30	147976	147988	152007	152013	5	0.80	70	15.0		6.0	4.9	3	4.20	147977	147989	152008	152014	6	1.00	80	15.0	23	6.0	4.9	3	5.00	147978	147990	152009	152015	8	1.25	90	18.0	29	8.0	6.2	3	6.70	147979	147991	152010	152016	10	1.50	100	20.0	33	10.0	8.0	3	8.50	147980	147992	152011	152017	<table border="1"> <thead> <tr> <th>ID</th> <th>ID</th> <th>ID</th> <th>ID</th> </tr> </thead> <tbody> <tr><td>147975</td><td>147987</td><td>152006</td><td>152012</td></tr> <tr><td>147976</td><td>147988</td><td>152007</td><td>152013</td></tr> <tr><td>147977</td><td>147989</td><td>152008</td><td>152014</td></tr> <tr><td>147978</td><td>147990</td><td>152009</td><td>152015</td></tr> <tr><td>147979</td><td>147991</td><td>152010</td><td>152016</td></tr> <tr><td>147980</td><td>147992</td><td>152011</td><td>152017</td></tr> </tbody> </table>				ID	ID	ID	ID	147975	147987	152006	152012	147976	147988	152007	152013	147977	147989	152008	152014	147978	147990	152009	152015	147979	147991	152010	152016	147980	147992	152011	152017
$\varnothing d_1$	P	l_1	l_2	l_3	d_2	α			ID	ID	ID	ID																																																																																																																																					
M	mm	mm	mm	mm	mm	mm																																																																																																																																											
3	0.50	56	12.0		3.5	2.7	3	2.50	147975	147987	152006	152012																																																																																																																																					
4	0.70	63	14.0		4.5	3.4	3	3.30	147976	147988	152007	152013																																																																																																																																					
5	0.80	70	15.0		6.0	4.9	3	4.20	147977	147989	152008	152014																																																																																																																																					
6	1.00	80	15.0	23	6.0	4.9	3	5.00	147978	147990	152009	152015																																																																																																																																					
8	1.25	90	18.0	29	8.0	6.2	3	6.70	147979	147991	152010	152016																																																																																																																																					
10	1.50	100	20.0	33	10.0	8.0	3	8.50	147980	147992	152011	152017																																																																																																																																					
ID	ID	ID	ID																																																																																																																																														
147975	147987	152006	152012																																																																																																																																														
147976	147988	152007	152013																																																																																																																																														
147977	147989	152008	152014																																																																																																																																														
147978	147990	152009	152015																																																																																																																																														
147979	147991	152010	152016																																																																																																																																														
147980	147992	152011	152017																																																																																																																																														
<table border="1"> <thead> <tr> <th>$\varnothing d_1$</th> <th>P</th> <th>l_1</th> <th>l_2</th> <th>l_3</th> <th>d_2</th> <th>α</th> <th></th> <th></th> <th>ID</th> <th>ID</th> <th>ID</th> <th>ID</th> </tr> <tr> <th>M</th> <th>mm</th> <th>mm</th> <th>mm</th> <th>mm</th> <th>mm</th> <th>mm</th> <th></th> <th></th> <th></th> <th></th> <th></th> <th></th> </tr> </thead> <tbody> <tr><td>3</td><td>0.50</td><td>56</td><td>12.0</td><td></td><td>3.5</td><td>2.7</td><td>3</td><td>2.50</td><td>147981</td><td>147993</td><td>148001</td><td>148000</td></tr> <tr><td>4</td><td>0.70</td><td>63</td><td>14.0</td><td></td><td>4.5</td><td>3.4</td><td>3</td><td>3.30</td><td>147982</td><td>147994</td><td>148003</td><td>148002</td></tr> <tr><td>5</td><td>0.80</td><td>70</td><td>15.0</td><td></td><td>6.0</td><td>4.9</td><td>3</td><td>4.20</td><td>147983</td><td>147995</td><td>148007</td><td>148006</td></tr> <tr><td>6</td><td>1.00</td><td>80</td><td>15.0</td><td>23</td><td>6.0</td><td>4.9</td><td>3</td><td>5.00</td><td>147984</td><td>147996</td><td>148011</td><td>148010</td></tr> <tr><td>8</td><td>1.25</td><td>90</td><td>18.0</td><td>29</td><td>8.0</td><td>6.2</td><td>3</td><td>6.80</td><td>147985</td><td>147997</td><td>148020</td><td>148018</td></tr> <tr><td>10</td><td>1.50</td><td>100</td><td>20.0</td><td>33</td><td>10.0</td><td>8.0</td><td>3</td><td>8.50</td><td>147986</td><td>147998</td><td>148027</td><td>148025</td></tr> </tbody> </table>										$\varnothing d_1$	P	l_1	l_2	l_3	d_2	α			ID	ID	ID	ID	M	mm	mm	mm	mm	mm	mm							3	0.50	56	12.0		3.5	2.7	3	2.50	147981	147993	148001	148000	4	0.70	63	14.0		4.5	3.4	3	3.30	147982	147994	148003	148002	5	0.80	70	15.0		6.0	4.9	3	4.20	147983	147995	148007	148006	6	1.00	80	15.0	23	6.0	4.9	3	5.00	147984	147996	148011	148010	8	1.25	90	18.0	29	8.0	6.2	3	6.80	147985	147997	148020	148018	10	1.50	100	20.0	33	10.0	8.0	3	8.50	147986	147998	148027	148025	<table border="1"> <thead> <tr> <th>ID</th> <th>ID</th> <th>ID</th> <th>ID</th> </tr> </thead> <tbody> <tr><td>147981</td><td>147993</td><td>148001</td><td>148000</td></tr> <tr><td>147982</td><td>147994</td><td>148003</td><td>148002</td></tr> <tr><td>147983</td><td>147995</td><td>148007</td><td>148006</td></tr> <tr><td>147984</td><td>147996</td><td>148011</td><td>148010</td></tr> <tr><td>147985</td><td>147997</td><td>148020</td><td>148018</td></tr> <tr><td>147986</td><td>147998</td><td>148027</td><td>148025</td></tr> </tbody> </table>				ID	ID	ID	ID	147981	147993	148001	148000	147982	147994	148003	148002	147983	147995	148007	148006	147984	147996	148011	148010	147985	147997	148020	148018	147986	147998	148027	148025
$\varnothing d_1$	P	l_1	l_2	l_3	d_2	α			ID	ID	ID	ID																																																																																																																																					
M	mm	mm	mm	mm	mm	mm																																																																																																																																											
3	0.50	56	12.0		3.5	2.7	3	2.50	147981	147993	148001	148000																																																																																																																																					
4	0.70	63	14.0		4.5	3.4	3	3.30	147982	147994	148003	148002																																																																																																																																					
5	0.80	70	15.0		6.0	4.9	3	4.20	147983	147995	148007	148006																																																																																																																																					
6	1.00	80	15.0	23	6.0	4.9	3	5.00	147984	147996	148011	148010																																																																																																																																					
8	1.25	90	18.0	29	8.0	6.2	3	6.80	147985	147997	148020	148018																																																																																																																																					
10	1.50	100	20.0	33	10.0	8.0	3	8.50	147986	147998	148027	148025																																																																																																																																					
ID	ID	ID	ID																																																																																																																																														
147981	147993	148001	148000																																																																																																																																														
147982	147994	148003	148002																																																																																																																																														
147983	147995	148007	148006																																																																																																																																														
147984	147996	148011	148010																																																																																																																																														
147985	147997	148020	148018																																																																																																																																														
147986	147998	148027	148025																																																																																																																																														

aero

SA420-4 SA450-3 TL420VS-4 TL451VS-3



SA420-4



SA450-3



TL420VS-4



VS

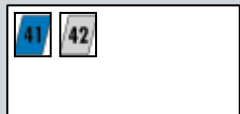

TL451VS-3



VS

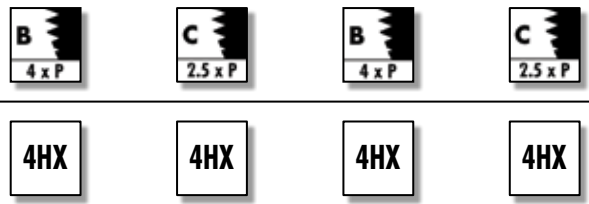
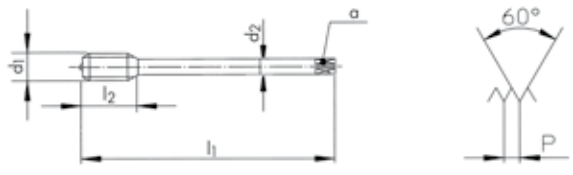
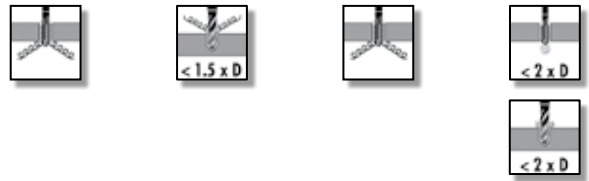
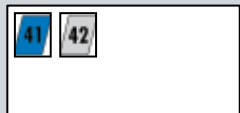

4HX 4HX 4HX 4HX

$\varnothing d_1$ M	P mm	l_1 mm	l_2 mm	d_2 mm	α mm		
12	1.75	110	24.0	9.0	7.0	4	10.20
14	2.00	110	28.0	11.0	9.0	4	12.00
16	2.00	110	30.0	12.0	9.0	4	14.00

ID	ID	ID	ID
148096	152189	152192	152195
* 152187			
* 152188	* 152191		152197

6HX 6HX 6HX 6HX

$\varnothing d_1$ M	P mm	l_1 mm	l_2 mm	d_2 mm	α mm		
12	1.75	110	24.0	9.0	7.0	4	10.20
14	2.00	110	28.0	11.0	9.0	4	12.00
16	2.00	110	30.0	12.0	9.0	4	14.00

ID	ID	ID	ID
152198	152201	152204	148028
* 152199	* 152202	* 152205	152207
* 152200	152203	* 152206	148029

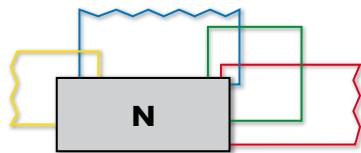
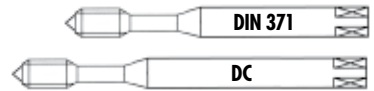

GG350NV-3 GG350TC-3 GG353TC-3 GG550NV-3



GG350NV-3



GG350TC-3

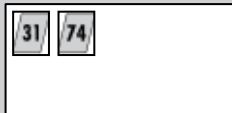

GG353TC-3

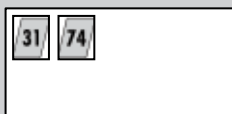

GG550NV-3

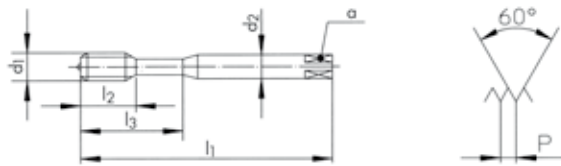
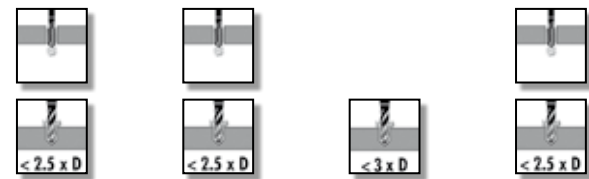
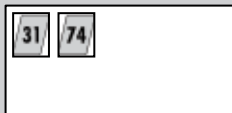

6HX 6HX 6HX 6HX

$\varnothing d_1$ M	P mm	l_1 mm	l_2 mm	l_3 mm	d_2 mm	α mm		
3	0.50	56	12.0	18	3.5	2.7	3	2.50
4	0.70	63	14.0	21	4.5	3.4	3	3.30
5	0.80	70	15.0	25	6.0	4.9	3	4.20
6	1.00	80	17.0	30	6.0	4.9	3	5.00
8	1.25	90	20.0	35	8.0	6.2	4	6.80
10	1.50	100	22.0	39	10.0	8.0	4	8.50

ID ID

101172	101178
101173	101179
101174	101180
101175	101181
101076	101182
101171	101177

$\varnothing d_1$ M	P mm	l_1 mm	l_2 mm	l_3 mm	d_2 h6 mm	α mm		
5	0.80	70	15.0	25	6.0	4.9	3	4.20
6	1.00	80	17.0	30	6.0	4.9	3	5.00
8	1.25	90	20.0	35	8.0	6.2	4	6.80
10	1.50	100	22.0	39	10.0	8.0	4	8.50

ID
144947
147710
147711
146708

$\varnothing d_1$ M	P mm	l_1 mm	l_2 mm	l_3 mm	d_2 mm	α mm		
4	0.70	112	14.0	21	4.5	3.4	3	3.30
5	0.80	125	15.0	25	6.0	4.9	3	4.20
6	1.00	125	17.0	30	6.0	4.9	3	5.00

ID
101196
101197
101198

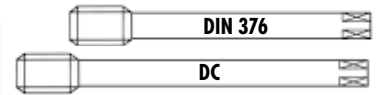

									GG450NV-3	GG450TC-3	GG453TC-3	GG650NV-3
GG450NV-3												
GG450TC-3												
GG453TC-3												
GG650NV-3												
$\varnothing d_1$	P	l_1	l_2	d_2	α				ID	ID		
M	mm	mm	mm	mm	mm							
8	1.25	90	20.0	6.0	4.9	4		6.80	101189	101194		
10	1.50	100	22.0	7.0	5.5	4		8.50	101183	101195		
12	1.75	110	24.0	9.0	7.0	4		10.20	101184	101190		
14	2.00	110	28.0	11.0	9.0	4		12.00	101185	101191		
16	2.00	110	30.0	12.0	9.0	4		14.00	101186	101192		
20	2.50	140	36.0	16.0	12.0	4		17.50	101187	101193		
24	3.00	160	39.0	18.0	14.5	4		21.00	101188			
$\varnothing d_1$	P	l_1	l_2	d_2 h6	α				ID			
M	mm	mm	mm	mm	mm							
12	1.75	110	24.0	*10.0	*8.0	4		10.20	146707			
16	2.00	110	30.0	12.0	9.0	4		14.00	162796			
									* Norme DC / * DC Norm / * Norma DC			
$\varnothing d_1$	P	l_1	l_2	d_2	α				ID			
M	mm	mm	mm	mm	mm							
8	1.25	140	20.0	6.0	4.9	4		6.80	101203			
10	1.50	160	22.0	7.0	5.5	4		8.50	101199			
12	1.75	180	24.0	9.0	7.0	4		10.20	101200			
16	2.00	200	30.0	12.0	9.0	4		14.00	101201			
20	2.50	224	36.0	16.0	12.0	4		17.50	101202			



Uniquement pour taraudage synchrone
Nur für Synchrobearbeitung
Only for rigid tapping
Solo per maschiatura sincrona
Solo para rosado sincronizado

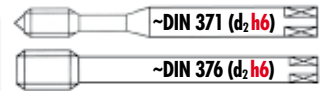

RTS Rigid Tapping Synchro

RTS320VS-4



11	12	13	14
15	21	22	31
32	61	63	72
73	74		

RTS420VS-4



RTS323VS-4



11	12	13	14
15	21	22	31
32	61	63	72
73	74		

RTS423VS-4



RTS320VS-4

RTS420VS-4

RTS323VS-4

RTS423VS-4

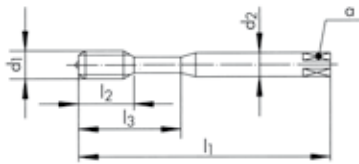

∅ d ₁ M	P mm	l ₁ mm	l ₂ mm	l ₃ mm	d ₂ h ₆ mm	a mm		
*2	0.40	45	8.0		2.8(h9)	2.1	2	1.60
2.5	0.45	50	10.0		2.8(h9)	2.1	3	2.05
3	0.50	56	5.5	18	3.5(h9)	2.7	3	2.50
4	0.70	63	7.5	21	4.5(h9)	3.4	3	3.30
5	0.80	70	9.0	25	6.0	4.9	3	4.20
6	1.00	80	11.0	30	6.0	4.9	3	5.00
8	1.25	90	12.5	35	8.0	6.2	3	6.80
10	1.50	100	14.0	39	10.0	8.0	3	8.50
12	1.75	110	14.0		*10.0	*8.0	3	10.20
14	2.00	110	14.0		*12.0	*9.0	3	12.00
16	2.00	110	18.0		12.0	9.0	3	14.00
20	2.50	140	24.0		16.0	12.0	4	17.50
24	3.00	160	27.0		16.0	12.0	4	21.00

ID

ID

ID

ID

143532

143534

150601

150603

150605

150606

150610

150611

150620

150621

150635

150636

151863

151864

162535

150670

150671

150679

162787

* Norme DC / * DC Norm / * Norma DC

* RTS320VS-3



sur demande
auf Anfrage
on request
su richiesta
sobre pedido



Uniquement pour taraudage synchro
Nur für Synchrobearbeitung
Only for rigid tapping
Solo per maschiatura sincrona
Solo para roscado sincronizado

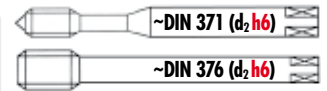

RTS Rigid Tapping Synchro

RTS362VS-3



RTS462VS-3



RTS365VS-3



RTS465VS-3



RTS362VS-3

RTS462VS-3

RTS365VS-3

RTS465VS-3

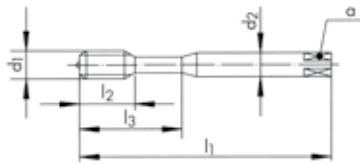

Ø d ₁ M	P mm	l ₁ mm	l ₂ mm	l ₃ mm	d ₂ h6 mm	α mm		
*2	0.40	45	7.0		2.8 (h9)	2.1	3	1.60
*2.5	0.45	50	9.0		2.8 (h9)	2.1	3	2.05
3	0.50	56	5.5	18	3.5 (h9)	2.7	3	2.50
4	0.70	63	7.5	21	4.5 (h9)	3.4	3	3.30
5	0.80	70	9.0	25	6.0	4.9	3	4.20
6	1.00	80	11.0	30	6.0	4.9	3	5.00
8	1.25	90	12.5	35	8.0	6.2	3	6.80
10	1.50	100	14.0	39	10.0	8.0	3	8.50
12	1.75	110	14.0		*10.0	*8.0	3	10.20
14	2.00	110	14.0		*12.0	*9.0	3	12.00
16	2.00	110	18.0		12.0	9.0	3	14.00
20	2.50	140	24.0		16.0	12.0	4	17.50
24	3.00	160	27.0		16.0	12.0	4	21.00

* Norme DC / * DC Norm / * Norma DC

* RTS360VS-3



sur demande
auf Anfrage
on request
su richiesta
sobre pedido



Uniquement pour taraudage synchrone
Nur für Synchrobearbeitung
Only for rigid tapping
Solo per maschiatura sincrona
Solo para roscado sincronizado



RTS Rigid Tapping Synchro

RTS362VS-5



VS

11	12	13	14
15	21	22	31
32	61	63	72
73	74		

RTS365VS-5



VS

11	12	13	14
15	21	22	31
32	61	63	72
73	74		

RTS362VS-3



VS

11	12	13	14
15	21	22	31
32	61	63	72
73	74		

RTS362VS-5

RTS365VS-5

RTS362VS-3

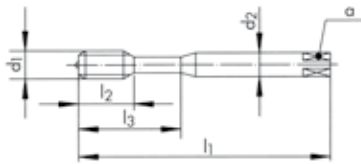

∅ d ₁ M	P mm	l ₁ mm	l ₂ mm	l ₃ mm	d ₂ h6 mm	a mm		
3	0.50	56	5.5	18	3.5 (h9)	2.7	3	2.50
4	0.70	63	7.5	21	4.5 (h9)	3.4	3	3.30
5	0.80	70	9.0	25	6.0	4.9	3	4.20
6	1.00	80	11.0	30	6.0	4.9	3	5.00
8	1.25	90	12.5	35	8.0	6.2	3	6.80
10	1.50	100	14.0	39	10.0	8.0	3	8.50

ID

ID

157648

157650

157652

162791

158074

151803

158076

157821

153286

157823

∅ d ₁ M	P mm	l ₁ mm	l ₂ mm	l ₃ mm	d ₂ h6 mm	a mm			6H
3	0.50	56	5.5	18	3.5 (h9)	2.7	3	2.50	
4	0.70	63	7.5	21	4.5 (h9)	3.4	3	3.35	
5	0.80	70	9.0	25	6.0	4.9	3	4.25	
6	1.00	80	11.0	30	6.0	4.9	3	5.00	
8	1.25	90	12.5	35	8.0	6.2	3	6.80	
10	1.50	100	14.0	39	10.0	8.0	3	8.50	

ID

6H
+ mm

162797 0.020

162798 0.022

162799 0.024

162800 0.026

162801 0.028

162802 0.032



sur demande
auf Anfrage
on request
su richiesta
sobre pedido



Uniquement pour taraudage synchrone
Nur für Synchrobearbeitung
Only for rigid tapping
Solo per maschiatura sincrona
Solo para roscado sincronizado

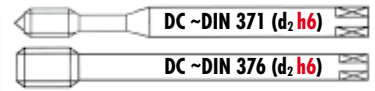

RTS Rigid Tapping Synchro

RTS523VS-4



11	12	13	14
15	21	22	31
32	61	63	72
73	74		

RTS623VS-4



RTS565VS-3



11	12	13	14
15	21	22	31
32	61	63	72
73	74		

RTS665VS-3



RTS523VS-4 RTS623VS-4 RTS565VS-3 RTS665VS-3

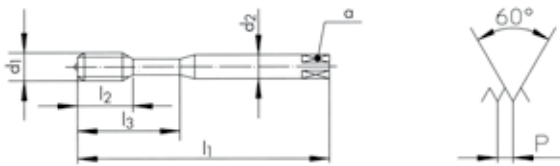

Ø d ₁ M	P mm	l ₁ mm	l ₂ mm	l ₃ mm	d ₂ h6 mm	a mm		
5	0.80	125	9.0	25	6.0	4.9	3	4.20
6	1.00	125	11.0	30	6.0	4.9	3	5.00
8	1.25	140	12.5	35	8.0	6.2	3	6.80
10	1.50	160	14.0	39	10.0	8.0	3	8.50
12	1.75	180	14.0		*10.0	*8.0	3	10.20
16	2.00	200	18.0		12.0	9.0	3	14.00

* Norme DC / * DC Norm / * Norma DC

Ø d ₁ M	P mm	l ₁ mm	l ₂ mm	l ₃ mm	d ₂ h6 mm	a mm		
6	1.00	125	11.0	30	6.0	4.9	3	5.00
8	1.25	140	12.5	35	8.0	6.2	3	6.80
10	1.50	160	14.0	39	10.0	8.0	3	8.50
12	1.75	180	14.0		*10.0	*8.0	3	10.20
16	2.00	200	18.0		12.0	9.0	3	14.00

* Norme DC / * DC Norm / * Norma DC



sur demande
auf Anfrage
on request
su richiesta
sobre pedido

K

K313TC-3

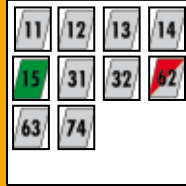

K413TC-3

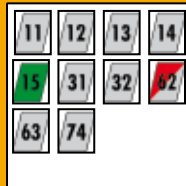

K313TC-3

K413TC-3



6HX

6HX

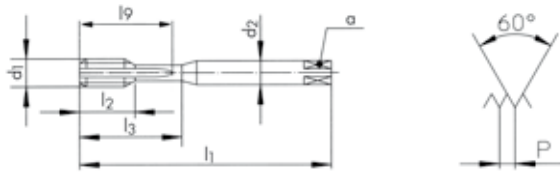

$\varnothing d_1$ M	P mm	l_1 mm	l_2 mm	l_3 mm	l_9 mm	d_2 mm	a mm		
6	1.00	80	17.0	30	28.0	6.0	4.9	3	5.00
8	1.25	90	20.0	35	33.0	8.0	6.2	3	6.80
10	1.50	100	22.0	39	37.0	10.0	8.0	3	8.50
12	1.75	110	24.0	42.0	42.0	9.0	7.0	3	10.20
14	2.00	110	28.0	49.0	49.0	11.0	9.0	3	12.00
16	2.00	110	30.0	56.0	56.0	12.0	9.0	4	14.00
20	2.50	140	36.0	70.0	70.0	16.0	12.0	5	17.50
24	3.00	160	39.0	84.0	84.0	18.0	14.5	5	21.00









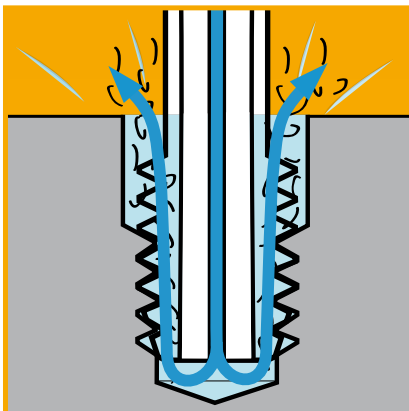

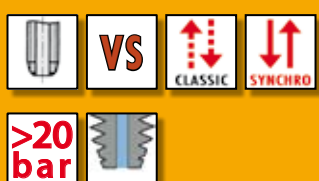
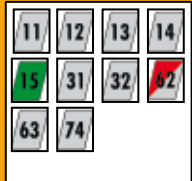

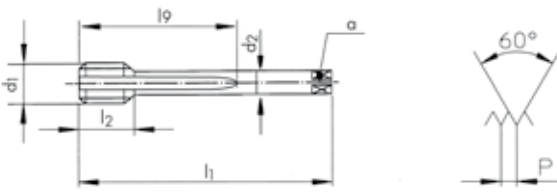

ID





ID

170766
170769
170772

165838
170778
170783
170786
170775



<div style="text-align: center; font-size: 2em; font-weight: bold; color: blue;">K</div>									K613TC-3		K613VS-3											
																						
																						
																						
$\varnothing d_1$ M	P mm	l_1 mm	l_2 mm	l_3 mm	d_2 mm	α mm			ID	ID												
6	1.00	110	17.0	30	4.5	3.4	3	5.00	170646	172699												
8	1.25	110	20.0	40	6.0	4.9	3	6.80	170649	172700												
10	1.50	125	22.0	50	7.0	5.5	3	8.50	170652	172701												
12	1.75	140	24.0	60	9.0	7.0	3	10.20	167982	172702												
14	2.00	140	28.0	70	11.0	9.0	3	12.00	167983													
16	2.00	160	30.0	80	12.0	9.0	4	14.00	167984	170573												
20	2.50	180	36.0	100	16.0	12.0	5	17.50	167985	170576												
24	3.00	200	39.0	120	18.0	14.5	5	21.00	167986	172704												
27	3.00	225	42.0	135	20.0	16.0	5	24.00	167987													
30	3.50	250	45.0	150	22.0	18.0	5	26.50	165542													
33	3.50	280	48.0	165	25.0	20.0	5	29.50	167988													
36	4.00	300	51.0	180	28.0	22.0	6	32.00	167989													
39	4.00	300	55.0	195	32.0	24.0	6	35.00	167990													
42	4.50	355	55.0	210	32.0	24.0	6	37.50	167999													

Vc (m/min)							
M6 - M10		M12 - M16		M20 - M30		M33 - M42	
	32	28		22		18	
	30	25		20		15	
	24	20		16		12	
	15	12		8		6	
	35	30		25		20	

FS FORMING

FS380VS-5



FS380VS-3



FS380VS-5

FS380VS-3

FS380VS-3

FS380VS-3

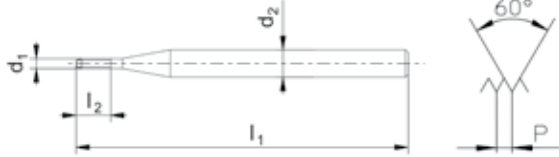

$\varnothing d_1$ M	P mm	l_1 mm	l_2 mm	d_2 mm	a mm	4HX Tol. → ← 6HX
1	0.25	40	3.0	2.5		0.88 +0.02
1.2	0.25	40	3.6	2.5		1.08 +0.02
1.4	0.30	40	4.2	2.5		1.25 +0.02
1.6	0.35	40	4.8	2.5		1.45 +0.02
1.7	0.35	40	5.1	2.5		1.55 +0.02
1.8	0.35	40	5.4	2.5		1.65 +0.02
2	0.40	45	8.0	2.8	2.1	1.80 +0.02
2.5	0.45	50	10.0	2.8	2.1	2.30 +0.02
2.6	0.45	50	10.0	2.8	2.1	2.40 +0.02

ID

ID

ID

ID 6H
+ mm

157171

173452

157172

173455

157173

173458

157174

169779

157175

169782

157175

169785

157176

157180 0.019

157178

157181 0.020

157179

≤ M1.5 4HX

FS FORMING

FS380DL-5



11	12	13	14
21	22	23	24
41	51	61	63
71	72	73	

FS380DL-3



11	12	13	14
21	22	23	24
41	51	61	63
71	72	73	

FS380DL-5 FS380DL-3 FS380DL-3 FS380DL-3



NEW **NEW** **NEW** **NEW**

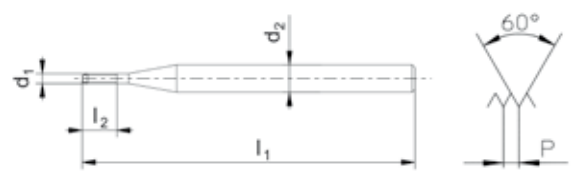

6HX **6HX** **6HX** **6GX**

$\varnothing d_1$ M	P mm	l_1 mm	l_2 mm	d_2 mm	α mm	4HX Tol. 6HX
1	0.25	40	3.0	2.5		0.88 +0.02
1.2	0.25	40	3.6	2.5		1.08 +0.02
1.4	0.30	40	4.2	2.5		1.25 +0.02
1.6	0.35	40	4.8	2.5		1.45 +0.02
1.7	0.35	40	5.1	2.5		1.55 +0.02
1.8	0.35	40	5.4	2.5		1.65 +0.02
2	0.40	45	8.0	2.8	2.1	1.80 +0.02
2.5	0.45	50	10.0	2.8	2.1	2.30 +0.02
2.6	0.45	50	10.0	2.8	2.1	2.40 +0.02

ID	ID	ID	ID	6H + mm
172839	173461			
172840	173464			
172841	173467			
170585	170916			
	172843			
172842	172844			
		158814		172849 0.019
		172845		173246 0.020
		172846		

≤ M1.5 **4HX**

FPS FORMING

FPS380CN-3



CrN

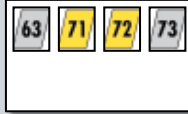

FPS381CN-3



CrN

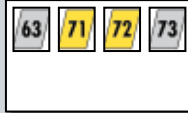

FPS380VS-3



VS



FPS381VS-3



VS

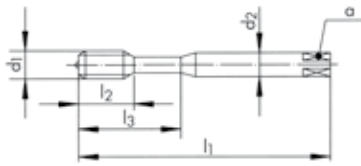

FPS380CN-3

FPS381CN-3

FPS380VS-3

FPS381VS-3



6HX

6HX

6HX

6HX

$\varnothing d_1$ M	P mm	l_1 mm	l_2 mm	l_3 mm	d_2 mm	a mm	6HX Tol. → ←
3	0.50	56	12.0	18	3.5	2.7	2.80 + 0.03
3.5	0.60	56	13.0	20	4.0	3.0	3.25 + 0.03
4	0.70	63	14.0	21	4.5	3.4	3.70 + 0.03
5	0.80	70	15.0	25	6.0	4.9	4.65 + 0.03
6	1.00	80	17.0	30	6.0	4.9	5.55 + 0.05
8	1.25	90	20.0	35	8.0	6.2	7.40 + 0.05
10	1.50	100	22.0	39	10.0	8.0	9.30 + 0.05

ID

ID

ID

ID

166613	166615	166614	166616
166619	166621	166620	166622
166626	166628	166627	166629
166634	166636	166635	166637
166643	166645	166644	166646
166653	166655	166654	166656
166663	166665	166664	166666

6GX

6GX

$\varnothing d_1$ M	P mm	l_1 mm	l_2 mm	l_3 mm	d_2 mm	a mm	6HX Tol. → ←
3	0.50	56	12.0	18	3.5	2.7	2.80 + 0.03
3.5	0.60	56	13.0	20	4.0	3.0	3.25 + 0.03
4	0.70	63	14.0	21	4.5	3.4	3.70 + 0.03
5	0.80	70	15.0	25	6.0	4.9	4.65 + 0.03
6	1.00	80	17.0	30	6.0	4.9	5.55 + 0.05
8	1.25	90	20.0	35	8.0	6.2	7.40 + 0.05
10	1.50	100	22.0	39	10.0	8.0	9.30 + 0.05

ID 6H
+ mm

ID 6H
+ mm

166697	0.020	166617	0.020
166687	0.021	166623	0.021
166688	0.022	166630	0.022
166689	0.024	166638	0.024
166686	0.026	166647	0.026
166740	0.028	166657	0.028
166739	0.032	166667	0.032

FPS FORMING

FPS481VS-3



FPS581VS-3



FPS681VS-3



FPS481VS-3



FPS581VS-3



NEW

FPS681VS-3



NEW



6HX

6HX

6HX

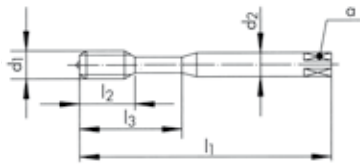

$\varnothing d_1$ M	P mm	l_1 mm	l_2 mm	d_2 mm	α mm	6HX Tol. → ←	ID
12	1.75	110	24.0	9.0	7.0	11.20 + 0.05	166673
14	2.00	110	28.0	11.0	9.0	13.10 + 0.05	166678
16	2.00	110	30.0	12.0	9.0	15.10 + 0.05	166683
20	2.50	140	36.0	16.0	12.0	18.85 + 0.05	168713

$\varnothing d_1$ M	P mm	l_1 mm	l_2 mm	l_3 mm	d_2 mm	α mm	6HX Tol. → ←	ID	ID
3	0.50	100	12.0	18	3.5	2.7	2.80 + 0.03	172824	
4	0.70	125	14.0	21	4.5	3.4	3.70 + 0.03	172826	
5	0.80	140	15.0	25	6.0	4.9	4.65 + 0.03	172828	
6	1.00	160	17.0	30	6.0	4.9	5.55 + 0.05	172830	
8	1.25	180	20.0	35	8.0	6.2	7.40 + 0.05	172832	
10	1.50	200	22.0	39	10.0	8.0	9.30 + 0.05	172834	
12	1.75	224	24.0		9.0	7.0	11.20 + 0.05		172836

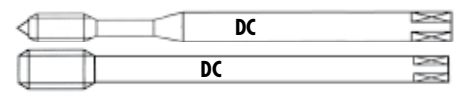
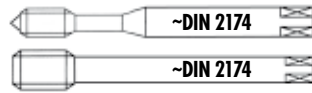

FPS FORMING

FPS384VS-3



FPS484VS-3



FPS584VS-3



FPS684VS-3



FPS384VS-3

FPS484VS-3

FPS584VS-3

FPS684VS-3



6HX

6HX

6HX

6HX

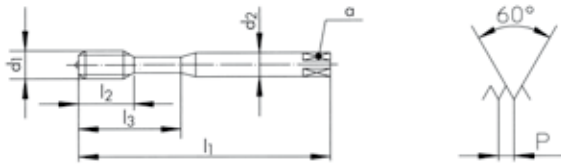

$\varnothing d_1$ M	P mm	l_1 mm	l_2 mm	l_3 mm	d_2 mm	a mm	6HX → ←	Tol.
3	0.50	56	12.0	18	3.5	2.7	2.80	+ 0.03
4	0.70	63	14.0	21	4.5	3.4	3.70	+ 0.03
5	0.80	70	15.0	25	6.0	4.9	4.65	+ 0.03
6	1.00	80	17.0	30	6.0	4.9	5.55	+ 0.05
8	1.25	90	20.0	35	8.0	6.2	7.40	+ 0.05
10	1.50	100	22.0	39	10.0	8.0	9.30	+ 0.05
12	1.75	110	24.0		9.0	7.0	11.20	+ 0.05
14	2.00	110	28.0		11.0	9.0	13.10	+ 0.05
16	2.00	110	30.0		12.0	9.0	15.10	+ 0.05

ID

ID

166737

166738

166640

166650

166660

166670

166675

166680

166685

$\varnothing d_1$ M	P mm	l_1 mm	l_2 mm	l_3 mm	d_2 mm	a mm	6HX → ←	Tol.
3	0.50	100	12.0	18	3.5	2.7	2.80	+ 0.03
4	0.70	125	14.0	21	4.5	3.4	3.70	+ 0.03
5	0.80	140	15.0	25	6.0	4.9	4.65	+ 0.03
6	1.00	160	17.0	30	6.0	4.9	5.55	+ 0.05
8	1.25	180	20.0	35	8.0	6.2	7.40	+ 0.05
10	1.50	200	22.0	39	10.0	8.0	9.30	+ 0.05
12	1.75	224	24.0		9.0	7.0	11.20	+ 0.05

ID

ID

172763

172766

172769

172772

172775

172778

172781

FAS FORMING

FAS380VS-3



VS

12	13	14	15
21	22	23	24
41	51	61	63

FAS381VS-3



VS

12	13	14	15
21	22	23	24
41	51	61	63

FAS481VS-3



VS

12	13	14	15
21	22	23	24
41	51	61	63

FAS380VS-3



FAS381VS-3



FAS481VS-3



6HX

6HX

6HX

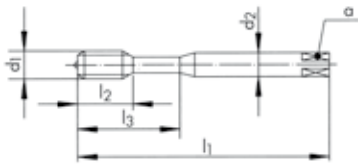

∅ d ₁ M	P mm	l ₁ mm	l ₂ mm	l ₃ mm	d ₂ mm	a mm	6HX Tol. → ←
3	0.50	56	12.0	18	3.5	2.7	2.80 + 0.03
3.5	0.60	56	13.0	20	4.0	3.0	3.25 + 0.03
4	0.70	63	14.0	21	4.5	3.4	3.70 + 0.03
5	0.80	70	15.0	25	6.0	4.9	4.65 + 0.03
6	1.00	80	17.0	30	6.0	4.9	5.55 + 0.05
8	1.25	90	20.0	35	8.0	6.2	7.40 + 0.05
10	1.50	100	22.0	39	10.0	8.0	9.30 + 0.05
12	1.75	110	24.0		9.0	7.0	11.20 + 0.05
14	2.00	110	28.0		11.0	9.0	13.10 + 0.05
16	2.00	110	30.0		12.0	9.0	15.10 + 0.05
20	2.50	140	36.0		16.0	12.0	18.85 + 0.05

ID

ID

ID

170603	166612	
170605	166618	
170607	166624	
170609	166632	
170611	166641	
170616	166651	
170618	166661	166671
		166676
		166681
		168711

6GX

6GX

∅ d ₁ M	P mm	l ₁ mm	l ₂ mm	l ₃ mm	d ₂ mm	a mm	6HX Tol. → ←
3	0.50	56	12.0	18	3.5	2.7	2.80 + 0.03
3.5	0.60	56	13.0	20	4.0	3.0	3.25 + 0.03
4	0.70	63	14.0	21	4.5	3.4	3.70 + 0.03
5	0.80	70	15.0	25	6.0	4.9	4.65 + 0.03
6	1.00	80	17.0	30	6.0	4.9	5.55 + 0.05
8	1.25	90	20.0	35	8.0	6.2	7.40 + 0.05
10	1.50	100	22.0	39	10.0	8.0	9.30 + 0.05
12	1.75	110	24.0		9.0	7.0	11.20 + 0.05
14	2.00	110	28.0		11.0	9.0	13.10 + 0.05
16	2.00	110	30.0		12.0	9.0	15.10 + 0.05

ID

6H

ID

6H

ID	6H + mm	ID	6H + mm
166703	0.020		
* 166704	0.021		
166705	0.022		
166706	0.024		
166707	0.026		
166708	0.028		
166709	0.032		
		166710	0.034
		166711	0.038
		166712	0.038

FAS FORMING

FAS384VS-3

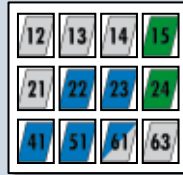

FAS484VS-3

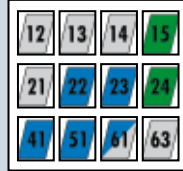

FAS384VS-3

FAS484VS-3

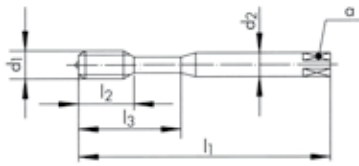

6HX

6HX

$\varnothing d_1$ M	P mm	l_1 mm	l_2 mm	l_3 mm	d_2 mm	a mm	6HX → ←	Tol.
3	0.50	56	12.0	18	3.5	2.7	2.80	+ 0.03
4	0.70	63	14.0	21	4.5	3.4	3.70	+ 0.03
5	0.80	70	15.0	25	6.0	4.9	4.65	+ 0.03
6	1.00	80	17.0	30	6.0	4.9	5.55	+ 0.05
8	1.25	90	20.0	35	8.0	6.2	7.40	+ 0.05
10	1.50	100	22.0	39	10.0	8.0	9.30	+ 0.05
12	1.75	110	24.0		9.0	7.0	11.20	+ 0.05
14	2.00	110	28.0		11.0	9.0	13.10	+ 0.05
16	2.00	110	30.0		12.0	9.0	15.10	+ 0.05

ID

ID

166741

166742

166690

166691

166692

166693

166694

* 166695

166696

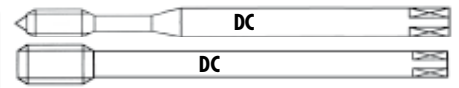

FAS FORMING

FAS581VS-3 **EL VS**

FAS681VS-3 **EL VS**

FAS584VS-3 **EL VS**

FAS684VS-3 **EL VS**



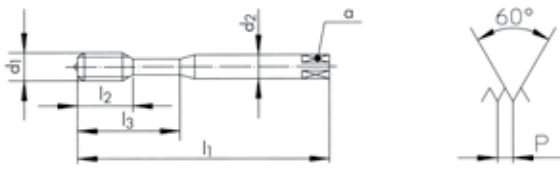







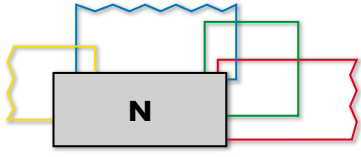
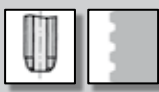
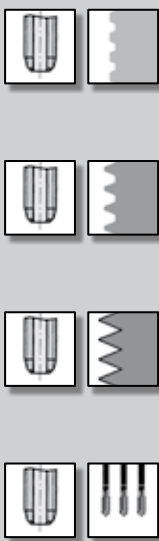

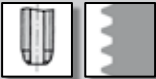
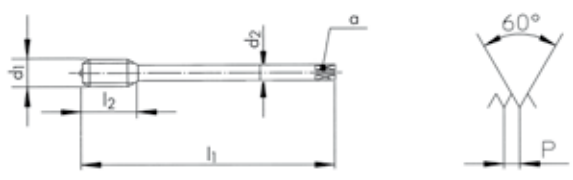



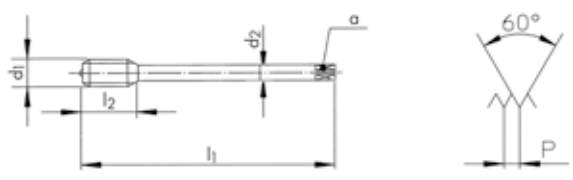





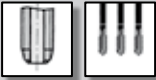

FAS581VS-3	FAS681VS-3	FAS584VS-3	FAS684VS-3
------------	------------	------------	------------

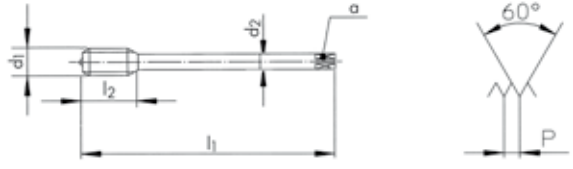

$\varnothing d_1$ M	P mm	l_1 mm	l_2 mm	l_3 mm	d_2 mm	α mm	6HX Tol. → ←
3	0.50	100	12.0	18	3.5	2.7	2.80 +0.03
4	0.70	125	14.0	21	4.5	3.4	3.70 +0.03
5	0.80	140	15.0	25	6.0	4.9	4.65 +0.03
6	1.00	160	17.0	30	6.0	4.9	5.55 +0.05
8	1.25	180	20.0	35	8.0	6.2	7.40 +0.05
10	1.50	200	22.0	39	10.0	8.0	9.30 +0.05
12	1.75	224	24.0		9.0	7.0	11.20 +0.05

ID	ID	ID	ID
172784		172805	
172787		172808	
172790		172811	
172793		172814	
172796		172817	
172799		172820	
	172802		172822

									N1110-1	N1110-2	N1110-3	N1110-S
N1110-1												
N1110-2												
N1110-3												
N1110-S												
Ø d ₁ M	P mm	l ₁ mm	l ₂ mm	l ₃ mm	d ₂ mm	a mm			ID	ID	ID	ID
1	0.25	40	5.5		2.50	2.10	3	0.75	102744	102844	102917	111015
1.2	0.25	40	5.5		2.50	2.10	3	0.95	102746	102846	102919	111017
1.4	0.30	40	7.0		2.50	2.10	3	1.10	102747	102847	102920	111018
1.6	0.35	40	8.0		2.50	2.10	3	1.25	102749	102849	102922	111020
1.7	0.35	40	8.0		2.50	2.10	3	1.35	102750	102850	102923	111021
1.8	0.35	40	8.0		2.50	2.10	3	1.45	102751	102851	102924	111022
2	0.40	45	8.0		2.80	2.10	3	1.60	102759	102854	102934	111028
2.2	0.45	45	9.5		2.80	2.10	3	1.75	102761	102856	102937	111030
2.5	0.45	45	9.5		2.80	2.10	3	2.05	102763	102858	102941	111032
2.6	0.45	45	9.5		2.80	2.10	3	2.15	102765	102860	102944	111034
3	0.50	48	11.0	18	3.15	2.50	3	2.50	102766	102861	102947	111036
3.5	0.60	50	13.0	20	3.55	2.80	3	2.90	102769	102864	102950	111038
4	0.70	53	13.0	21	4.00	3.15	3	3.30	102771	102866	102956	111042
4.5	0.75	53	13.0	21	4.50	3.55	3	3.75	102775	102869	102959	111044
5	0.80	58	16.0	25	5.00	4.00	3	4.20	102776	102870	102965	111047
6	1.00	66	19.0	30	6.30	5.00	3	5.00	102781	102874	102973	111053
7	1.00	66	19.0	30	7.10	5.60	3	6.00	102786	102876	102978	111055
8	1.25	72	22.0	35	8.00	6.30	3	6.80	102788	102878	102986	111059
9	1.25	72	22.0	36	9.00	7.10	3	7.80	102792	102880	102991	111061
10	1.50	80	24.0	39	10.00	8.00	3	8.50	102752	102852	102931	111026























									N1210-1	N1210-2	N1210-3	N1210-S
									N1210-1 			
N1210-2 												
N1210-3  												
N1210-S 												
												
												
$\varnothing d_1$ M	P mm	l_1 mm	l_2 mm	d_2 mm	α mm			ID	ID	ID	ID	
11	1.50	85	22.0	8.0	6.3	3	9.50	103302	103427	103489	111168	
12	1.75	89	24.0	9.0	7.1	3	10.20	103303	103428	103499	111173	
14	2.00	95	24.0	11.2	9.0	3	12.00	103310	103430	103510	111179	
16	2.00	102	32.0	12.5	10.0	3	14.00	103319	103432	103522	111185	
18	2.50	112	30.0	14.0	11.2	3	15.50	103324	103434	103534	111191	
20	2.50	112	37.0	14.0	11.2	3	17.50	103330	103436	103543	111196	
22	2.50	115	32.0	16.0	12.5	3	19.50	103337	103438	103550	125567	
24	3.00	130	45.0	18.0	14.0	4	21.00	103341	103440	103557	111204	
27	3.00	135	45.0	20.0	16.0	4	24.00	103347	103442	103568	111211	
30	3.50	138	48.0	20.0	16.0	4	26.50	103353	103444	103579	111216	
33	3.50	151	51.0	22.4	18.0	4	29.50	103357	103446	103581	111218	
36	4.00	162	57.0	25.0	20.0	4	32.00	103359	103448	103583	111220	

										N1120-4	N1220-4	N1160-3	N1260-3
N1120-4													
N1220-4												NEW	NEW
N1160-3													
N1260-3													
$\varnothing d_1$	P	l_1	l_2	l_3	d_2	a				ID	ID		
M	mm	mm	mm	mm	mm	mm							
3	0.50	48	11.0	18	3.15	2.50	3	2.50		103068			
4	0.70	53	13.0	21	4.00	3.15	3	3.30		103075			
4.5	0.75	53	13.0	21	4.50	3.55	3	3.75		* 103078			
5	0.80	58	16.0	25	5.00	4.00	3	4.20		103082			
6	1.00	66	19.0	30	6.30	5.00	3	5.00		103090			
8	1.25	72	22.0	35	8.00	6.30	3	6.80		103102			
10	1.50	80	24.0	39	10.00	8.00	3	8.50		103060			
11	1.50	85	22.0		8.00	6.30	3	9.50			* 103661		
12	1.75	89	24.0		9.00	7.10	3	10.20			103670		
14	2.00	95	24.0		11.20	9.00	3	12.00			103680		
16	2.00	102	32.0		12.50	10.00	3	14.00			103690		
$\varnothing d_1$	P	l_1	l_2	l_3	d_2	a				ID	ID		
M	mm	mm	mm	mm	mm	mm							
3	0.50	48	5.5	18	3.15	2.50	3	2.50			103177		
4	0.70	53	7.5	21	4.00	3.15	3	3.30			103178		
5	0.80	58	9.0	25	5.00	4.00	3	4.20			103179		
6	1.00	66	11.0	30	6.30	5.00	3	5.00			103180		
8	1.25	72	12.5	35	8.00	6.30	3	6.80			103181		
10	1.50	80	14.0	39	10.00	8.00	3	8.50			103174		
12	1.75	89	14.0		9.00	7.10	3	10.20				103781	
16	2.00	102	18.0		12.50	10.00	3	14.00				103782	

















































285



		N						
Merkmale Characteristics					 V	 TiN	 R15	 R40
								
Lochart Hole type								
			N320-3	N320-4			N350-3	N360-3
DIN lang DIN long	DIN 371		84	84			84	91
ISO kurz ISO short	ISO 529							
DIN lang DIN long	~DIN 2174							
Toleranz Tolerance	ISO 2 6H			84			84	91
Feintoleranz Fine tolerance	ISO 1 4H		84					
Übermass Oversize	ISO 3 6G							91
		N410-3	N420-3	N420-4	N420V-4	N420TN-4	N450-3	N460-3
DIN lang DIN long	DIN 374	85/90	88/89	85/90	85/88	85/86	84	92/93
ISO kurz ISO short	ISO 529							
DIN lang DIN long	~DIN 2174							
Toleranz Tolerance	ISO 2 6H	85/90		85/90	85/88	85/86	84	92/93
Feintoleranz Fine tolerance	ISO 1 4H							
Übermass Oversize	ISO 3 6G							92
Toleranz Tolerance	7H (EN 60423)		88/89					
LH Linksgewinde LH Left hand thread	ISO 2 6H	90		90				

N					Z			
								
								
								
								
N360V-3	N360TN-3	N1110-1	N1110-3	N1110-S	Z320V-3 Z320V-4	Z320VS-4	Z360V-3	Z370VS-3
91	91				94	94	94	94
		106	106	106				
91	91		106	106	94	94	94	94
					94			
N460V-3	N460TN-3	N1210-1	N1210-3	N1210-S	Z420V-4	Z420VS-4	Z460V-3	Z470VS-3
92/93	92				95	95	95	95
		107/108	107/108	107/108				
92/93	92		107/108	107/108	95	95	95	95

	H		S		SA		
Merkmale Characteristics			 VS	 VS			
							
Lochart Hole type							
	H320-4	H350-3	S320VS-4	S360VS-3	SA320-4	SA350-3	SA390-3
<i>DIN lang</i> DIN long	DIN 371						
<i>ISO kurz</i> ISO short	ISO 529						
<i>DIN lang</i> DIN long	~DIN 2174						
<i>Toleranz</i> Tolerance	ISO 2 6H						
<i>Feintoleranz</i> Fine tolerance	ISO 1 4H						
<i>Übermass</i> Oversize	ISO 3 6G						
	H420-4	H450-3	S420VS-4	S460VS-3	SA420-4	SA450-3	
<i>DIN lang</i> DIN long	DIN 374						
<i>ISO kurz</i> ISO short	ISO 529						
<i>DIN lang</i> DIN long	~DIN 2174						
<i>Toleranz</i> Tolerance	ISO 2 6H						
<i>Feintoleranz</i> Fine tolerance	ISO 1 4H						

TL		K	RTS		FPS		FAS	
								
VS	VS		VS	VS	CrN	VS	VS	
		 NEW						
								
TL320VS-4	TL351VS-3	K313TC-3	RTS320VS-4	RTS362VS-3	FPS381CN-3	FPS381VS-3	FAS381VS-3	
100	100	103	102	102				
					104	104	105	
100	100	103	102	102	104	104	105	
100	100							
TL420VS-4	TL451VS-3	K413TC-3	RTS420VS-4	RTS462VS-3	FPS481CN-3	FPS481VS-3	FAS481VS-3	
101	101	103	102	102				
						104	105	
101	101	103	102	102		104	105	
101	101							

MF ISO DIN 13

≤ Ø 2.8 > Ø 2.8

PM

HSSE



HSSE

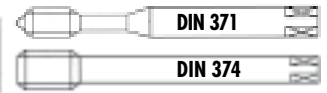

										N320-4		N350-3	N450-3	
N320-4														
N350-3														
N450-3														
Ø d ₁ MF	P mm	l ₁ mm	l ₂ mm	l ₃ mm	d ₂ mm	α mm			ID					
*2	0.25	45	8.0		2.8	2.1	2	1.75	142689					
2.5	0.35	50	10.0		2.8	2.1	3	2.15	142691					
2.6	0.35	50	10.0		2.8	2.1	3	2.25	142692					
3	0.35	56	12.0	18	3.5	2.7	3	2.65	142693					
3.5	0.35	56	13.0	20	4.0	3.0	3	3.15	142694					
Ø d ₁ MF	P mm	l ₁ mm	l ₂ mm	l ₃ mm	d ₂ mm	α mm			ID	ID				
4	0.50	63	14.0	21	4.5	3.4	2	3.50		101586				
5	0.50	70	15.0	25	6.0	4.9	3	4.50		101588				
6	0.75	80	17.0	30	6.0	4.9	3	5.25		101590				
8	1.00	90	20.0		6.0	4.9	3	7.00				102326		
9	0.75	90	20.0		7.0	5.5	3	8.25				102328		
10	1.00	100	22.0		7.0	5.5	3	9.00				102313		
12	1.00	100	24.0		9.0	7.0	3	11.00				* 102315		
12	1.50	100	24.0		9.0	7.0	3	10.50				* 102316		
14	1.50	100	24.0		11.0	9.0	3	12.50				* 102318		
16	1.50	100	26.0		12.0	9.0	3	14.50				* 102320		
18	1.50	110	26.0		14.0	11.0	4	16.50				* 102322		
20	1.50	125	28.0		16.0	12.0	4	18.50				* 102323		
* N320-3										P 0.25				

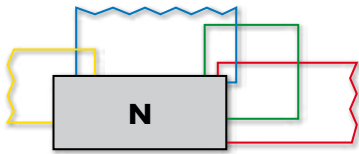

N410-3	N420-4	N420V-4	N420TN-4
--------	--------	---------	----------

N410-3



N420-4





N420V-4



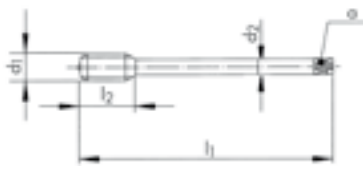





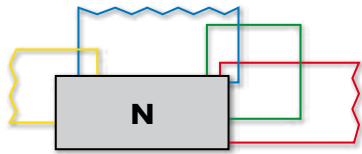

N420TN-4











$\varnothing d_1$ MF	P mm	l_1 mm	l_2 mm	d_2 mm	a mm		
4	0.35	63	14.0	2.8	2.1	3	3.65
4	0.50	63	14.0	2.8	2.1	3	3.50
4.5	0.50	70	15.0	3.5	2.7	3	4.00
5	0.50	70	15.0	3.5	2.7	3	4.50
5	0.75	70	15.0	3.5	2.7	3	4.25
5.5	0.50	80	17.0	4.0	3.0	3	5.00
6	0.50	80	17.0	4.5	3.4	3	5.50
6	0.75	80	17.0	4.5	3.4	3	5.25
7	0.50	80	17.0	5.5	4.3	3	6.50
7	0.75	80	17.0	5.5	4.3	3	6.25
8	0.50	90	20.0	6.0	4.9	3	7.50
8	0.75	90	20.0	6.0	4.9	3	7.25
8	1.00	90	20.0	6.0	4.9	3	7.00
9	0.50	90	20.0	7.0	5.5	3	8.50
9	0.75	90	20.0	7.0	5.5	3	8.25
9	1.00	90	20.0	7.0	5.5	3	8.00
10	0.50	100	22.0	7.0	5.5	3	9.50
10	0.75	100	22.0	7.0	5.5	3	9.25
10	1.00	100	22.0	7.0	5.5	3	9.00
10	1.25	100	22.0	7.0	5.5	3	8.80





ID	ID	ID	ID
	142695		
101923	102145	142715	
	102150		
101941	102167	142716	
	102168		
	142696		
101951	102178	142717	
101952	102179	102281	102249
	102187		
101954	102188		
101955	102190	142718	
101956	102191	102283	
101957	102192	102284	102250
	142697		
	102200		
	102201	143935	
	142698		
101863	102056		
101864	102057	102262	102239
101865	102058	142719	



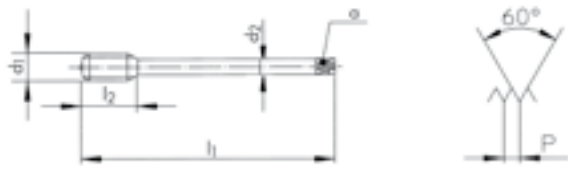

N410-3		
N420-4		
N420V-4	 V	
N420TN-4	 TiN	

N410-3	N420-4	N420V-4	N420TN-4
			
			







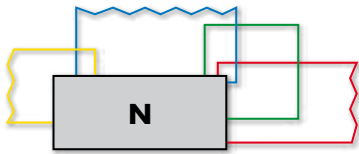

			
ISO 2 6H	ISO 2 6H	ISO 2 6H	ISO 2 6H



$\varnothing d_1$ MF	P mm	l_1 mm	l_2 mm	d_2 mm	a mm			ID	ID	ID	ID
11	0.50	100	19.0	8.0	6.2	3			142699		
11	0.75	100	19.0	8.0	6.2	3			142700		
11	1.00	100	19.0	8.0	6.2	3			142701		
11	1.25	100	19.0	8.0	6.2	3			142702		
12	0.50	100	14.0	9.0	7.0	3			102066		
12	0.75	100	24.0	9.0	7.0	3			142703		
12	1.00	100	24.0	9.0	7.0	3		101867	102067	142345	102241
12	1.25	100	24.0	9.0	7.0	3		101868	102068	142721	
12	1.50	100	24.0	9.0	7.0	3		101869	102069	102264	102242
13	1.00	100	21.0	11.0	9.0	3		158401	142704		
14	0.50	100	14.0	11.0	9.0	3			142705		
14	0.75	100	24.0	11.0	9.0	3			142706		
14	1.00	100	24.0	11.0	9.0	3		101871	102077		
14	1.25	100	24.0	11.0	9.0	3		101872	102078		
14	1.50	100	24.0	11.0	9.0	3		101873	102079	102266	102244
15	1.00	100	26.0	12.0	9.0	3		101875	102085		
15	1.50	100	26.0	12.0	9.0	3		101876	102086		
16	0.75	100	26.0	12.0	9.0	3			142708		
16	1.00	100	26.0	12.0	9.0	*3		101877	102087		
16	1.25	100	26.0	12.0	9.0	*3		101878	102088		
16	1.50	100	26.0	12.0	9.0	*3		101879	102089	102268	102246
17	1.00	100	26.0	12.0	9.0	3			142709		
17	1.50	100	26.0	12.0	9.0	3			142710		
18	0.75	110	26.0	14.0	11.0	4			142711		
18	1.00	110	26.0	14.0	11.0	4		101881	102095		
18	1.50	110	26.0	14.0	11.0	4		101882	102096	102270	
18	2.00	125	33.0	14.0	11.0	3			142712		
19	1.00	110	26.0	14.0	11.0	4			* 142713		



* N410-3 =  4

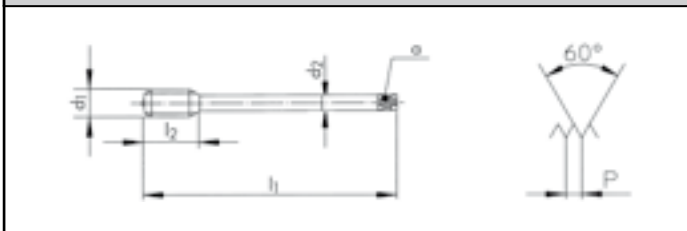







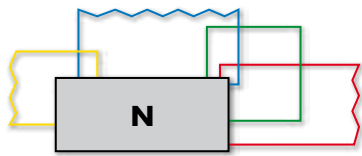

N410-3		
N420-4		
N420V-4	 V	











		
ISO 2 6H	ISO 2 6H	ISO 2 6H





$\varnothing d_1$ MF	P mm	l_1 mm	l_2 mm	d_2 mm	a mm			ID	ID	ID
20	1.00	125	28.0	16.0	12.0	4			102098	
20	1.50	125	28.0	16.0	12.0	4		101884	102099	102272
20	2.00	140	36.0	16.0	12.0	3		105130	102100	
22	1.00	125	28.0	18.0	14.5	4			102104	
22	1.50	125	28.0	18.0	14.5	4		101886	102105	102274
22	2.00	140	36.0	18.0	14.5	3		101887	142714	
24	1.00	140	30.0	18.0	14.5	4			102107	
24	1.50	140	30.0	18.0	14.5	4		101889	102108	102276
24	2.00	140	34.0	18.0	14.5	4		101890	102109	102277
25	1.00	140	30.0	18.0	14.5	4			142722	
25	1.50	140	30.0	18.0	14.5	4		101892	102112	
25	2.00	140	34.0	18.0	14.5	4			142723	
26	1.00	140	30.0	18.0	14.5	4			102113	
26	1.50	140	30.0	18.0	14.5	4		101893	102114	145896
27	1.50	140	34.0	20.0	16.0	4			102115	
27	2.00	140	34.0	20.0	16.0	4		101894	102116	
28	1.00	140	30.0	20.0	16.0	4			142725	
28	1.50	140	30.0	20.0	16.0	4		101896	102118	
28	2.00	140	30.0	20.0	16.0	4		122023		



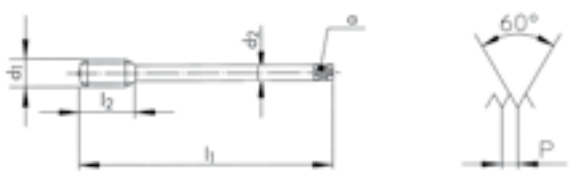

N410-3		
N420-4		
N420V-4	 V	
N420-3		

N410-3	N420-4	N420V-4	N420-3
			
			



			
ISO 2 6H	ISO 2 6H	ISO 2 6H	ISO 3 7H

∅ d ₁ MF	P mm	l ₁ mm	l ₂ mm	d ₂ mm	α mm			ID	ID	ID	ID
30	1.00	150	32.0	22.0	18.0	4	29.00	101898	102121		
30	1.50	150	32.0	22.0	18.0	4	28.50	101899	102122	143978	
30	2.00	150	32.0	22.0	18.0	4	28.00	101900	102123	143766	
32	1.00	150	32.0	22.0	18.0	4	31.00	101902			
32	1.50	150	32.0	22.0	18.0	4	30.50	101903	102126		143812
32	2.00	150	32.0	22.0	18.0	4	30.00	101904	102127		
33	1.50	160	32.0	25.0	20.0	4	31.50	101905	102128		
33	2.00	160	32.0	25.0	20.0	4	31.00	101906	102129		
34	1.00	170	32.0	28.0	22.0	4	33.00	* 101908			
34	1.50	170	32.0	28.0	22.0	4	32.50	101909	* 102131		
35	1.50	170	32.0	28.0	22.0	4	33.50	101910	102132		
35	2.00	170	32.0	28.0	22.0	4	33.00	101911			
36	1.00	170	34.0	28.0	22.0	4	35.00		* 102133		
36	1.50	170	34.0	28.0	22.0	4	34.50	101912	102134		
36	2.00	170	34.0	28.0	22.0	4	34.00	101913	102135		
36	3.00	200	45.0	28.0	22.0	4	33.00	101914	102136		
38	1.00	170	34.0	28.0	22.0	4	37.00	* 101916	* 102138		
38	1.50	170	34.0	28.0	22.0	4	36.50	101917	102139		
38	2.00	170	34.0	28.0	22.0	4	36.00	101918			
39	2.00	170	34.0	32.0	24.0	4	37.00	101920			
39	3.00	200	45.0	32.0	24.0	4	36.00	101921			

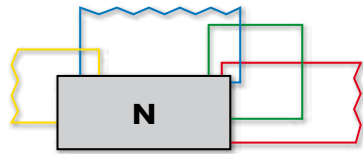

N410-3

N420-4

N420-3

N410-3





N420-4

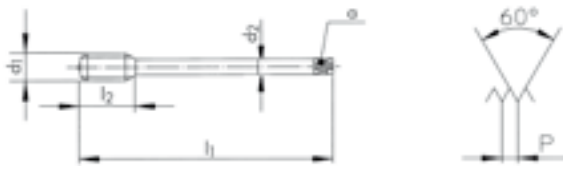

N420-3



MF	∅ d ₁ mm	P mm	l ₁ mm	l ₂ mm	d ₂ mm	a mm		 6H
40	1.00	170	34.0	32.0	24.0	5		39.00
40	1.50	170	34.0	32.0	24.0	5		38.50
40	2.00	170	34.0	32.0	24.0	5		38.00
40	3.00	200	45.0	32.0	24.0	4		37.00
42	1.50	170	34.0	32.0	24.0	5		40.50
42	2.00	170	34.0	32.0	24.0	5		40.00
42	3.00	200	45.0	32.0	24.0	4		39.00
45	1.50	180	34.0	36.0	29.0	5		43.50
45	2.00	180	34.0	36.0	29.0	5		43.00
45	3.00	200	45.0	36.0	29.0	4		42.00
48	1.50	190	36.0	36.0	29.0	5		46.50
48	2.00	190	36.0	36.0	29.0	5		46.00
48	3.00	220	48.0	36.0	29.0	5		45.00
50	1.50	190	36.0	36.0	29.0	5		48.50
50	2.00	190	36.0	36.0	29.0	5		48.00
52	1.50	190	36.0	40.0	32.0	5		50.50
52	2.00	190	36.0	40.0	32.0	5		50.00
52	3.00	220	48.0	40.0	32.0	5		49.00
55	2.00	190	40.0	40.0	32.0	5		53.00
60	2.00	220	42.0	45.0	35.0	5		58.00
63	1.50	220	38.0	45.0	35.0	5		61.50

ID	ID	ID
101925		
101926	102152	143813
101927	102153	
* 101928	* 102154	
101929	102155	
101930	102156	
101931	102157	
101933	102159	
101934		
101935	* 102161	
101937	102163	
101938	102164	
101939	102165	
101943	102176	143814
* 101944	* 102177	
* 101946		
101947		
* 101948		
* 105131		
105132		
		143815

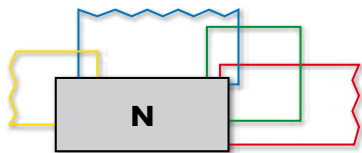

N410-3 LH





N420-4 LH





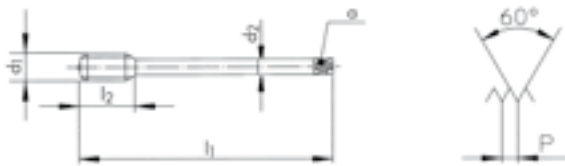





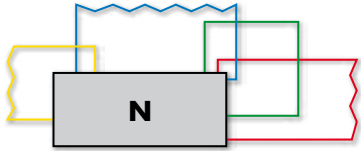

N410-3 LH

N420-4 LH

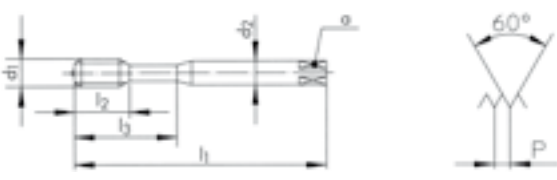

$\varnothing d_1$ MF	P mm	l_1 mm	l_2 mm	d_2 mm	a mm			ID	ID
4	0.50	63	14.0	2.8	2.1	3	3.50	104844	
5	0.50	70	15.0	3.5	2.7	3	4.50	104845	
6	0.50	80	17.0	4.5	3.4	3	5.50	104846	104870
6	0.75	80	17.0	4.5	3.4	3	5.25	104847	105133
7	0.75	80	17.0	5.5	4.3	3	6.25	104848	
8	0.50	90	20.0	6.0	4.9	3	7.50	104849	
8	0.75	90	20.0	6.0	4.9	3	7.25	104850	104871
8	1.00	90	20.0	6.0	4.9	3	7.00	104851	104872
10	0.75	100	22.0	7.0	5.5	3	9.25	104852	
10	1.00	100	22.0	7.0	5.5	3	9.00	104853	104873
10	1.25	100	22.0	7.0	5.5	3	8.80		104874
12	1.00	100	24.0	9.0	7.0	3	11.00	104854	104875
12	1.25	100	24.0	9.0	7.0	3	10.80	104855	104876
12	1.50	100	24.0	9.0	7.0	3	10.50	104856	104877
14	1.00	100	24.0	11.0	9.0	3	13.00	104857	104878
14	1.25	100	24.0	11.0	9.0	3	12.80	104858	
14	1.50	100	24.0	11.0	9.0	3	12.50	104859	104879
16	1.00	100	26.0	12.0	9.0	*3	15.00	104860	104880
16	1.50	100	26.0	12.0	9.0	*3	14.50	104861	104881
18	1.00	110	26.0	14.0	11.0	4	17.00	104862	
18	1.50	110	26.0	14.0	11.0	4	16.50	104863	104882
20	1.00	125	28.0	16.0	12.0	4	19.00	104864	
20	1.50	125	28.0	16.0	12.0	4	18.50	104865	104883
22	1.50	125	28.0	18.0	14.5	4	20.50	104866	104884
24	1.50	140	30.0	18.0	14.5	4	22.50	104867	104885
24	2.00	140	34.0	18.0	14.5	4	22.00	104868	104886
28	1.50	140	30.0	20.0	16.0	4	26.50	105166	
30	1.50	150	32.0	22.0	18.0	4	28.50	105167	105165
30	2.00	150	32.0	22.0	18.0	4	28.00	105168	

* N410-3 LH =  4

										N360-3	N360V-3	N360TN-3	N360-3
													
													
													
													
													
$\varnothing d_1$	P	l_1	l_2	l_3	d_2	α				ID	ID	ID	ID
MF	mm	mm	mm	mm	mm	mm		$\rightarrow \leftarrow$					6H + mm
4	0.50	63	7.5	21	4.5	3.4	3	3.50		101632	101712	111618	101631 0.020
5	0.50	70	9.0	25	6.0	4.9	3	4.50		101641	101714	111617	101640 0.020
6	0.50	80	11.0	30	6.0	4.9	3	5.50		101648	143990		
6	0.75	80	11.0	30	6.0	4.9	3	5.25		101650	101716	101702	101649 0.022
8	0.75	90	12.5	35	8.0	6.2	3	7.25		101658	101719		101657 0.022
8	1.00	90	12.5	35	8.0	6.2	3	7.00		101660	101720	101704	101659 0.026
10	0.75	100	14.0	39	10.0	8.0	3	9.25		101606	144401		
10	1.00	100	14.0	39	10.0	8.0	3	9.00		101608	101706	101695	101607 0.026
10	1.25	100	14.0	39	10.0	8.0	3	8.80		101609	105134	110965	

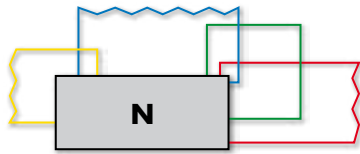

N460-3



N460V-3



N460TN-3



N460-3

N460V-3

N460TN-3

N460-3

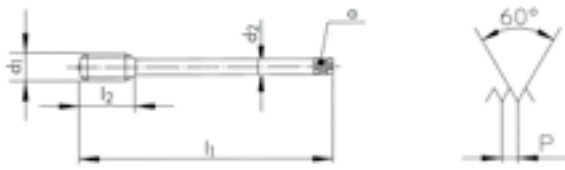



ISO 2
6H

ISO 2
6H

ISO 2
6H

ISO 3
6G

$\varnothing d_1$ MF	P mm	l_1 mm	l_2 mm	d_2 mm	a mm		$\pm 6H$ 	ID	ID	ID	ID $6H$ + mm
12	1.00	100	14.0	9.0	7.0	3	11.00	102353	102462	102447	102352 0.026
12	1.25	100	14.0	9.0	7.0	3	10.80	102354	102463	144202	
12	1.50	100	14.0	9.0	7.0	3	10.50	102356	102464	102448	102355 0.032
13	1.00	100	14.0	11.0	9.0	3	12.00	102364			
14	1.00	100	14.0	11.0	9.0	3	13.00	102365	102466		
14	1.50	100	14.0	11.0	9.0	3	12.50	102367	102467	102450	102366 0.032
15	1.00	100	14.0	12.0	9.0	3	14.00	102370			
15	1.50	100	18.0	12.0	9.0	3	13.50	102371			
16	1.00	100	14.0	12.0	9.0	4	15.00	102372	102469		
16	1.50	100	14.0	12.0	9.0	4	14.50	102374	102470	102452	102373 0.032
18	1.00	110	18.0	14.0	11.0	4	17.00	102380	143926		
18	1.50	110	18.0	14.0	11.0	4	16.50	102382	102472		102381 0.032
20	1.00	125	20.0	16.0	12.0	4	19.00	102384	146377		
20	1.50	125	20.0	16.0	12.0	4	18.50	102386	102474		
20	2.00	140	24.0	16.0	12.0	4	18.00	102387	143566		
22	1.00	125	20.0	18.0	14.5	4	21.00	102392	147702		
22	1.50	125	20.0	18.0	14.5	4	20.50	102393	102476		
24	1.50	140	22.0	18.0	14.5	4	22.50	102396	102478		
24	2.00	140	22.0	18.0	14.5	4	22.00	102397	102479		
25	1.50	140	22.0	18.0	14.5	4	23.50	102399	143810		
26	1.50	140	22.0	18.0	14.5	4	24.50	102400	143952		
27	1.50	140	22.0	20.0	16.0	4	25.50	102401	143965		
27	2.00	140	22.0	20.0	16.0	4	25.00	102402	144201		
28	1.50	140	22.0	20.0	16.0	4	26.50	102403	144997		

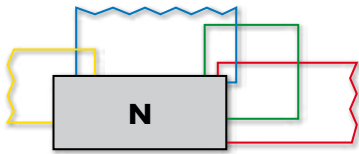

N460-3

N460V-3

N460-3



N460V-3

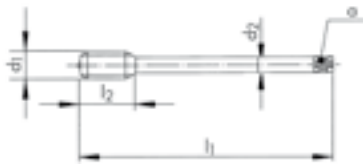

ISO 2
6H

ISO 2
6H

MF	$\varnothing d_1$ mm	P mm	l_1 mm	l_2 mm	d_2 mm	α mm		$\pm 6H$ mm
30	1.50	150	24.0	22.0	18.0	4	28.50	
30	2.00	150	24.0	22.0	18.0	4	28.00	
32	1.50	150	24.0	22.0	18.0	4	30.50	
33	2.00	160	26.0	25.0	20.0	4	31.00	
33	3.00	180	33.0	25.0	20.0	4	30.00	
35	1.50	170	24.0	28.0	22.0	5	33.50	
36	1.50	170	24.0	28.0	22.0	5	34.50	
36	2.00	170	28.0	28.0	22.0	5	34.00	
36	3.00	200	36.0	28.0	22.0	4	33.00	
39	3.00	200	40.0	32.0	24.0	5	36.00	
42	3.00	200	40.0	32.0	24.0	5	39.00	

ID

ID

102404

142524

102405

142581

102406

143605

102407

147604

175437

150448

102408

146846

102409

143824

175436

164870

115072

150453

174995

122669

174996

150436

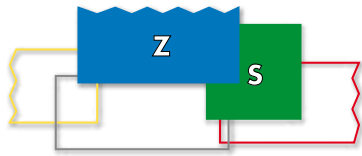

Z320V-4

Z320VS-4

Z360V-3

Z370VS-3



NEW



PM



ISO 2
6H

ISO 2
6H

ISO 2
6H

6HX

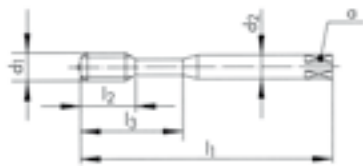

Z320V-4



Z320VS-4



Z360V-3



Z370VS-3



∅ d ₁ MF	P mm	l ₁ mm	l ₂ mm	l ₃ mm	d ₂ mm	a mm		
*2	0.20	45	8.0		2.8	2.1	2	1.80
*2	0.25	45	8.0		2.8	2.1	2	1.75
*2.2	0.25	45	9.0		2.8	2.1	2	1.95
2.5	0.20	50	10.0		2.8	2.1	3	2.30
2.5	0.25	50	10.0		2.8	2.1	3	2.25
3	0.35	56	12.0	18	3.5	2.7	3	2.65
6	0.75	80	17.0	30	6.0	4.9	3	5.25
8	1.00	90	20.0	35	8.0	6.2	3	7.00
10	1.00	100	22.0	39	10.0	8.0	3	9.00

B 4 x P	B 4 x P	C 2.5 x P	C 2.5 x P
ISO 2 6H	ISO 2 6H	ISO 2 6H	6HX
ID	ID		
146487			
114715			
115462			
115578			
115887			
115468			
142726			
142727	124289		
142728	120060		

∅ d ₁ MF	P mm	l ₁ mm	l ₂ mm	l ₃ mm	d ₂ mm	a mm		
4	0.50	63	7.5	21	4.5	3.4	3	3.50
5	0.50	70	9.0	25	6.0	4.9	3	4.50
6	0.75	80	11.0	30	6.0	4.9	3	5.25
8	1.00	90	12.5	35	8.0	6.2	3	7.00
10	1.00	100	14.0	39	10.0	8.0	3	9.00

ID
104675
104676
104677
104678
104674

∅ d ₁ MF	P mm	l ₁ mm	l ₂ mm	l ₃ mm	d ₂ h ₆ mm	a mm		
6	0.75	80	11.0	30	6.0	4.9	3	5.25
8	1.00	90	12.5	35	8.0	6.2	3	7.00
10	1.00	100	14.0	39	10.0	8.0	3	9.00

ID
166117
166118
166119

* Z320V-3



P ≤ 0.25

ISO 1
4H

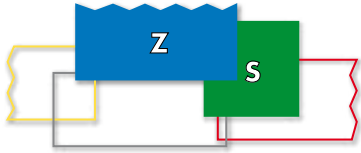

Z420V-4 Z420VS-4 Z460V-3 Z470VS-3



NEW



PM



ISO 2 6H ISO 2 6H ISO 2 6H 6HX

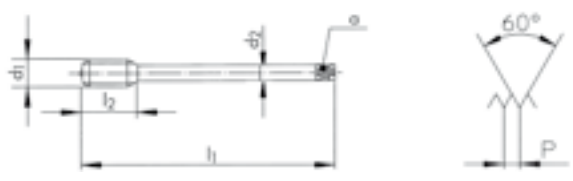

Z420V-4

Z420VS-4

Z460V-3

Z470VS-3

∅ d ₁ MF	P mm	l ₁ mm	l ₂ mm	d ₂ mm	a mm		
12	1.00	100	24.0	9.0	7.0	3	11.00
12	1.50	100	24.0	9.0	7.0	3	10.50
14	1.50	100	24.0	11.0	9.0	3	12.50
16	1.50	100	26.0	12.0	9.0	3	14.50

ID	ID
142729	
142730	120421
142731	120688
142732	120878

∅ d ₁ MF	P mm	l ₁ mm	l ₂ mm	d ₂ mm	a mm		
12	1.00	100	14.0	9.0	7.0	3	11.00
12	1.50	100	14.0	9.0	7.0	3	10.50
14	1.50	100	14.0	11.0	9.0	3	12.50
16	1.50	100	14.0	12.0	9.0	4	14.50
18	1.50	110	18.0	14.0	11.0	4	16.50
20	1.50	125	20.0	16.0	12.0	4	18.50
22	1.50	125	20.0	18.0	14.5	4	20.50
24	1.50	140	22.0	18.0	14.5	4	22.50
24	2.00	140	22.0	18.0	14.5	4	22.00

ID
104729
104730
104731
104732
104733
104734
104735
104736
104737



∅ d ₁ MF	P mm	l ₁ mm	l ₂ mm	d ₂ h ₆ mm	a mm		
12	1.50	110	14.0	*10.0	*8.0	4	10.50
14	1.50	110	14.0	*12.0	*9.0	4	12.50
16	1.50	110	18.0	12.0	9.0	4	14.50

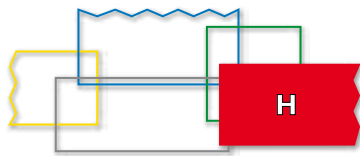

ID
166120
166121
166122

* Norme DC / * DC Norm / * Norma DC





H320-4	H420-4		
---------------	---------------	--	--

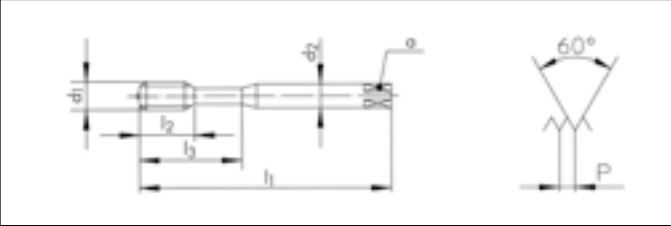

H320-4  

H420-4  



ISO 2 6H **ISO 2 6H**

$\varnothing d_1$ MF	P mm	l_1 mm	l_2 mm	l_3 mm	d_2 mm	a mm			ID	ID
6	0.75	80	17.0	30	6.0	4.9	3	5.25	101214	
8	0.75	90	20.0	35	8.0	6.2	3	7.25	101216	
8	1.00	90	20.0	35	8.0	6.2	3	7.00	101217	
10	1.00	100	22.0	39	10.0	8.0	3	9.00	101204	
12	1.25	100	24.0		9.0	7.0	4	10.80		101273
12	1.50	100	24.0		9.0	7.0	4	10.50		101274
14	1.50	100	24.0		11.0	9.0	4	12.50		101276
16	1.50	100	26.0		12.0	9.0	4	14.50		101278
20	1.50	125	28.0		16.0	12.0	4	18.50		101282
24	2.00	140	34.0		18.0	14.5	4	22.00		101285

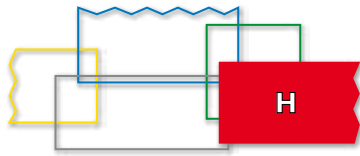

H350-3

H450-3

H350-3



H450-3

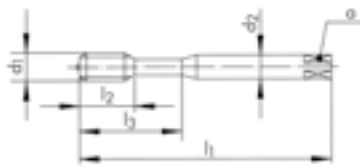

Ø d ₁ MF	P mm	l ₁ mm	l ₂ mm	l ₃ mm	d ₂ mm	a mm		
6	0.75	80	11.0	30	6.0	4.9	3	5.25
8	0.75	90	12.5	35	8.0	6.2	3	7.25
8	1.00	90	12.5	35	8.0	6.2	3	7.00
10	1.00	100	14.0	39	10.0	8.0	3	9.00
12	1.00	100	14.0		9.0	7.0	4	11.00
12	1.50	100	14.0		9.0	7.0	4	10.50
14	1.50	100	14.0		11.0	9.0	4	12.50
16	1.50	100	14.0		12.0	9.0	4	14.50
18	1.50	110	18.0		14.0	11.0	4	16.50
20	1.50	125	20.0		16.0	12.0	4	18.50
22	1.50	125	20.0		18.0	14.5	4	20.50
24	1.50	140	22.0		18.0	14.5	4	22.50
24	2.00	140	22.0		18.0	14.5	4	22.00
27	2.00	140	22.0		20.0	16.0	4	25.00
30	1.50	150	24.0		22.0	18.0	4	28.50
30	2.00	150	24.0		22.0	18.0	4	28.00

ID

ID

101249

101252

101253

101235

101302

101303

101306

101308

101310

101312

101314

101316

101317

101319

101321

101322

										S320VS-4	S420VS-4	S360VS-3	S460VS-3
S320VS-4		VS											
S420VS-4		VS											
S360VS-3		VS											
S460VS-3		VS											
										6HX	6HX	6HX	6HX
$\varnothing d_1$	P	l_1	l_2	l_3	d_2	a				ID	ID		
MF	mm	mm	mm	mm	mm	mm							
6	0.75	80	17.0	30	6.0	4.9	3	5.25		* 123690			
8	1.00	90	20.0	35	8.0	6.2	3	7.00		124288			
10	1.00	100	22.0	39	10.0	8.0	3	9.00		120059			
12	1.50	100	24.0		9.0	7.0	4	10.50			120420		
14	1.50	100	24.0		11.0	9.0	4	12.50			120687		
16	1.50	100	26.0		12.0	9.0	4	14.50			120877		
$\varnothing d_1$	P	l_1	l_2	l_3	d_2	a					ID	ID	
MF	mm	mm	mm	mm	mm	mm							
8	1.00	90	12.5	35	8.0	6.2	3	7.00			111528		
10	1.00	100	14.0	39	10.0	8.0	3	9.00			111529		
12	1.50	100	14.0		9.0	7.0	4	10.50				111540	
14	1.50	100	14.0		11.0	9.0	4	12.50				111541	
16	1.50	100	14.0		12.0	9.0	4	14.50				111542	

aero

SA390-3

SA390-3

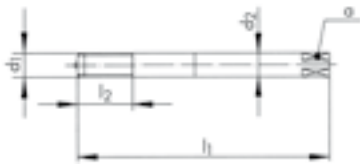

$\varnothing d_1$ MF	P mm	l_1 mm	l_2 mm	d_2 mm	α mm		
8	1.00	90	25.0	8.0	6.2	3	7.00
10	1.00	100	30.0	10.0	8.0	3	9.00
10	1.25	100	30.0	10.0	8.0	3	8.80
12	1.00	110	35.0	12.0	9.0	4	11.00
12	1.50	110	35.0	12.0	9.0	4	10.50
14	1.50	110	40.0	16.0	12.0	4	12.50

ID

* 149735

* 149751

* 149753

* 149769

* 149773

* 149790

MF

aero

										SA320-4	SA350-3	TL320VS-4	TL351VS-3
<p>SA320-4 </p> <p>SA350-3 </p>													
<p>TL320VS-4 VS </p> <p>TL351VS-3 VS </p>													
$\varnothing d_1$	P	l_1	l_2	l_3	d_2	a				ID	ID	ID	ID
MF	mm	mm	mm	mm	mm	mm							
4	0.50	63	14.0		4.5	3.4	3	3.50			* 149079	* 152032	152033
5	0.50	70	15.0		6.0	4.9	3	4.50	* 149142	149144	* 152048	* 152048	152049
6	0.50	80	15.0	23	6.0	4.9	3	5.50	* 149193		* 152058	* 152058	152059
8	1.00	90	18.0	29	8.0	6.2	3	7.00	149304	149306	* 152079	* 152079	152080
10	1.00	100	20.0	33	10.0	8.0	3	9.00	149362	149364	* 152092	* 152092	152093
$\varnothing d_1$	P	l_1	l_2	l_3	d_2	a				ID	ID	ID	ID
MF	mm	mm	mm	mm	mm	mm							
4	0.50	63	14.0		4.5	3.4	3	3.50	149081	149083	* 152034	* 152034	152035
5	0.50	70	15.0		6.0	4.9	3	4.50	149146	149148	* 152050	* 152050	152051
6	0.50	80	15.0	23	6.0	4.9	3	5.50		* 149199	* 152060	* 152060	152061
8	1.00	90	18.0	29	8.0	6.2	3	7.00	149308	149310			148019
10	1.00	100	20.0	33	10.0	8.0	3	9.00	149366	149368	* 152094	* 152094	148026

aero

									SA420-4	SA450-3	TL420VS-4	TL451VS-3																																																																																											
SA420-4 SA450-3																																																																																																							
TL420VS-4 TL451VS-3																																																																																																							
<table border="1"> <thead> <tr> <th>$\varnothing d_1$</th> <th>P</th> <th>l_1</th> <th>l_2</th> <th>d_2</th> <th>α</th> <th></th> <th></th> <th></th> <th>ID</th> <th>ID</th> <th>ID</th> <th>ID</th> </tr> <tr> <th>MF</th> <th>mm</th> <th>mm</th> <th>mm</th> <th>mm</th> <th>mm</th> <th></th> <th></th> <th></th> <th></th> <th></th> <th></th> <th></th> </tr> </thead> <tbody> <tr> <td>12</td> <td>1.00</td> <td>100</td> <td>19.0</td> <td>9.0</td> <td>7.0</td> <td>4</td> <td></td> <td>11.00</td> <td>* 152209</td> <td></td> <td>* 152218</td> <td></td> </tr> <tr> <td>12</td> <td>1.50</td> <td>100</td> <td>24.0</td> <td>9.0</td> <td>7.0</td> <td>4</td> <td></td> <td>10.50</td> <td>* 152208</td> <td>* 152213</td> <td></td> <td></td> </tr> <tr> <td>14</td> <td>1.50</td> <td>100</td> <td>24.0</td> <td>11.0</td> <td>9.0</td> <td>4</td> <td></td> <td>12.50</td> <td>* 152210</td> <td>* 152214</td> <td></td> <td>* 152224</td> </tr> <tr> <td>16</td> <td>1.50</td> <td>100</td> <td>26.0</td> <td>12.0</td> <td>9.0</td> <td>4</td> <td></td> <td>14.50</td> <td>* 152212</td> <td>* 152216</td> <td></td> <td>* 152226</td> </tr> </tbody> </table>									$\varnothing d_1$	P	l_1	l_2	d_2	α				ID	ID	ID	ID	MF	mm	mm	mm	mm	mm								12	1.00	100	19.0	9.0	7.0	4		11.00	* 152209		* 152218		12	1.50	100	24.0	9.0	7.0	4		10.50	* 152208	* 152213			14	1.50	100	24.0	11.0	9.0	4		12.50	* 152210	* 152214		* 152224	16	1.50	100	26.0	12.0	9.0	4		14.50	* 152212	* 152216		* 152226																	
$\varnothing d_1$	P	l_1	l_2	d_2	α				ID	ID	ID	ID																																																																																											
MF	mm	mm	mm	mm	mm																																																																																																		
12	1.00	100	19.0	9.0	7.0	4		11.00	* 152209		* 152218																																																																																												
12	1.50	100	24.0	9.0	7.0	4		10.50	* 152208	* 152213																																																																																													
14	1.50	100	24.0	11.0	9.0	4		12.50	* 152210	* 152214		* 152224																																																																																											
16	1.50	100	26.0	12.0	9.0	4		14.50	* 152212	* 152216		* 152226																																																																																											
<table border="1"> <thead> <tr> <th>$\varnothing d_1$</th> <th>P</th> <th>l_1</th> <th>l_2</th> <th>d_2</th> <th>α</th> <th></th> <th></th> <th></th> <th>ID</th> <th>ID</th> <th>ID</th> <th>ID</th> </tr> <tr> <th>MF</th> <th>mm</th> <th>mm</th> <th>mm</th> <th>mm</th> <th>mm</th> <th></th> <th></th> <th></th> <th></th> <th></th> <th></th> <th></th> </tr> </thead> <tbody> <tr> <td>12</td> <td>1.00</td> <td>100</td> <td>19.0</td> <td>9.0</td> <td>7.0</td> <td>4</td> <td></td> <td>11.00</td> <td>* 152228</td> <td>* 148967</td> <td>* 152237</td> <td>* 152242</td> </tr> <tr> <td>12</td> <td>1.50</td> <td>100</td> <td>24.0</td> <td>9.0</td> <td>7.0</td> <td>4</td> <td></td> <td>10.50</td> <td>* 152227</td> <td>* 152232</td> <td></td> <td>* 152241</td> </tr> <tr> <td>14</td> <td>1.50</td> <td>100</td> <td>24.0</td> <td>11.0</td> <td>9.0</td> <td>4</td> <td></td> <td>12.50</td> <td>* 152229</td> <td>* 152233</td> <td>* 152238</td> <td>* 152243</td> </tr> <tr> <td>16</td> <td>1.00</td> <td>100</td> <td>23.0</td> <td>12.0</td> <td>9.0</td> <td>4</td> <td></td> <td>15.00</td> <td></td> <td></td> <td>* 152239</td> <td>* 152244</td> </tr> <tr> <td>16</td> <td>1.50</td> <td>100</td> <td>26.0</td> <td>12.0</td> <td>9.0</td> <td>4</td> <td></td> <td>14.50</td> <td></td> <td>* 152235</td> <td>* 152240</td> <td>* 152245</td> </tr> </tbody> </table>									$\varnothing d_1$	P	l_1	l_2	d_2	α				ID	ID	ID	ID	MF	mm	mm	mm	mm	mm								12	1.00	100	19.0	9.0	7.0	4		11.00	* 152228	* 148967	* 152237	* 152242	12	1.50	100	24.0	9.0	7.0	4		10.50	* 152227	* 152232		* 152241	14	1.50	100	24.0	11.0	9.0	4		12.50	* 152229	* 152233	* 152238	* 152243	16	1.00	100	23.0	12.0	9.0	4		15.00			* 152239	* 152244	16	1.50	100	26.0	12.0	9.0	4		14.50		* 152235	* 152240	* 152245				
$\varnothing d_1$	P	l_1	l_2	d_2	α				ID	ID	ID	ID																																																																																											
MF	mm	mm	mm	mm	mm																																																																																																		
12	1.00	100	19.0	9.0	7.0	4		11.00	* 152228	* 148967	* 152237	* 152242																																																																																											
12	1.50	100	24.0	9.0	7.0	4		10.50	* 152227	* 152232		* 152241																																																																																											
14	1.50	100	24.0	11.0	9.0	4		12.50	* 152229	* 152233	* 152238	* 152243																																																																																											
16	1.00	100	23.0	12.0	9.0	4		15.00			* 152239	* 152244																																																																																											
16	1.50	100	26.0	12.0	9.0	4		14.50		* 152235	* 152240	* 152245																																																																																											

MF



Uniquement pour taraudage synchrone
Nur für Synchrobearbeitung
Only for rigid tapping
Solo per maschiatura sincrona
Solo para rosado sincronizado

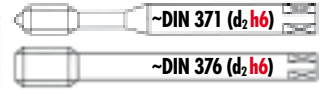

RTS Rigid Tapping Synchro

RTS320VS-4



11	12	13	14
15	21	22	31
32	61	63	72
73	74		

RTS420VS-4



RTS362VS-3



11	12	13	14
15	21	22	31
32	61	63	72
73	74		

RTS462VS-3



RTS320VS-4

RTS420VS-4

RTS362VS-3

RTS462VS-3



6HX

6HX

6HX

6HX

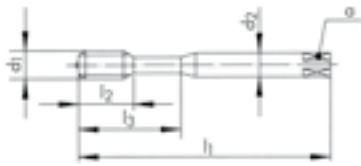

∅ d ₁ MF	P mm	l ₁ mm	l ₂ mm	l ₃ mm	d ₂ h6 mm	a mm		
8	1.00	90	12.5	35	8.0	6.2	3	7.00
10	1.00	100	14.0	39	10.0	8.0	3	9.00
12	1.50	110	14.0		*10.0	*8.0	3	10.50
14	1.50	110	14.0		*12.0	*9.0	3	12.50
16	1.50	110	18.0		12.0	9.0	3	14.50

* Norme DC / * DC Norm / * Norma DC

∅ d ₁ MF	P mm	l ₁ mm	l ₂ mm	l ₃ mm	d ₂ h6 mm	a mm		
8	1.00	90	12.5	35	8.0	6.2	3	7.00
10	1.00	100	14.0	39	10.0	8.0	3	9.00
12	1.50	110	14.0		*10.0	*8.0	3	10.50
14	1.50	110	14.0		*12.0	*9.0	3	12.50
16	1.50	110	18.0		12.0	9.0	3	14.50

* Norme DC / * DC Norm / * Norma DC



sur demande
auf Anfrage
on request
su richiesta
sobre pedido

K										K313TC-3	K413TC-3														
<div style="display: flex; justify-content: space-between;"> <div style="width: 45%;"> <p>K313TC-3</p> <p>>20 bar</p> </div> <div style="width: 45%;"> <table border="1"> <tr><td>11</td><td>12</td><td>13</td><td>14</td></tr> <tr><td>15</td><td>31</td><td>32</td><td>62</td></tr> <tr><td>63</td><td>74</td><td></td><td></td></tr> </table> </div> </div>										11	12	13	14	15	31	32	62	63	74						
11	12	13	14																						
15	31	32	62																						
63	74																								
<div style="display: flex; justify-content: space-between;"> <div style="width: 45%;"> <p>K413TC-3</p> <p>>20 bar</p> </div> <div style="width: 45%;"> <table border="1"> <tr><td>11</td><td>12</td><td>13</td><td>14</td></tr> <tr><td>15</td><td>31</td><td>32</td><td>62</td></tr> <tr><td>63</td><td>74</td><td></td><td></td></tr> </table> </div> </div>										11	12	13	14	15	31	32	62	63	74			NEW	NEW		
11	12	13	14																						
15	31	32	62																						
63	74																								
										6HX	6HX														
$\varnothing d_1$	P	l_1	l_2	l_3	l_6	d_2	a			ID	ID														
MF	mm	mm	mm	mm	mm	mm	mm																		
10	1.00	100	22.0	39	37	10.0	8.0	3	9.00	175729															
12	1.00	110	24.0		42	9.0	7.0	3	11.00		175731														
12	1.25	110	24.0		42	9.0	7.0	3	10.80		175733														
12	1.50	110	24.0		42	9.0	7.0	3	10.50		175735														
14	1.50	110	28.0		49	11.0	9.0	3	12.50		175737														
16	1.50	110	30.0		56	12.0	9.0	3	14.50		175739														
20	1.50	140	36.0		70	16.0	12.0	5	18.50		171205														

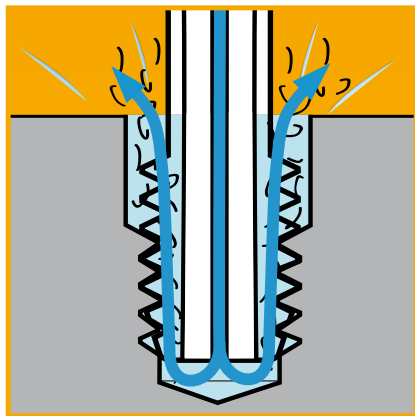

FPS FORMING

FPS381CN-3



FPS381VS-3



FPS481VS-3



FPS381CN-3

FPS381VS-3

FPS481VS-3

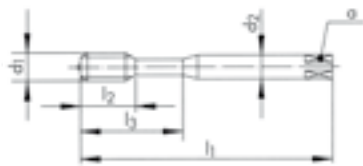

$\varnothing d_1$ MF	P mm	l_1 mm	l_2 mm	l_3 mm	d_2 mm	a mm	6HX → ← Tol.
4	0.50	63	14.0	21	4.5	3.4	3.80 + 0.03
5	0.50	70	15.0	25	6.0	4.9	4.80 + 0.03
6	0.50	80	17.0	30	6.0	4.9	5.80 + 0.03
6	0.75	80	17.0	30	6.0	4.9	5.65 + 0.03
8	0.75	90	20.0	35	8.0	6.2	7.65 + 0.03
8	1.00	90	20.0	35	8.0	6.2	7.55 + 0.05
10	1.00	100	22.0	39	10.0	8.0	9.55 + 0.05
12	1.00	100	19.0		9.0	7.0	11.55 + 0.05
14	1.50	100	24.0		11.0	9.0	13.30 + 0.05
16	1.50	100	26.0		12.0	9.0	15.30 + 0.05

ID

ID

ID

166631

166639

166699

166648

166649

166701

166702

166658

166659

166668

166669

166674

166679

166684

FAS FORMING

FAS381VS-3



VS

12	13	14	15
21	22	23	24
41	51	61	63

FAS481VS-3



VS

12	13	14	15
21	22	23	24
41	51	61	63

FAS381VS-3

FAS481VS-3

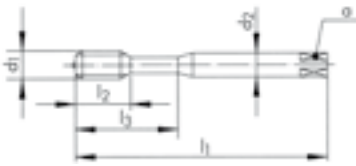

6HX

6HX

$\varnothing d_1$ MF	P mm	l_1 mm	l_2 mm	l_3 mm	d_2 mm	a mm	6HX → ←	Tol.
4	0.50	63	14.0	21	4.5	3.4	3.80	+ 0.03
5	0.50	70	15.0	25	6.0	4.9	4.80	+ 0.03
6	0.50	80	17.0	30	6.0	4.9	5.80	+ 0.03
6	0.75	80	17.0	30	6.0	4.9	5.65	+ 0.03
8	0.75	90	20.0	35	8.0	6.2	7.65	+ 0.03
8	1.00	90	20.0	35	8.0	6.2	7.55	+ 0.05
10	1.00	100	22.0	39	10.0	8.0	9.55	+ 0.05
12	1.00	100	19.0		9.0	7.0	11.55	+ 0.05
14	1.50	100	24.0		11.0	9.0	13.30	+ 0.05
16	1.50	100	26.0		12.0	9.0	15.30	+ 0.05

ID

ID

166625

166633

166698

166642

166700

166652

166662

166672

166677

166682

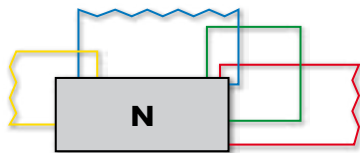
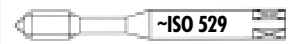

N1110-1

N1110-3

N1110-S

N1110-1

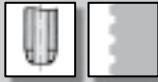

N1110-3

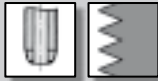

N1110-S

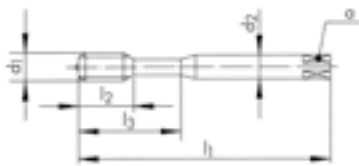

Ø d ₁ MF	P mm	l ₁ mm	l ₂ mm	l ₃ mm	d ₂ mm	a mm		
2	0.25	45	8.0		2.80	2.10	3	1.75
2.2	0.25	45	9.5		2.80	2.10	3	1.95
2.3	0.25	45	9.5		2.80	2.10	3	2.05
2.5	0.35	45	9.5		2.80	2.10	3	2.15
3	0.35	48	11.0	18	3.15	2.50	3	2.65
3.5	0.35	50	13.0	20	3.55	2.80	3	3.15
4	0.35	53	13.0	21	4.00	3.15	3	3.65
4	0.50	53	13.0	21	4.00	3.15	3	3.50
4.5	0.50	53	13.0	21	4.50	3.55	3	4.00
5	0.35	58	16.0	25	5.00	4.00	3	4.65
5	0.50	58	16.0	25	5.00	4.00	3	4.50
5	0.75	58	16.0	25	5.00	4.00	3	4.25
5.5	0.50	62	17.0	26	5.60	4.50	3	5.00
6	0.50	66	19.0	30	6.30	5.00	3	5.50
6	0.75	66	19.0	30	6.30	5.00	3	5.25
7	0.50	66	19.0	30	7.10	5.60	3	6.50
8	0.75	72	22.0	35	8.00	6.30	3	7.25
8	1.00	72	22.0	35	8.00	6.30	3	7.00
9	0.50	72	22.0	36	9.00	7.10	3	8.50
9	0.75	72	22.0	36	9.00	7.10	3	8.25
9	1.00	72	22.0	36	9.00	7.10	3	8.00
10	0.50	80	24.0	39	10.00	8.00	3	9.50
10	1.00	80	24.0	39	10.00	8.00	3	9.00
10	1.25	80	24.0	39	10.00	8.00	3	8.80

ID

ID

ID

102933

102936

* 102938

102940

102945

102949

102952

102773

102953

111040

102958

102960

102778

102961

111045

102963

102967

102783

102969

111050

102784

102971

111051

102975

102790

102982

111057

102791

102984

111058

102988

102989

102990

102925

102756

102928

111024

102758

102930

111025

P 0.25

ISO 1
4H

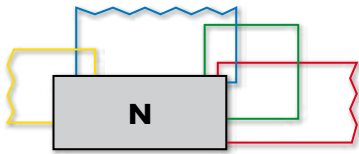

N1210-1

N1210-3

N1210-S

N1210-1

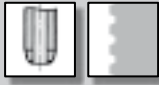

N1210-3



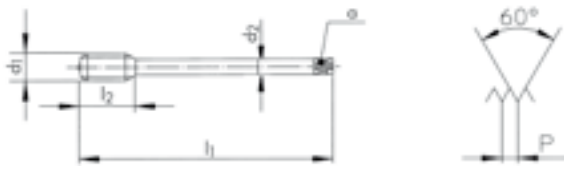

N1210-S



ISO 2
6H

ISO 2
6H

MF	$\varnothing d_1$ mm	P mm	l_1 mm	l_2 mm	d_2 mm	a mm		
11	0.50	85	22.0	8.0	6.3	3	10.50	
11	0.75	85	22.0	8.0	6.3	3	10.25	
11	1.00	85	22.0	8.0	6.3	3	10.00	
11	1.25	85	22.0	8.0	6.3	3	9.80	
12	0.50	89	24.0	9.0	7.1	3	11.50	
12	0.75	89	24.0	9.0	7.1	3	11.25	
12	1.00	89	24.0	9.0	7.1	3	11.00	
12	1.25	89	24.0	9.0	7.1	3	10.80	
12	1.50	89	24.0	9.0	7.1	3	10.50	
14	0.50	95	24.0	11.2	9.0	3	13.50	
14	0.75	95	24.0	11.2	9.0	3	13.25	
14	1.00	95	24.0	11.2	9.0	3	13.00	
14	1.25	95	24.0	11.2	9.0	3	12.80	
14	1.50	95	24.0	11.2	9.0	3	12.50	
15	0.75	90	23.0	11.2	9.0	3	14.25	
15	1.00	90	23.0	11.2	9.0	3	14.00	
16	0.50	102	32.0	12.5	10.0	4	15.50	
16	0.75	102	32.0	12.5	10.0	4	15.25	
16	1.00	102	32.0	12.5	10.0	4	15.00	
16	1.50	102	32.0	12.5	10.0	4	14.50	
17	1.00	95	23.0	12.5	10.0	4	16.00	
18	0.75	112	30.0	14.0	11.2	4	17.25	
18	1.00	112	30.0	14.0	11.2	4	17.00	
18	1.50	112	30.0	14.0	11.2	4	16.50	
18	2.00	112	30.0	14.0	11.2	3	16.00	
19	1.00	112	33.0	14.0	11.2	4	18.00	

ID

ID

ID

103485

103486

103487

103488

103490

103491

103305

103493

111169

103307

103495

111171

103308

103497

111172

103502

103503

103312

103504

111175

103314

103506

111177

103315

103508

111178

103512

103513

103515

103516

103321

103517

111183

103322

103520

111184

103525

103527

103326

103528

111187

103327

103531

111188

103533

103536

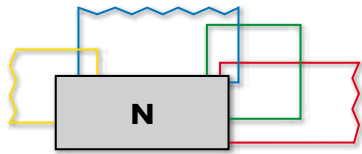

N1210-1

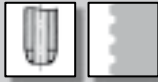

N1210-3



N1210-S



N1210-1

N1210-3



N1210-S

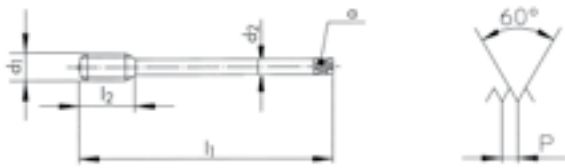

ISO 2
6H

ISO 2
6H







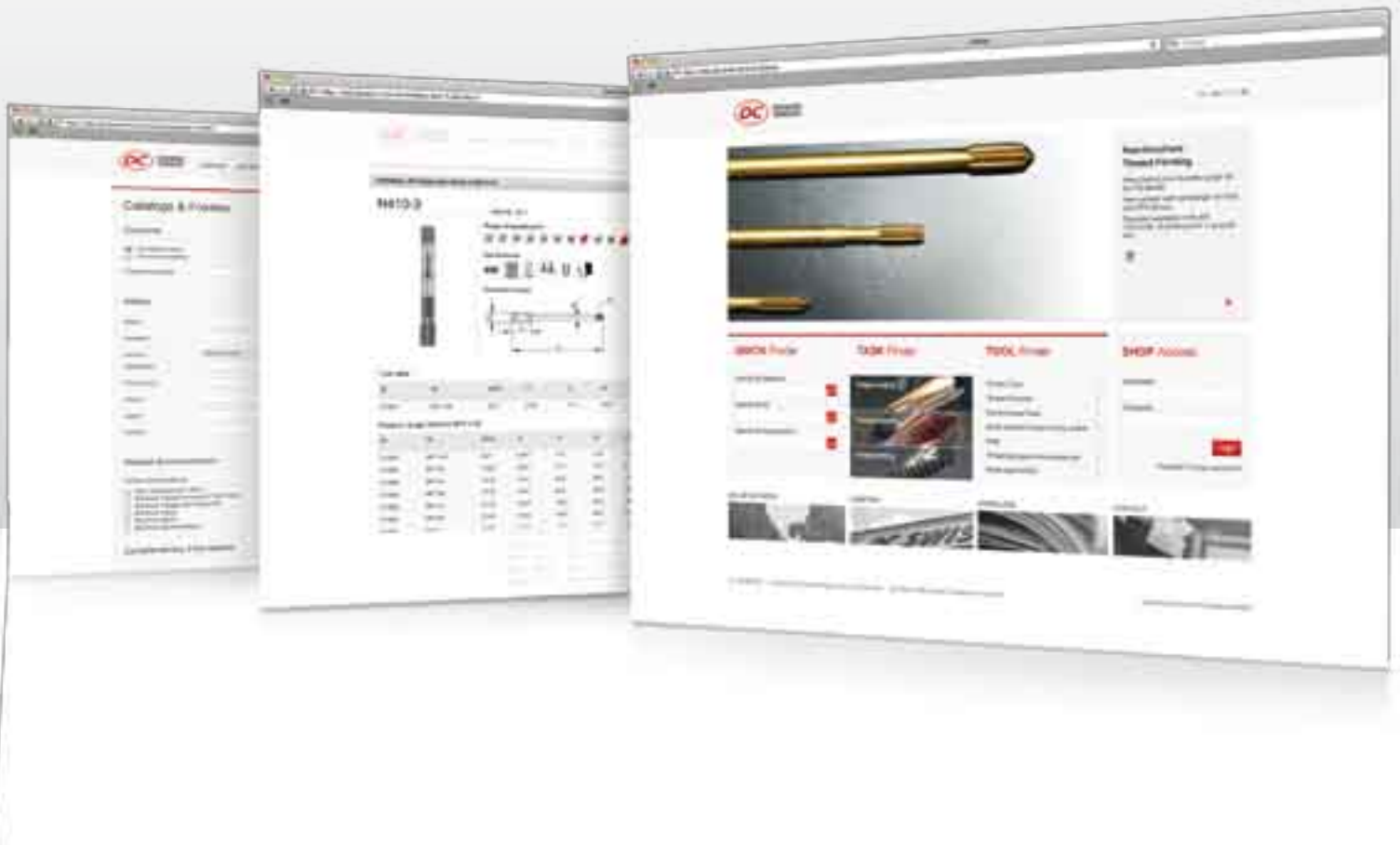















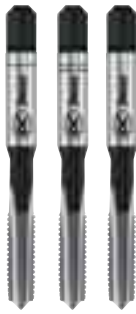





















$\varnothing d_1$ MF	P mm	l_1 mm	l_2 mm	d_2 mm	a mm			ID	ID	ID
20	1.00	112	37.0	14.0	11.2	4	19.00	103332	103537	111198
20	1.25	112	37.0	14.0	11.2	4	18.80		103539	
20	1.50	112	37.0	14.0	11.2	4	18.50	103334	103540	111195
22	1.00	115	32.0	16.0	12.5	4	21.00		103545	
22	1.50	115	32.0	16.0	12.5	4	20.50	103340	103546	121669
22	2.00	115	32.0	16.0	12.5	3	20.00		103548	
24	1.00	120	30.0	18.0	14.0	4	23.00		103552	
24	1.50	120	30.0	18.0	14.0	4	22.50	103343	103553	111202
24	2.00	130	45.0	18.0	14.0	4	22.00	103344	103555	111203
25	1.00	120	30.0	18.0	14.0	4	24.00		103559	
25	1.50	120	30.0	18.0	14.0	4	23.50		103560	
25	2.00	120	30.0	18.0	14.0	4	23.00		103561	
26	1.00	120	30.0	18.0	14.0	4	25.00		103562	
26	1.50	120	30.0	18.0	14.0	4	24.50	103346	103563	111207
26	2.00	120	30.0	18.0	14.0	4	24.00		103564	
27	1.00	127	30.0	20.0	16.0	4	26.00		103565	
27	1.50	127	30.0	20.0	16.0	4	25.50		103566	
27	2.00	135	45.0	20.0	16.0	4	25.00	* 103351	* 103567	* 111210
28	1.00	127	30.0	20.0	16.0	4	27.00		103570	
28	1.50	127	30.0	20.0	16.0	4	26.50		103571	
30	1.50	127	32.0	20.0	16.0	4	28.50	103355	103575	111214
30	2.00	127	32.0	20.0	16.0	4	28.00	103356	103577	111215

MORE PERSONAL.
MORE ACCURATE.
MORE COMPLETE.
MORE **YOU.**



























DCSWISS.COM

		N					Z	
Merkmale Characteristics				 V	 R40 V	 	 V	 VS
								
Lochart Hole type								
		N310-3	N320-3 N320-4	N320V-4	N360-3 N360V-3	N1110 -1-2-3-S	Z320V-3 Z320V-4	Z320VS-4
DIN lang DIN long	DIN 371	114	114	114	116		118	118
ISO kurz ISO short	ISO 529					128		
Toleranz Tolerance	UNC 2B	114	114	114	116	128	118	118
Toleranz Tolerance	UNC 3B							
Toleranz Tolerance	UNC(J) 3B		114		116			
		N410-3	N420-4	N420V-4	N460-3 N460V-3	N1210 -1-2-3-S	Z420V-4	Z420VS-4
DIN lang DIN long	DIN 376	115	115	115	117		118	118
ISO kurz ISO short	ISO 529					129		
Toleranz Tolerance	UNC 2B	115	115	115	117	129	118	118
Toleranz Tolerance	UNC 3B							
Toleranz Tolerance	UNC(J) 3B							

Z		H		S		SA		
								
								
								
								
Z360V-3 Z362V-3	Z370VS-3	H320-4	H350-3	S320VS-4	S360VS-3	SA320-4	SA350-3	SA390-3
119	120	121	121	122	123	124	124	125
119	120	121	121	122	123	124	124	
	120			122		124	124	125
Z462V-3	Z470VS-3	H420-4	H450-3	S420VS-4	S460VS-3	SA420-4	SA450-3	
119	120	121	121	122	123	125	125	
119	120	121	121	122	123	125	125	











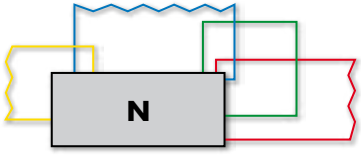







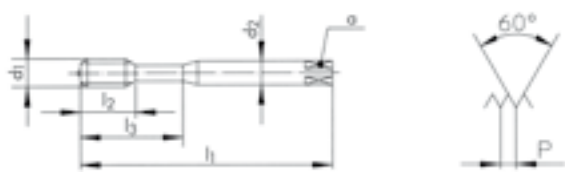









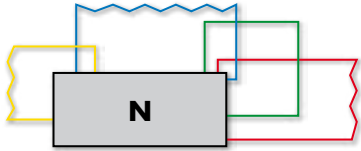





		TL		RTS		FS	FPS	FAS
Merkmale Characteristics								
		VS	 VS	VS	VS	VS	VS	VS
								
Lochart Hole type								
		TL320VS-4	TL351VS-3	RTS320VS-4	RTS362VS-3	FS380VS-3	FPS381VS-3	FAS381VS-3
<i>DIN lang</i> DIN long	DIN 371	124	124	126	126			
<i>DIN lang</i> DIN long	~ DIN 2184-1					127	127	127
<i>Toleranz</i> Tolerance	UNC 2B	124	124	126	126	127	127	127
<i>Toleranz</i> Tolerance	UNC 3B							
<i>Toleranz</i> Tolerance	UNC(J) 3B	124	124					
				RTS420VS-4	RTS462VS-3			
<i>DIN lang</i> DIN long	DIN 376			126	126			
<i>DIN lang</i> DIN long	~ DIN 2184-1							
<i>Toleranz</i> Tolerance	UNC 2B			126	126			
<i>Toleranz</i> Tolerance	UNC 3B							
<i>Toleranz</i> Tolerance	UNC(J) 3B							



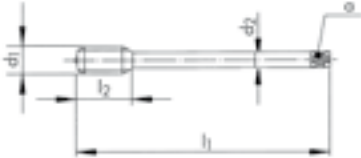



aero

THREADING TOOLS FOR AEROSPACE MATERIALS

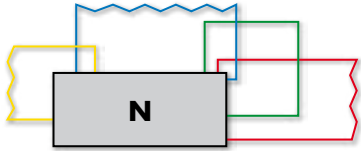
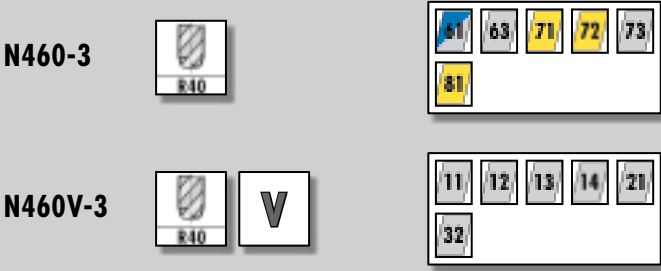

										N310-3	N320-4	N320V-4	
													
N310-3													
N320-4													
N320V-4	 												
													
													
Ø" d ₁ UNC	P TPI	d ₁ mm	l ₁ mm	l ₂ mm	l ₃ mm	d ₂ mm	α mm			ID	ID	ID	
*2	56	2.18	45	9.0		2.8	2.1	2	1.75		101469	143690	
*3	48	2.51	50	10.0		2.8	2.1	2	2.00		101470		
4	40	2.84	56	12.0	18	3.5	2.7	3	2.25	101450	101511	142738	
5	40	3.17	56	12.0	18	3.5	2.7	3	2.55		101512		
6	32	3.50	56	13.0	20	4.0	3.0	3	2.75	101451	101514	144402	
8	32	4.16	63	14.0	21	4.5	3.4	3	3.40	101452	101515	142739	
10	24	4.82	70	15.0	25	6.0	4.9	3	3.80	101449	101508	142740	
12	24	5.48	80	17.0	30	6.0	4.9	3	4.40		101509		
1/4	20	6.35	80	17.0	30	7.0	5.5	3	5.10	101448	101507	142741	
													
Ø" d ₁ UNC	P TPI	d ₁ mm	l ₁ mm	l ₂ mm	l ₃ mm	d ₂ mm	α mm			ID			
4	40	2.84	56	12.0	18	3.5	2.7	3	2.30		145656		
6	32	3.50	56	13.0	20	4.0	3.0	3	2.80		155317		
8	32	4.16	63	14.0	21	4.5	3.4	3	3.45		155319		
* N320-3													

									N410-3	N420-4	N420V-4
									N410-3		
N420-4											
N420V-4	 V										
 											
									2B	2B	2B
\varnothing " d ₁ UNC	P TPI	d ₁ mm	l ₁ mm	l ₂ mm	d ₂ mm	a mm			ID	ID	ID
5/16	18	7.93	90	20.0	6.0	4.9	3	6.50	101997	102213	142742
3/8	16	9.52	100	22.0	7.0	5.5	3	8.00	101996	102212	142743
7/16	14	11.11	100	19.0	8.0	6.2	3	9.30		102215	142744
1/2	13	12.70	110	24.0	9.0	7.0	3	10.80	101993	102208	142745
9/16	12	14.28	110	28.0	11.0	9.0	3	12.20		102217	
5/8	11	15.87	110	30.0	12.0	9.0	3	13.60	101998	102214	142746
3/4	10	19.05	125	33.0	14.0	11.0	3	16.60	101995	102211	142747
7/8	9	22.22	140	36.0	18.0	14.5	3	19.50		102216	142748
1	8	25.40	160	39.0	18.0	14.5	4	22.30	101994	102209	142749
1 1/8	7	28.57	180	45.0	22.0	18.0	4	25.00		102205	
1 1/4	7	31.75	180	45.0	22.0	18.0	4	28.20	* 101991	102204	
1 1/2	6	38.10	200	55.0	32.0	24.0	4	34.00	* 101990	102203	
1 3/4	5	44.45	220	59.0	36.0	29.0	4	39.50	* 101992	102206	
2	4.5	50.80	250	67.0	40.0	32.0	4	45.30		102210	

										N460-3	N460V-3		
													
													
													
													
$\varnothing'' d_1$ UNC	P TPI	d_1 mm	l_1 mm	l_2 mm	d_2 mm	a mm			$\rightarrow \leftarrow$	ID	ID		
7/16	14	11.11	100	14.0	8.0	6.2	3	9.30		102424	105135		
1/2	13	12.70	110	14.0	9.0	7.0	3	10.80		102420	102497		
9/16	12	14.28	110	14.0	11.0	9.0	3	12.20		102426	102502		
5/8	11	15.87	110	18.0	12.0	9.0	3	13.60		102423	102500		
3/4	10	19.05	125	21.0	14.0	11.0	3	16.60		102422	102499		
7/8	9	22.22	140	24.0	18.0	14.5	4	19.50		102425	102501		
1	8	25.40	160	27.0	18.0	14.5	4	22.30		102421	102498		
1 1/8	7	28.57	180	30.0	22.0	18.0	4	25.00		102418	102495		
1 1/4	7	31.75	180	30.0	22.0	18.0	4	28.20		102417	102494		
1 1/2	6	38.10	200	40.0	32.0	24.0	5	34.00		102416	102493		
1 3/4	5	44.45	220	44.0	36.0	29.0	5	39.50			128062		
2	4.5	50.80	250	52.0	40.0	32.0	5	45.30			128084		

										Z320V-4	Z320VS-4	Z420V-4	Z420VS-4
Z320V-4													
Z320VS-4													
Z420V-4													
Z420VS-4													
\varnothing d ₁ UNC	P TPI	d ₁ mm	l ₁ mm	l ₂ mm	l ₃ mm	d ₂ mm	a mm			ID	ID	ID	ID
*2	56	2.18	45	9.0		2.8	2.1	2	1.75	142750			
4	40	2.84	56	12.0	18	3.5	2.7	3	2.25	142751			
6	32	3.50	56	13.0	20	4.0	3.0	3	2.75	142752	111560		
8	32	4.16	63	14.0	21	4.5	3.4	3	3.40	142753	111561		
10	24	4.82	70	15.0	25	6.0	4.9	3	3.80	142754	111562		
1/4	20	6.35	80	17.0	30	7.0	5.5	3	5.10	142755	111563		
5/16	18	7.93	90	20.0	35	8.0	6.2	3	6.50	142756	111564		
3/8	16	9.52	100	22.0	39	10.0	8.0	3	8.00	142757	111565		
1/2	13	12.70	110	24.0		9.0	7.0	3	10.80			142758	111566
5/8	11	15.87	110	30.0		12.0	9.0	3	13.60			142759	111567
3/4	10	19.05	125	33.0		14.0	11.0	4	16.60			142760	111568
7/8	9	22.22	140	36.0		18.0	14.5	4	19.50			142761	
1	8	25.40	160	39.0		18.0	14.5	4	22.30			142762	

* Z320V-3



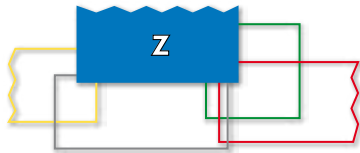

Z362V-3

Z362VS-3

Z462V-3



Z362V-3



Z362VS-3



Z462V-3

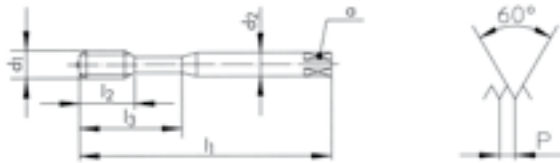

Ø" d ₁ UNC	P TPI	d ₁ mm	l ₁ mm	l ₂ mm	l ₃ mm	d ₂ mm	a mm		
*2	56	2.18	45	8.0		2.8	2.1	2	1.75
*4	40	2.84	56	5.5	18	3.5	2.7	3	2.25
6	32	3.50	56	6.5	20	4.0	3.0	3	2.75
8	32	4.16	63	7.5	21	4.5	3.4	3	3.40
10	24	4.82	70	9.0	25	6.0	4.9	3	3.80
1/4	20	6.35	80	11.0	30	7.0	5.5	3	5.10
5/16	18	7.93	90	12.5	35	8.0	6.2	3	6.50
3/8	16	9.52	100	14.0	39	10.0	8.0	3	8.00
7/16	14	11.11	100	14.0		8.0	6.2	3	9.30
1/2	13	12.70	110	14.0		9.0	7.0	3	10.80
5/8	11	15.87	110	18.0		12.0	9.0	3	13.60
3/4	10	19.05	125	21.0		14.0	11.0	3	16.60
7/8	9	22.22	140	24.0		18.0	14.5	3	19.50
1	8	25.40	160	27.0		18.0	14.5	4	22.30

ID **ID** **ID**

* Z360V-3

										Z370VS-3	Z470VS-3		
<p>Z370VS-3</p>													
<p>Z470VS-3</p>													
Ø" d ₁ UNC	P TPI	d ₁ mm	l ₁ mm	l ₂ mm	l ₃ mm	d ₂ h ₆ mm	a mm			ID	ID		
6	32	3.50	56	6.5	20	4.0(h9)	3.0	3	2.75	166123			
8	32	4.16	63	7.5	21	4.5(h9)	3.4	3	3.40	166124			
10	24	4.82	70	9.0	25	6.0	4.9	3	3.80	166125			
1/4	20	6.35	80	11.0	30	*6.0	*4.9	3	5.10	166126			
5/16	18	7.93	90	12.5	35	8.0	6.2	3	6.50	166127			
3/8	16	9.52	100	14.0	39	10.0	8.0	3	8.00	166128			
7/16	14	11.11	100	14.0		8.0	6.2	3	9.30		166129		
1/2	13	12.70	110	14.0		*10.0	*8.0	4	10.80		166130		
5/8	11	15.87	110	18.0		12.0	9.0	4	13.60		166131		
3/4	10	19.05	125	21.0		14.0	11.0	4	16.60		166132		
1	8	25.40	160	27.0		16.0	12.0	4	22.30		175703		
* Norme DC / * DC Norm / * Norma DC													
Ø" d ₁ UNC	P TPI	d ₁ mm	l ₁ mm	l ₂ mm	l ₃ mm	d ₂ h ₆ mm	a mm			ID			
4	40	2.84	56	5.5	18	3.5(h9)	2.7	3	2.30	165114			
6	32	3.50	56	6.5	20	4.0(h9)	3.0	3	2.80	165115			
8	32	4.16	63	7.5	21	4.5(h9)	3.4	3	3.45	165116			
1/4	20	6.35	80	11.0	30	*6.0	*4.9	3	5.20	165117			
5/16	18	7.93	90	12.5	35	8.0	6.2	3	6.70	165118			
* Norme DC / * DC Norm / * Norma DC													

UNC ANSI B1.1

PM

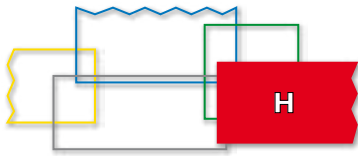
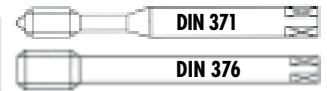

H320-4 H420-4 H350-3 H450-3



H320-4



H420-4



H350-3



H450-3

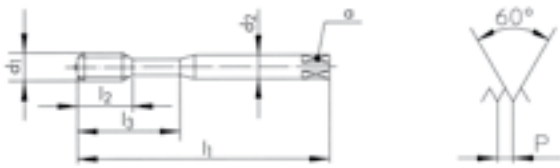

Ø" d ₁ UNC	P TPI	d ₁ mm	l ₁ mm	l ₂ mm	l ₃ mm	d ₂ mm	a mm		
2	56	2.18	45	8.0		2.8	2.1	2	1.75
4	40	2.84	56	10.0	18	3.5	2.7	3	2.25
6	32	3.50	56	13.0	20	4.0	3.0	3	2.75
8	32	4.16	63	14.0	21	4.5	3.4	3	3.40
10	24	4.82	70	15.0	25	6.0	4.9	3	3.80
1/4	20	6.35	80	17.0	30	7.0	5.5	3	5.10
5/16	18	7.93	90	20.0	35	8.0	6.2	3	6.50
3/8	16	9.52	100	22.0	39	10.0	8.0	3	8.00
1/2	13	12.70	110	24.0		9.0	7.0	4	10.80

ID	ID
101221	
101223	
101225	
101226	
101220	
101219	
101224	
101222	
	101290

Ø" d ₁ UNC	P TPI	d ₁ mm	l ₁ mm	l ₂ mm	l ₃ mm	d ₂ mm	a mm		
2	56	2.18	45	8.0		2.8	2.1	2	1.75
4	40	2.84	56	5.5	18	3.5	2.7	3	2.25
6	32	3.50	56	6.5	20	4.0	3.0	3	2.75
8	32	4.16	63	7.5	21	4.5	3.4	3	3.40
10	24	4.82	70	9.0	25	6.0	4.9	3	3.80
1/4	20	6.35	80	11.0	30	7.0	5.5	3	5.10
5/16	18	7.93	90	12.5	35	8.0	6.2	3	6.50
3/8	16	9.52	100	14.0	39	10.0	8.0	3	8.00
7/16	14	11.11	100	14.0		8.0	6.2	3	9.30
1/2	13	12.70	110	14.0		9.0	7.0	4	10.80
5/8	11	15.87	110	18.0		12.0	9.0	4	13.60
3/4	10	19.05	125	21.0		14.0	11.0	4	16.60
1	8	25.40	160	27.0		18.0	14.5	4	22.30

ID	ID
	101258
	101260
	101262
	101263
	101257
	101256
	101261
	101259
	101330
	101326
	101329
	101328
	101327

										S320VS-4	S420VS-4		
S320VS-4		VS											
S420VS-4		VS											
										B 4xP	B 4xP		
										2B	2B		
\varnothing d ₁ UNC	P TPI	d ₁ mm	l ₁ mm	l ₂ mm	l ₃ mm	d ₂ mm	a mm			ID	ID		
6	32	3.50	56	13.0	20	4.0	3.0	3	2.75	111587			
8	32	4.16	63	14.0	21	4.5	3.4	3	3.40	111588			
10	24	4.82	70	15.0	25	6.0	4.9	3	3.80	* 111589			
1/4	20	6.35	80	17.0	30	7.0	5.5	3	5.10	111590			
5/16	18	7.93	90	20.0	35	8.0	6.2	3	6.50	111591			
3/8	16	9.52	100	22.0	39	10.0	8.0	3	8.00	111592			
1/2	13	12.70	110	24.0		9.0	7.0	4	10.80		111593		
5/8	11	15.87	110	30.0		12.0	9.0	4	13.60		111594		
3/4	10	19.05	125	33.0		14.0	11.0	4	16.60		111595		
										3B UNC(J)			
\varnothing d ₁ UNC	P TPI	d ₁ mm	l ₁ mm	l ₂ mm	l ₃ mm	d ₂ mm	a mm			ID			
4	40	2.84	56	12.0	18	3.5	2.7	3	2.30	165314			
6	32	3.50	56	13.0	20	4.0	3.0	3	2.80	165315			
8	32	4.16	63	14.0	21	4.5	3.4	3	3.45	165316			
1/4	20	6.35	80	17.0	30	7.0	5.5	3	5.20	165317			
5/16	18	7.93	90	20.0	35	8.0	6.2	3	6.70	* 143761			

											S360VS-3	S460VS-3		
											<p>S360VS-3 </p> <p>S460VS-3 </p>			
Ø" d ₁ UNC	P TPI	d ₁ mm	l ₁ mm	l ₂ mm	l ₃ mm	d ₂ mm	a mm				ID	ID		
6	32	3.50	56	6.5	20	4.0	3.0	3	3	2.75	111530			
8	32	4.16	63	7.5	21	4.5	3.4	3	3	3.40	111531			
10	24	4.82	70	9.0	25	6.0	4.9	3	3	3.80	* 111532			
1/4	20	6.35	80	11.0	30	7.0	5.5	3	3	5.10	111533			
5/16	18	7.93	90	12.5	35	8.0	6.2	3	3	6.50	111534			
3/8	16	9.52	100	14.0	39	10.0	8.0	3	3	8.00	111535			
1/2	13	12.70	110	14.0		9.0	7.0	4	4	10.80		111537		
3/4	10	19.05	125	21.0		14.0	11.0	4	4	16.60		* 111539		

aero

										SA320-4	SA350-3	TL320VS-4	TL351VS-3
\varnothing " d ₁ UNC	P TPI	d ₁ mm	l ₁ mm	l ₂ mm	l ₃ mm	d ₂ mm	a mm			ID	ID	ID	ID
4	40	2.84	56	12.0		3.5	2.7	3	2.25	147271	149003		152018
5	40	3.17	56	12.0		3.5	2.7	3	2.55	* 149031	* 149033	* 152023	* 152024
6	32	3.50	56	13.0		4.0	3.0	3	2.75	149055	149057	* 152027	152028
8	32	4.16	63	14.0		4.5	3.4	3	3.40	149093	149095	* 152036	152037
10	24	4.82	70	15.0		6.0	4.9	3	3.80	149125	* 149127	* 152042	* 152043
1/4	20	6.35	80	15.0	23	7.0	5.5	3	5.10	149222	149224	* 152062	127972
5/16	18	7.93	90	18.0	29	8.0	6.2	3	6.50	149269	149271		152068
3/8	16	9.52	100	20.0	33	10.0	8.0	3	8.00	149346	149348	* 152084	152085
\varnothing " d ₁ UNC	P TPI	d ₁ mm	l ₁ mm	l ₂ mm	l ₃ mm	d ₂ mm	a mm			ID	ID	ID	ID
4	40	2.84	56	12.0		3.5	2.7	3	2.30	149005	149007	* 148804	150194
6	32	3.50	56	13.0		4.0	3.0	3	2.80	149059	149061	* 152029	150210
8	32	4.16	63	14.0		4.5	3.4	3	3.45	149097	149099	* 152038	152039
10	24	4.82	70	15.0		6.0	4.9	3	3.90	* 149129	* 149131		* 152045
1/4	20	6.35	80	15.0	23	7.0	5.5	3	5.20	149226	149228	* 152063	152064
5/16	18	7.93	90	18.0	29	8.0	6.2	3	6.70	149273	149275	* 152069	152070
3/8	16	9.52	100	20.0	33	10.0	8.0	3	8.10	149350	149352	* 152086	152087

aero

SA420-4

SA450-3

SA390-3

SA420-4



SA450-3



SA390-3

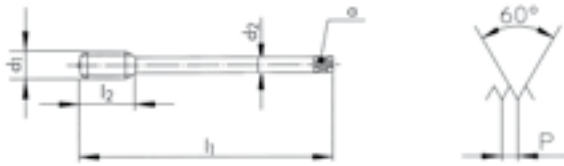

\varnothing " d ₁ UNC	P TPI	d ₁ mm	l ₁ mm	l ₂ mm	d ₂ mm	a mm		
7/16	14	11.11	100	22.0	8.0	6.2	3	9.30
1/2	13	12.70	110	24.0	9.0	7.0	4	10.80
5/8	11	15.87	110	30.0	12.0	9.0	4	13.60
3/4	10	19.05	125	33.0	14.0	11.0	4	16.60

ID

ID

* 152246

152247

152252

152249

152254

* 152250

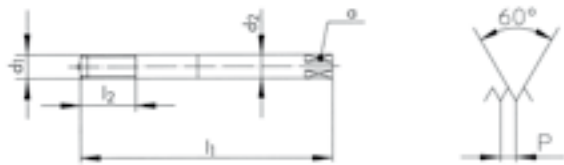

\varnothing " d ₁ UNC	P TPI	d ₁ mm	l ₁ mm	l ₂ mm	d ₂ mm	a mm		
4	40	2.84	56	12.0	3.5	2.7	3	2.30
6	32	3.50	56	13.0	4.0	3.0	3	2.80
8	32	4.16	63	14.0	4.5	3.4	3	3.45
10	24	4.82	70	15.0	6.0	4.9	3	3.90
1/4	20	6.35	80	20.0	7.0	5.5	3	5.20
5/16	18	7.93	90	25.0	8.0	6.2	3	6.70
3/8	16	9.52	100	30.0	10.0	8.0	3	8.10

3B
UNC(J)

ID

149652

149666

149677

149685

149713

149726

149747



Uniquement pour taraudage synchrone
Nur für Synchrobearbeitung
Only for rigid tapping
Solo per maschiatura sincrona
Solo para roscado sincronizado

PM

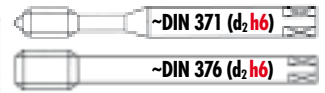

RTS Rigid Tapping Synchro

RTS320VS-4

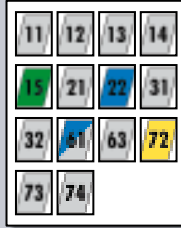

RTS420VS-4



RTS362VS-3

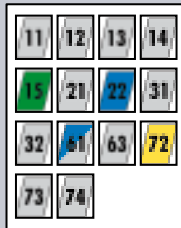

RTS462VS-3



RTS320VS-4

RTS420VS-4

RTS362VS-3

RTS462VS-3

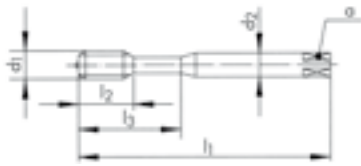

Ø" d ₁ UNC	P TPI	d ₁ mm	l ₁ mm	l ₂ mm	l ₃ mm	d ₂ h6 mm	α mm		
6	32	3.50	56	6.5	20	4.0(h9)	3.0	3	2.75
8	32	4.16	63	7.5	21	4.5(h9)	3.4	3	3.40
10	24	4.82	70	9.0	25	6.0	4.9	3	3.80
1/4	20	6.35	80	11.0	30	*6.0	*4.9	3	5.10
5/16	18	7.93	90	12.5	35	8.0	6.2	3	6.50
3/8	16	9.52	100	14.0	39	10.0	8.0	3	8.00
1/2	13	12.70	110	14.0		*10.0	*8.0	3	10.80

ID

ID

ID

ID

157395

157402

157396

157403

157397

157404

157398

157405

157399

157406

157400

157407

157401

157408

* Norme DC / * DC Norm / * Norma DC



sur demande
auf Anfrage
on request
su richiesta
sobre pedido

FS FPS FAS FORMING

FS380VS-3

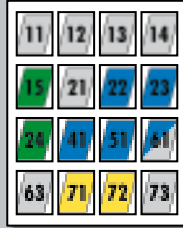

FPS381VS-3



FAS381VS-3

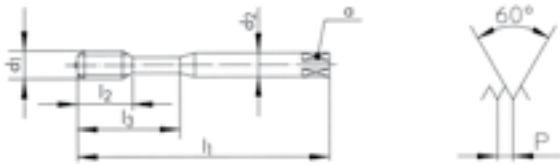

$\varnothing'' d_1$ UNC	P TPI	d_1 mm	l_1 mm	l_2 mm	l_3 mm	d_2 mm	α mm	2BX Tol. → ←
2	56	2.18	45	9.0		2.8	2.1	1.95 + 0.02
4	40	2.84	56	12.0	18	3.5	2.7	2.55 + 0.03
6	32	3.50	56	13.0	20	4.0	3.0	3.15 + 0.03
8	32	4.16	63	14.0	21	4.5	3.4	3.80 + 0.03
10	24	4.82	70	15.0	25	6.0	4.9	4.35 + 0.05
1/4	20	6.35	80	17.0	30	7.0	5.5	5.75 + 0.05
5/16	18	7.93	90	20.0	35	8.0	6.2	7.30 + 0.05

FS380VS-3



FPS381VS-3



FAS381VS-3



2BX

2BX

2BX

ID

ID

ID

157285

170063
166713
166714
166715
166716
* 166717

170065
166725
166726
166727
166728
* 166729

UNC ANSI B1.1

≤ Ø 2.8 > Ø 2.8

PM

HSS

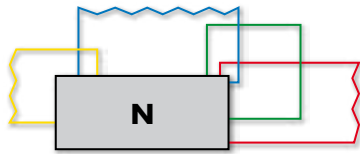
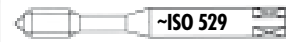

N1110-1

N1110-2

N1110-3

N1110-S



N1110-1

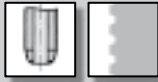

N1110-2

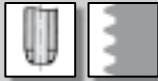

N1110-3

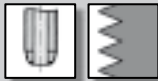

N1110-S



2B

2B

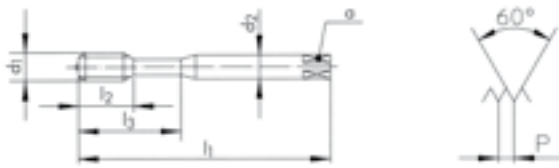

Ø" d ₁ UNC	P TPI	d ₁ mm	l ₁ mm	l ₂ mm	l ₃ mm	d ₂ mm	a mm		
2	56	2.18	45	9.5		2.80	2.10	3	1.75
3	48	2.51	45	9.5		2.80	2.10	3	2.00
4	40	2.84	48	11.0	18	3.15	2.50	3	2.25
5	40	3.17	48	11.0	18	3.15	2.50	3	2.55
6	32	3.50	50	13.0	20	3.55	2.80	3	2.75
8	32	4.16	53	13.0	21	4.50	3.55	3	3.40
10	24	4.82	58	16.0	25	5.00	4.00	3	3.80
1/4	20	6.35	66	19.0	30	6.30	5.00	3	5.10
5/16	18	7.93	72	22.0	35	8.00	6.30	3	6.50
3/8	16	9.52	80	24.0	39	10.00	8.00	3	8.00

ID

ID

ID

ID

102799

102885

102998

111067

* 102800

* 102886

* 102999

* 111068

102802

102888

103001

111070

103002

102805

102891

103004

111073

102806

102892

103005

111074

102797

102883

102996

111065

102796

102882

102995

111064

102804

102890

103003











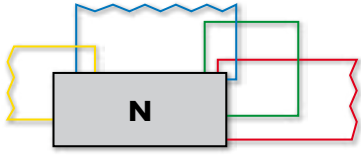
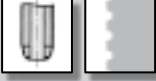













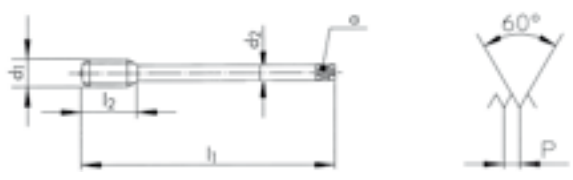



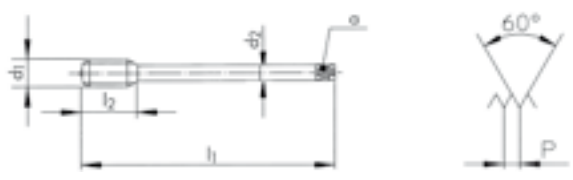

111072

102801





















102887

103000

111069

										N1210-1	N1210-2	N1210-3	N1210-S
										N1210-1			
N1210-2													
N1210-3													
N1210-S													
													
													
\varnothing d ₁ UNC	P TPI	d ₁ mm	l ₁ mm	l ₂ mm	d ₂ mm	a mm				ID	ID	ID	ID
7/16	14	11.11	85	22.0	8.0	6.3	3	9.30		103392	103466	103606	111236
1/2	13	12.70	89	24.0	9.0	7.1	3	10.80		103387	103461	103601	111229
5/8	11	15.87	102	32.0	12.5	10.0	3	13.60		103391	103465	103605	111235
3/4	10	19.05	112	33.0	14.0	11.2	3	16.60		103390	103464	103604	111234
1	8	25.40	130	45.0	18.0	14.0	4	22.30		103388	103462	103602	111230

UNF, UNEF, UNS, UN *Inhaltsverzeichnis - Maschinen- und Handgewindebohrer ANSI B1.1* Directory - Machine and hand taps ANSI B1.1

























		N						
Merkmale Characteristics				 V	 R40	 R40 V	 	
							 	
Lochart Hole type								
		N310-3	N320-3 N320-4	N320V-4	N360-3	N360V-3	N1110 -1-3-S	N1120-4
DIN lang DIN long	DIN 371	134	134	134	136	136		
ISO kurz ISO short	ISO 529						148	150
Toleranz Tolerance	UNF 2B	134	134	134	136	136	148	
Toleranz Tolerance	UNJF 3B							
Toleranz Tolerance	UNF(J) 3B		134		136			
Toleranz Tolerance	UNEF 2B						150	150
Toleranz Tolerance	UNS 2B							
Toleranz Tolerance	UN 2B							
		N410-3	N420-4	N420V-4	N460-3	N460V-3	N1210 -1-3-S	N1220-4
DIN lang DIN long	DIN 374	135/151	135	135	137	137		
ISO kurz ISO short	ISO 529						149	150
Toleranz Tolerance	UNF 2B	135	135	135	137	137	149	
Toleranz Tolerance	UNJF 3B							
Toleranz Tolerance	UNF(J) 3B		135		137			
Toleranz Tolerance	UNEF 2B						150	150
Toleranz Tolerance	UNS 2B	151			151	151		
Toleranz Tolerance	UN 2B				151	151		

UNF, UNJF

Inhaltsverzeichnis - Maschinengewindebohrer ANSI B1.1 / ASME B1.15 Directory - Machine taps ANSI B1.1 / ASME B1.15

Z			H		S		SA	
								
V	V	VS			VS	VS		
								
								
Z320V-4	Z360V-3	Z370VS-3	H320-4	H350-3	S320VS-4	S360VS-3	SA320-4	SA320-4
138	138	139	140	141	142	142	143	145
138	138	139	140	141		142	143	145
		139			142	142	143	
Z420V-4	Z460V-3	Z470VS-3	H420-4	H450-3	S420VS-4	S460VS-3	SA420-4	
138	138	139	140	141	142	142	144	
138	138	139	140	141		142	144	
					142	142	144	

UNF, UNJF, UNS, UN

		SA		TL		RTS		
Merkmale Characteristics								
								
								
Lochart Hole type								
		SA350-3	SA390-3	TL320VS-4	TL351VS-3	RTS320VS-4	RTS362VS-3	
DIN lang DIN long	DIN 371	143	145	143	143	146	146	
DIN lang DIN long	~ DIN 2184-1							
Toleranz Tolerance	UNF 2B	143		143	143	146	146	
Toleranz Tolerance	UNF(J) 3B	143	145	143	143			
Toleranz Tolerance	UNEF 2B							
Toleranz Tolerance	UNS 2B							
Toleranz Tolerance	UN 2B							
		SA450-3		TL420VS-4	TL451VS-3	RTS420VS-4	RTS462VS-3	
DIN lang DIN long	DIN 374	144		144	144	146	146	
DIN lang DIN long	~ DIN 2184-1							
Toleranz Tolerance	UNF 2B	144			144	146	146	
Toleranz Tolerance	UNF(J) 3B	144		144	144			
Toleranz Tolerance	UNEF 2B							
Toleranz Tolerance	UNS 2B							
Toleranz Tolerance	UN 2B							

UNF ANSI B1.1

≤ Ø 2.8 > Ø 2.8

PM **HSSE**













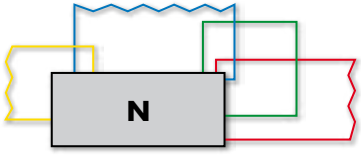





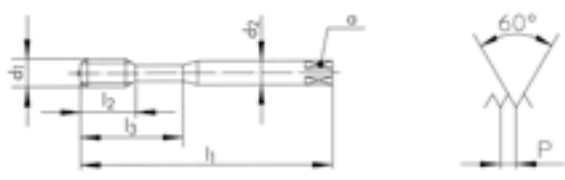

										N310-3	N320-3	N320-4	N320V-4
N310-3													
N320-3													
N320-4													
N320V-4	V												
Ø" d ₁	P	d ₁	l ₁	l ₂	l ₃	d ₂	a			ID	ID	ID	ID
UNF	TPI	mm	mm	mm	mm	mm	mm						
0	80	1.52	40	7.0		2.5	2.1	2	1.20		101475		
1	72	1.85	40	8.0		2.5	2.1	2	1.50		* 101476		
2	64	2.18	45	9.0		2.8	2.1	2	1.80		101477		
4	48	2.84	56	12.0	18	3.5	2.7	3	2.35			128847	
5	44	3.17	56	12.0	18	3.5	2.7	3	2.60			142764	
6	40	3.50	56	13.0	20	4.0	3.0	3	2.90			101519	142765
8	36	4.16	63	14.0	21	4.5	3.4	3	3.50			101520	
10	32	4.82	70	15.0	25	6.0	4.9	3	4.05			101517	142766
12	28	5.48	80	17.0	30	6.0	4.9	3	4.60			101518	
1/4	28	6.35	80	17.0	30	7.0	5.5	3	5.50	101453		101516	142767
Ø" d ₁	P	d ₁	l ₁	l ₂	l ₃	d ₂	a			ID			
UNF	TPI	mm	mm	mm	mm	mm	mm						
10	32	4.82	70	15.0	25	6.0	4.9	3	4.15	135506			
1/4	28	6.35	80	17.0	30	7.0	5.5	3	5.55	155323			

UNF ANSI B1.1



										N410-3	N420-4	N420V-4	
N410-3													
N420-4													
N420V-4													
$\varnothing'' d_1$ UNF	P TPI	d_1 mm	l_1 mm	l_2 mm	d_2 mm	α mm				ID	ID	ID	
5/16	24	7.93	90	20.0	6.0	4.9	3	6.90	102004	102223	142774		
3/8	24	9.52	100	22.0	7.0	5.5	3	8.50	102003	102222	142775		
7/16	20	11.11	100	19.0	8.0	6.2	3	9.80	102006	102225	142776		
1/2	20	12.70	100	24.0	9.0	7.0	3	11.40	102000	102219	142777		
9/16	18	14.28	100	24.0	11.0	9.0	3	12.90		102227			
5/8	18	15.87	100	26.0	12.0	9.0	3	14.50	102005	102224	142778		
3/4	16	19.05	125	33.0	14.0	11.0	4	17.50	102002	102221	142779		
7/8	14	22.22	140	36.0	18.0	14.5	4	20.40	* 102007	102226			
1	12	25.40	160	39.0	18.0	14.5	4	23.30		102220	142780		
1 1/8	12	28.57	180	39.0	22.0	18.0	4	26.50		142773			
1 1/4	12	31.75	180	39.0	22.0	18.0	4	29.70		102218			
1 3/8	12	34.92	200	36.0	28.0	22.0	4	32.80		105137			
1 1/2	12	38.10	200	41.0	32.0	24.0	4	36.00	* 110986	105138			
$\varnothing'' d_1$ UNF	P TPI	d_1 mm	l_1 mm	l_2 mm	d_2 mm	α mm				ID			
5/16	24	7.93	90	20.0	6.0	4.9	3	7.00		155328			
3/8	24	9.52	100	22.0	7.0	5.5	3	8.60		155326			
7/16	20	11.11	100	19.0	8.0	6.2	3	10.00		155330			
1/2	20	12.70	100	24.0	9.0	7.0	3	11.55		155321			

UNF

										N360-3	N360V-3		
										 			
<p>N360-3</p>  													
<p>N360V-3</p>   													
										 			
										 			
$\varnothing'' d_1$ UNF	P TPI	d_1 mm	l_1 mm	l_2 mm	l_3 mm	d_2 mm	a mm			ID	ID		
6	40	3.50	56	6.5	20	4.0	3.0	3	2.90	101686			
8	36	4.16	63	7.5	21	4.5	3.4	3	3.50	* 101687	* 101733		
10	32	4.82	70	9.0	25	6.0	4.9	3	4.05	101682	101730		
12	28	5.48	80	11.0	30	6.0	4.9	3	4.60	101683			
1/4	28	6.35	80	11.0	30	7.0	5.5	3	5.50	101681	101729		
5/16	24	7.93	90	12.5	35	8.0	6.2	3	6.90	101685	101732		
3/8	24	9.52	100	14.0	39	10.0	8.0	3	8.50	101684	101731		
													
$\varnothing'' d_1$ UNF	P TPI	d_1 mm	l_1 mm	l_2 mm	l_3 mm	d_2 mm	a mm			ID			
10	32	4.82	70	9.0	25	6.0	4.9	3	4.15	155325			
1/4	28	6.35	80	11.0	30	7.0	5.5	3	5.55	155324			
5/16	24	7.93	90	12.5	35	8.0	6.2	3	7.00	155329			
3/8	24	9.52	100	14.0	39	10.0	8.0	3	8.60	155327			

UNF ANSI B1.1

HSSE



										N460-3	N460V-3						
N460-3 																	
N460V-3 																	
$\varnothing'' d_1$ UNF	P TPI	d_1 mm	l_1 mm	l_2 mm	d_2 mm	a mm				ID	ID						
7/16	20	11.11	100	14.0	8.0	6.2	3	9.80		102434	142781						
1/2	20	12.70	100	14.0	9.0	7.0	3	11.40		102430	102503						
9/16	18	14.28	100	14.0	11.0	9.0	3	12.90		102436	143422						
5/8	18	15.87	100	14.0	12.0	9.0	3	14.50		102433	143097						
3/4	16	19.05	125	18.0	14.0	11.0	4	17.50		102432	102505						
7/8	14	22.22	140	20.0	18.0	14.5	4	20.40		102435	144714						
1	12	25.40	160	27.0	18.0	14.5	4	23.30		102431	102504						
1 1/8	12	28.57	180	24.0	22.0	18.0	4	26.50		102429	144414						
1 1/4	12	31.75	180	24.0	22.0	18.0	4	29.70		102428	151709						
1 1/2	12	38.10	200	30.0	32.0	24.0	5	36.00		102427	148793						
$\varnothing'' d_1$ UNF	P TPI	d_1 mm	l_1 mm	l_2 mm	d_2 mm	a mm				ID							
7/16	20	11.11	100	14.0	8.0	6.2	3	10.00		155331							
1/2	20	12.70	100	14.0	9.0	7.0	3	11.55		155322							

UNF

UNF ANSI B1.1

PM

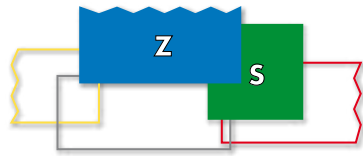
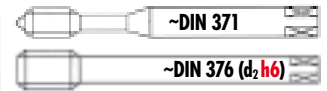

Z370VS-3

Z470VS-3

Z370VS-3

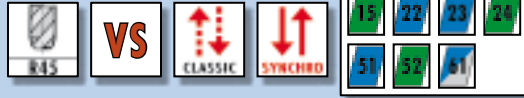

Z470VS-3

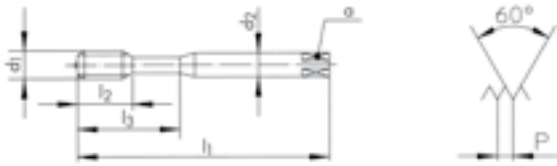
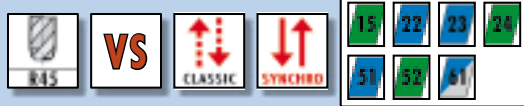

2BX

2BX

Ø" d ₁ UNF	P TPI	d ₁ mm	l ₁ mm	l ₂ mm	l ₃ mm	d ₂ h6 mm	α mm		
10	32	4.82	70	9.0	25	6.0	4.9	3	4.05
1/4	28	6.35	80	11.0	30	*6.0	*4.9	3	5.50
5/16	24	7.93	90	12.5	35	8.0	6.2	3	6.90
3/8	24	9.52	100	14.0	39	10.0	8.0	3	8.50
7/16	20	11.11	100	14.0		8.0	6.2	3	9.80
1/2	20	12.70	110	14.0		*10.0	*8.0	4	11.40

ID

ID

166136

166135

166134

166133

166138

166137

* Norme DC / * DC Norm / * Norma DC

3B
UNF(J)

Ø" d ₁ UNF	P TPI	d ₁ mm	l ₁ mm	l ₂ mm	l ₃ mm	d ₂ h6 mm	α mm		
10	32	4.82	70	9.0	25	6.0	4.9	3	4.15
1/4	28	6.35	80	11.0	30	*6.0	*4.9	3	5.55
5/16	24	7.93	90	12.5	35	8.0	6.2	3	7.00
3/8	24	9.52	100	14.0	39	10.0	8.0	3	8.60

ID

165121

165122

165123

165124

* Norme DC / * DC Norm / * Norma DC

UNF ANSI B1.1

PM

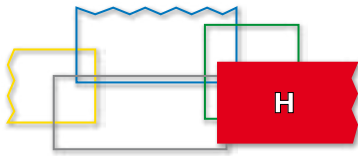
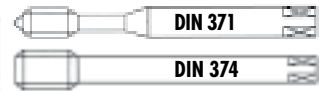

H320-4	H420-4		
--------	--------	--	--

H320-4



H420-4

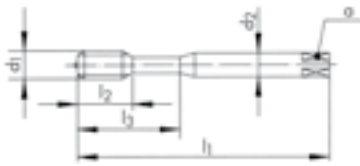

Ø" d ₁ UNF	P TPI	d ₁ mm	l ₁ mm	l ₂ mm	l ₃ mm	d ₂ mm	a mm		
10	32	4.82	70	15.0	25	6.0	4.9	3	4.05
1/4	28	6.35	80	17.0	30	7.0	5.5	3	5.50
5/16	24	7.93	90	20.0	35	8.0	6.2	3	6.90
3/8	24	9.52	100	22.0	39	10.0	8.0	3	8.50
1/2	20	12.70	100	24.0		9.0	7.0	4	11.40

ID	ID
101228	
101227	
105139	
101229	
	101291

UNF ANSI B1.1

PM

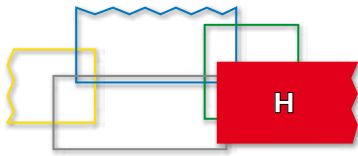
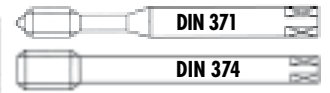

H350-3

H450-3

H350-3



H450-3

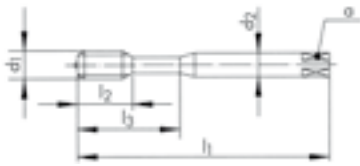

Ø" d ₁ UNF	P TPI	d ₁ mm	l ₁ mm	l ₂ mm	l ₃ mm	d ₂ mm	α mm		
10	32	4.82	70	9.0	25	6.0	4.9	3	4.05
1/4	28	6.35	80	11.0	30	7.0	5.5	3	5.50
5/16	24	7.93	90	12.5	35	8.0	6.2	3	6.90
3/8	24	9.52	100	14.0	39	10.0	8.0	3	8.50
7/16	20	11.11	100	14.0		8.0	6.2	3	9.80
1/2	20	12.70	100	14.0		9.0	7.0	4	11.40
5/8	18	15.87	100	14.0		12.0	9.0	4	14.50
3/4	16	19.05	125	18.0		14.0	11.0	4	17.50

ID

ID

101265

101264

101267

101266

101334

101331

101333

101332

UNF

UNF ANSI B1.1



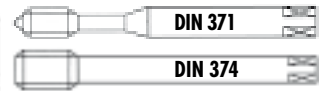















PM

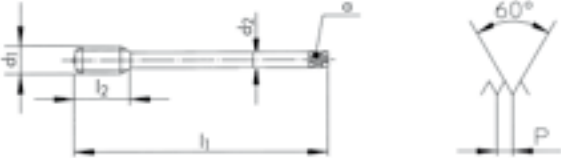

										S320VS-4	S420VS-4	S360VS-3	S460VS-3
S320VS-4		VS											
S420VS-4		VS											
S360VS-3		VS											
S460VS-3		VS											
$\varnothing'' d_1$ UNF	P TPI	d_1 mm	l_1 mm	l_2 mm	l_3 mm	d_2 mm	α mm			ID	ID		
10	32	4.82	70	15.0	25	6.0	4.9	3	4.15	111814			
1/4	28	6.35	80	17.0	30	7.0	5.5	3	5.55	111813			
5/16	24	7.93	90	20.0	35	8.0	6.2	3	7.00	111816			
3/8	24	9.52	100	22.0	39	10.0	8.0	3	8.60	111818			
7/16	20	11.11	100	22.0		8.0	6.2	3	10.00		111837		
$\varnothing'' d_1$ UNF	P TPI	d_1 mm	l_1 mm	l_2 mm	l_3 mm	d_2 mm	α mm			ID	ID		
10	32	4.82	70	9.0	25	6.0	4.9	3	4.05			* 111581	
1/4	28	6.35	80	11.0	30	7.0	5.5	3	5.50			* 111582	
5/16	24	7.93	90	12.5	35	8.0	6.2	3	6.90			* 111583	
7/16	20	11.11	100	14.0		8.0	6.2	3	9.80				* 111585
1/2	20	12.70	100	14.0		9.0	7.0	4	11.40				* 111586
$\varnothing'' d_1$ UNF	P TPI	d_1 mm	l_1 mm	l_2 mm	l_3 mm	d_2 mm	α mm			ID	ID		
10	32	4.82	70	9.0	25	6.0	4.9	3	4.15	111815			
1/4	28	6.35	80	11.0	30	7.0	5.5	3	5.55	111820			
5/16	24	7.93	90	12.5	35	8.0	6.2	3	7.00	111817			
3/8	24	9.52	100	14.0	39	10.0	8.0	3	8.60	111819			
7/16	20	11.11	100	14.0		8.0	6.2	3	10.00		111833		

<h1>aero</h1>										SA320-4	SA350-3	TL320VS-4	TL351VS-3																																																																																				
<div style="display: flex; justify-content: space-between;"> <div style="width: 45%;"> <p>SA320-4 52 53</p> <p>SA350-3 52 53</p> <p>TL320VS-4 VS 41 42</p> <p>TL351VS-3 VS 41 42</p> </div> <div style="width: 50%; text-align: center;"> </div> </div>																																																																																																	
										<div style="display: flex; justify-content: space-around;"> <div style="border: 1px solid black; padding: 5px; text-align: center;">2B</div> <div style="border: 1px solid black; padding: 5px; text-align: center;">2B</div> <div style="border: 1px solid black; padding: 5px; text-align: center;">2B</div> <div style="border: 1px solid black; padding: 5px; text-align: center;">2B</div> </div>																																																																																							
<table border="1" style="width: 100%; border-collapse: collapse;"> <thead> <tr> <th>Ø" d₁ UNF</th> <th>P TPI</th> <th>d₁ mm</th> <th>l₁ mm</th> <th>l₂ mm</th> <th>l₃ mm</th> <th>d₂ mm</th> <th>a mm</th> <th></th> <th></th> </tr> </thead> <tbody> <tr><td>10</td><td>32</td><td>4.82</td><td>70</td><td>15.0</td><td></td><td>6.0</td><td>4.9</td><td>3</td><td>4.05</td></tr> <tr><td>1/4</td><td>28</td><td>6.35</td><td>80</td><td>15.0</td><td>23</td><td>7.0</td><td>5.5</td><td>3</td><td>5.50</td></tr> <tr><td>5/16</td><td>24</td><td>7.93</td><td>90</td><td>18.0</td><td>29</td><td>8.0</td><td>6.2</td><td>3</td><td>6.90</td></tr> <tr><td>3/8</td><td>24</td><td>9.52</td><td>100</td><td>20.0</td><td>33</td><td>10.0</td><td>8.0</td><td>3</td><td>8.50</td></tr> </tbody> </table>										Ø" d ₁ UNF	P TPI	d ₁ mm	l ₁ mm	l ₂ mm	l ₃ mm	d ₂ mm	a mm			10	32	4.82	70	15.0		6.0	4.9	3	4.05	1/4	28	6.35	80	15.0	23	7.0	5.5	3	5.50	5/16	24	7.93	90	18.0	29	8.0	6.2	3	6.90	3/8	24	9.52	100	20.0	33	10.0	8.0	3	8.50	<table border="1" style="width: 100%; border-collapse: collapse;"> <thead> <tr> <th>ID</th> <th>ID</th> <th>ID</th> <th>ID</th> </tr> </thead> <tbody> <tr><td>149133</td><td>149135</td><td>* 152046</td><td>152047</td></tr> <tr><td>149230</td><td>149232</td><td>* 152065</td><td>152066</td></tr> <tr><td>149277</td><td>149279</td><td>* 152071</td><td>152072</td></tr> <tr><td>149339</td><td>149341</td><td>* 152082</td><td>152083</td></tr> </tbody> </table>				ID	ID	ID	ID	149133	149135	* 152046	152047	149230	149232	* 152065	152066	149277	149279	* 152071	152072	149339	149341	* 152082	152083														
Ø" d ₁ UNF	P TPI	d ₁ mm	l ₁ mm	l ₂ mm	l ₃ mm	d ₂ mm	a mm																																																																																										
10	32	4.82	70	15.0		6.0	4.9	3	4.05																																																																																								
1/4	28	6.35	80	15.0	23	7.0	5.5	3	5.50																																																																																								
5/16	24	7.93	90	18.0	29	8.0	6.2	3	6.90																																																																																								
3/8	24	9.52	100	20.0	33	10.0	8.0	3	8.50																																																																																								
ID	ID	ID	ID																																																																																														
149133	149135	* 152046	152047																																																																																														
149230	149232	* 152065	152066																																																																																														
149277	149279	* 152071	152072																																																																																														
149339	149341	* 152082	152083																																																																																														
										<div style="display: flex; justify-content: space-around;"> <div style="border: 1px solid black; padding: 5px; text-align: center;">3B UNF(J)</div> <div style="border: 1px solid black; padding: 5px; text-align: center;">3B UNF(J)</div> <div style="border: 1px solid black; padding: 5px; text-align: center;">3B UNF(J)</div> <div style="border: 1px solid black; padding: 5px; text-align: center;">3B UNF(J)</div> </div>																																																																																							
<table border="1" style="width: 100%; border-collapse: collapse;"> <thead> <tr> <th>Ø" d₁ UNF</th> <th>P TPI</th> <th>d₁ mm</th> <th>l₁ mm</th> <th>l₂ mm</th> <th>l₃ mm</th> <th>d₂ mm</th> <th>a mm</th> <th></th> <th></th> </tr> </thead> <tbody> <tr><td>4</td><td>48</td><td>2.84</td><td>56</td><td>12.0</td><td></td><td>3.5</td><td>2.7</td><td>3</td><td>2.35</td></tr> <tr><td>10</td><td>32</td><td>4.82</td><td>70</td><td>15.0</td><td></td><td>6.0</td><td>4.9</td><td>3</td><td>4.15</td></tr> <tr><td>1/4</td><td>28</td><td>6.35</td><td>80</td><td>15.0</td><td>23</td><td>7.0</td><td>5.5</td><td>3</td><td>5.55</td></tr> <tr><td>5/16</td><td>24</td><td>7.93</td><td>90</td><td>18.0</td><td>29</td><td>8.0</td><td>6.2</td><td>3</td><td>7.00</td></tr> <tr><td>3/8</td><td>24</td><td>9.52</td><td>100</td><td>20.0</td><td>33</td><td>10.0</td><td>8.0</td><td>3</td><td>8.60</td></tr> </tbody> </table>										Ø" d ₁ UNF	P TPI	d ₁ mm	l ₁ mm	l ₂ mm	l ₃ mm	d ₂ mm	a mm			4	48	2.84	56	12.0		3.5	2.7	3	2.35	10	32	4.82	70	15.0		6.0	4.9	3	4.15	1/4	28	6.35	80	15.0	23	7.0	5.5	3	5.55	5/16	24	7.93	90	18.0	29	8.0	6.2	3	7.00	3/8	24	9.52	100	20.0	33	10.0	8.0	3	8.60	<table border="1" style="width: 100%; border-collapse: collapse;"> <thead> <tr> <th>ID</th> <th>ID</th> <th>ID</th> <th>ID</th> </tr> </thead> <tbody> <tr><td></td><td>149015</td><td></td><td></td></tr> <tr><td>146098</td><td>149138</td><td>* 148005</td><td>148004</td></tr> <tr><td>146404</td><td>149235</td><td>* 148013</td><td>148012</td></tr> <tr><td>146393</td><td>149282</td><td>* 148017</td><td>148016</td></tr> <tr><td>147165</td><td>149344</td><td>* 148024</td><td>148023</td></tr> </tbody> </table>				ID	ID	ID	ID		149015			146098	149138	* 148005	148004	146404	149235	* 148013	148012	146393	149282	* 148017	148016	147165	149344	* 148024	148023
Ø" d ₁ UNF	P TPI	d ₁ mm	l ₁ mm	l ₂ mm	l ₃ mm	d ₂ mm	a mm																																																																																										
4	48	2.84	56	12.0		3.5	2.7	3	2.35																																																																																								
10	32	4.82	70	15.0		6.0	4.9	3	4.15																																																																																								
1/4	28	6.35	80	15.0	23	7.0	5.5	3	5.55																																																																																								
5/16	24	7.93	90	18.0	29	8.0	6.2	3	7.00																																																																																								
3/8	24	9.52	100	20.0	33	10.0	8.0	3	8.60																																																																																								
ID	ID	ID	ID																																																																																														
	149015																																																																																																
146098	149138	* 148005	148004																																																																																														
146404	149235	* 148013	148012																																																																																														
146393	149282	* 148017	148016																																																																																														
147165	149344	* 148024	148023																																																																																														

aero

										SA420-4	SA450-3	TL420VS-4	TL451VS-3
<p>SA420-4  </p> <p>SA450-3  </p>													
<p>TL420VS-4  VS </p> <p>TL451VS-3   VS </p>													
													
													
\varnothing d ₁ UNF	P TPI	d ₁ mm	l ₁ mm	l ₂ mm	d ₂ mm	a mm				ID	ID	ID	
7/16	20	11.11	100	22.0	8.0	6.2	* 4	9.80		152286	152290	* 152298	
1/2	20	12.70	100	24.0	9.0	7.0	4	11.40		152287	152291	* 152299	
9/16	18	14.28	100	24.0	11.0	9.0	4	12.90		* 152288			
5/8	18	15.87	100	26.0	12.0	9.0	4	14.50		* 152289			
													
\varnothing d ₁ UNF	P TPI	d ₁ mm	l ₁ mm	l ₂ mm	d ₂ mm	a mm			UNF	ID	ID	ID	ID
7/16	20	11.11	100	22.0	8.0	6.2	* 4	10.00		147187	152302	* 152306	148031
1/2	20	12.70	100	24.0	9.0	7.0	4	11.55		147189	152303	* 152307	152310
9/16	18	14.28	100	24.0	11.0	9.0	4	13.05		146395			
5/8	18	15.87	100	26.0	12.0	9.0	4	14.60		147169			

* SA420-4 =  3

* TL420VS-4 =  3

UNJF ASME B1.15 UNF ANSI B1.1

PM

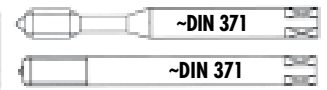

aero

SA320-4



SA390-3



SA320-4

SA390-3



NEW



3B UNJF

3B UNF(J)

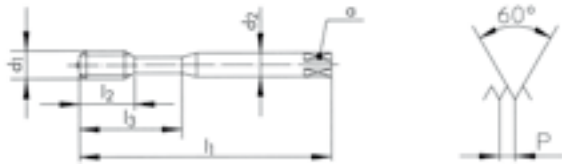

\varnothing d ₁ UNJF	P TPI	d ₁ mm	l ₁ mm	l ₂ mm	l ₃ mm	d ₂ mm	α mm			ID
10	32	4.82	70	15.0		6.0	4.9	3	4.15	174976
1/4	28	6.35	80	15.0	23	7.0	5.5	3	5.55	175993
5/16	24	7.93	90	18.0	29	8.0	6.2	3	7.00	175995
3/8	24	9.52	100	20.0	33	10.0	8.0	3	8.60	175997

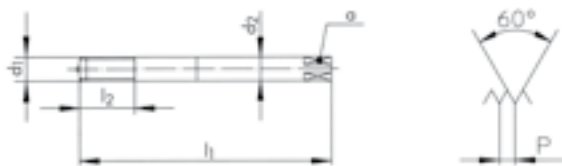

\varnothing d ₁ UNF	P TPI	d ₁ mm	l ₁ mm	l ₂ mm	d ₂ mm	α mm			ID
10	32	4.82	70	15.0	6.0	4.9	3	4.15	149687
1/4	28	6.35	80	20.0	7.0	5.5	3	5.55	149715
5/16	24	7.93	90	25.0	8.0	6.2	3	7.00	149728
3/8	24	9.52	100	30.0	10.0	8.0	3	8.60	149745

UNF

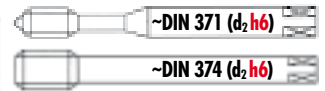

RTS Rigid Tapping Synchro

RTS320VS-4

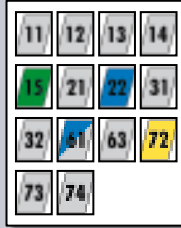

RTS420VS-4



RTS362VS-3

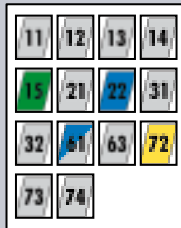

RTS462VS-3



RTS320VS-4

RTS420VS-4

RTS362VS-3

RTS462VS-3

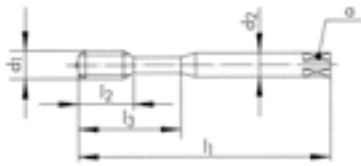

Ø" d ₁ UNF	P TPI	d ₁ mm	l ₁ mm	l ₂ mm	l ₃ mm	d ₂ h6 mm	α mm		
10	32	4.82	70	9.0	25	6.0	4.9	3	4.05
1/4	28	6.35	80	11.0	30	*6.0	*4.9	3	5.50
5/16	24	7.93	90	12.5	35	8.0	6.2	3	6.90
3/8	24	9.52	100	14.0	39	10.0	8.0	3	8.50
1/2	20	12.70	110	14.0		*10.0	*8.0	3	11.40

ID

ID

ID

ID

157409

157413

157410

157414

157411

157415

157412

157416

157417

157418

* Norme DC / * DC Norm / * Norma DC



sur demande
auf Anfrage
on request
su richiesta
sobre pedido

FS FPS FAS FORMING

FS380VS-5

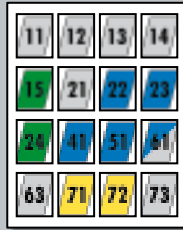

FPS381VS-3

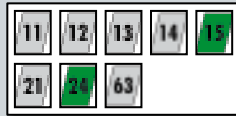

FAS381VS-3

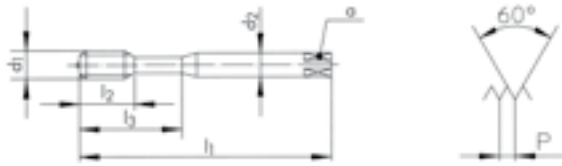

FS380VS-5



FPS381VS-3



FAS381VS-3



2BX

2BX

2BX

\varnothing d ₁ UNF	P TPI	d ₁ mm	l ₁ mm	l ₂ mm	l ₃ mm	d ₂ mm	α mm	$\frac{d_2}{P}$	Tol.
0	80	1.52	40	4.6		2.5	1.37	+ 0.02	
10	32	4.82	70	15.0	25	6.0	4.9	+ 0.03	
1/4	28	6.35	80	17.0	30	7.0	5.5	+ 0.05	
5/16	24	7.93	90	20.0	35	8.0	6.2	+ 0.05	

ID

161498

ID

166718

ID

166730

166719

166731

166720

166732







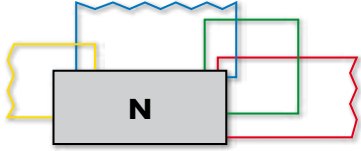

UNF ANSI B1.1

≤ Ø 2.8 > Ø 2.8

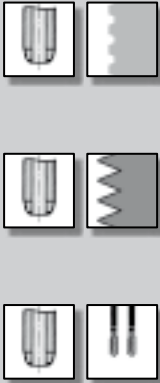
PM **HSS**

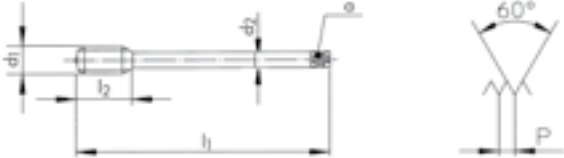

										N1110-1	N1110-3	N1110-S	
N1110-1													
N1110-3													
N1110-S													
Ø" d ₁ UNF	P TPI	d ₁ mm	l ₁ mm	l ₂ mm	l ₃ mm	d ₂ mm	a mm			ID	ID	ID	
0	80	1.52	40	7.0		2.50	2.10	3	1.20	102811	103010	111079	
1	72	1.85	40	8.0		2.50	2.10	3	1.50	102812	103011	111080	
4	48	2.84	48	11.0	18	3.15	2.50	3	2.35		* 103018		
8	36	4.16	53	13.0	21	4.50	3.55	3	3.50		* 103022		
10	32	4.82	58	16.0	25	5.00	4.00	3	4.05	102814	103013	111082	
12	28	5.48	62	17.0	26	5.60	4.50	3	4.60	* 102815	* 103014	* 111083	
1/4	28	6.35	66	19.0	30	6.30	5.00	3	5.50	102813	103012	111081	
5/16	24	7.93	72	22.0	35	8.00	6.30	3	6.90	102821	103020	111089	
3/8	24	9.52	80	24.0	39	10.00	8.00	3	8.50	102818	103017	111086	

										N1210-1	N1210-3	N1210-S							
																			
																			
																			
																			
\varnothing d ₁ UNF	P TPI	d ₁ mm	l ₁ mm	l ₂ mm	d ₂ mm	a mm				ID	ID	ID							
7/16	20	11.11	85	22.0	8.0	6.3	3	9.80		103411	103626	111255							
1/2	20	12.70	89	24.0	9.0	7.1	3	11.40		103407	103622	111251							
5/8	18	15.87	102	32.0	12.5	10.0	3	14.50		103410	103625	111254							
3/4	16	19.05	112	33.0	14.0	11.2	4	17.50		103409	103624	111253							
7/8	14	22.22	115	32.0	16.0	12.5	4	20.40		103412	103627	111256							
1	12	25.40	130	45.0	18.0	14.0	4	23.30		103408	103623	111252							

UNF

										N1110-3	N1120-4	N1210-3	N1220-4
N1110-3													
N1120-4													
N1210-3													
N1220-4													
\varnothing d ₁ UNEF	P TPI	d ₁ mm	l ₁ mm	l ₂ mm	l ₃ mm	d ₂ mm	a mm			ID	ID	ID	ID
12	32	5.48	62	17.0	26	5.6	4.5	3	4.70	103007	103118		
1/4	32	6.35	66	19.0	30	6.3	5.0	3	5.60	103006	103117		
5/16	32	7.93	72	22.0	35	8.0	6.3	3	7.20	103009	103120		
3/8	32	9.52	80	24.0	39	10.0	8.0	3	8.75	103008	103119		
7/16	28	11.11	85	22.0		8.0	6.3	3	10.25			103615	103754
1/2	28	12.70	89	24.0		9.0	7.1	3	11.85			103609	103749
9/16	24	14.28	95	24.0		11.2	9.0	3	13.20			103617	103756
5/8	24	15.87	102	32.0		12.5	10.0	3	14.80			103614	103753
11/16	24	17.46	104	26.0		14.0	11.2	4	16.40			103611	
3/4	20	19.05	112	33.0		14.0	11.2	4	17.80			103613	* 103752
7/8	20	22.22	115	32.0		16.0	12.5	4	21.00			103616	* 103755
1	20	25.40	120	30.0		18.0	14.0	4	24.10			103610	* 103750

UNS, UN ANSI B1.1

HSSE











										N410-3	N460-3	N460V-3	
N410-3													
N460-3													
N460V-3													
\varnothing d ₁	P	d ₁	l ₁	l ₂	d ₂	a				ID	ID	ID	
UNS	TPI	mm	mm	mm	mm	mm							
1/4	36	6.35	80	17.0	4.5	3.4	3	5.65	104899				
1/2	24	12.70	100	24.0	9.0	7.0	3	11.60	104900				
1	14	25.40	140	34.0	18.0	14.5	4	23.60	104898				
1	14	25.40	140	22.0	18.0	14.5	4	23.60		102437	142789		
\varnothing d ₁	P	d ₁	l ₁	l ₂	d ₂	a				ID	ID		
UN	TPI	mm	mm	mm	mm	mm							
1 1/8	8	28.57	180	30.0	22.0	18.0	4	25.50		102415	142790		
1 1/4	8	31.75	180	30.0	22.0	18.0	4	28.70		102414	142520		
1 3/8	8	34.92	200	36.0	28.0	22.0	5	31.80		104896	142792		
1 1/2	8	38.10	200	40.0	32.0	24.0	5	35.00		102413	142793		
1 3/4	8	44.45	220	44.0	36.0	29.0	5	41.40			115198		
2	8	50.80	250	38.0	40.0	32.0	5	47.70			111622		

UNF, UNS, UN

G Inhaltsverzeichnis - Maschinengewindebohrer G (Rohr) DIN ISO 228

Directory - Machine taps G (BSP) DIN ISO 228

		N					
Merkmale Characteristics			 V	 TiN	 R40	 R40 V	 R40 TiN
			 				
Lochart Hole type							
							
		N410-3	N420-4 N420V-4	N420TN-4	N460-3	N460V-3	N462V-3 N460TN-3
DIN lang DIN long	DIN 5156	156	157	157	158	158	158
DIN kurz DIN short	DIN 5157						
LH Linksgewinde LH Left hand thread	DIN 5156	156					





















G Inhaltsverzeichnis - Maschinen- und Handgewindebohrer G (Rohr) DIN ISO 228 Directory - Machine and hand taps G (BSP) DIN ISO 228

N			W		Z			
N210-1	N210-3	N210-S	W460-5	W460DL-5	Z420V-4	Z420VS-4	Z460V-3	Z470VS-3
163	163	163	159	159	160	160	160	161























G (BSP),
Rp, Rc, W

G Inhaltsverzeichnis - Maschinengewindebohrer und Gewindeformer G (Rohr) DIN ISO 228











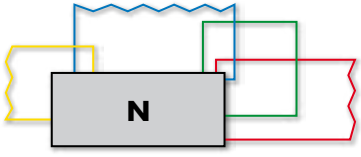

Directory - Machine taps and thread formers G (BSP) DIN ISO 228

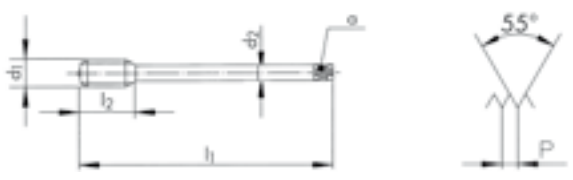
	H	GG	RTS	RTS	FPS	FAS	
Merkmale Characteristics		 NV	 VS	 E 1.5 x P VS	 VS	 VS	
							
Lochart Hole type							
							
	H450-3	GG450NV-3	RTS462VS-3	RTS462VS-5	FPS481VS-3	FAS481VS-3	
<i>DIN lang</i> DIN long	DIN 5156	159	159				
<i>DIN lang</i> DIN long	~DIN 376		161	161			
<i>DIN lang</i> DIN long	~DIN 2189				162	162	











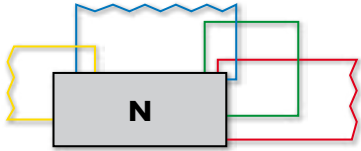





Rp, Rc DIN EN 10226, **W** BS 84 (BSW) *Inhaltsverzeichnis - Maschinen- und Handgewindebohrer*
W/SV Schaublin *Directory - Machine and hand taps*

		N						
Merkmale Characteristics							HSS	
								
								
Lochart Hole type								
					N1110-3	N1120-4	N5120	
ISO kurz ISO short	ISO 529				166	166		
W	ISO 529				166/167	166		
SV	ISO 529				167			
		N420-3	N410-3	D5800	N1210-3	N1220-4		
DIN lang DIN long	DIN 5156	164						
DIN lang DIN long	DC		164	165				
ISO kurz ISO short	ISO 529				166	166		
Rp	DIN 5156	164						
Rc	DC		164	165				
W	ISO 529				166	166		
SV	ISO 529/DC				167		167	

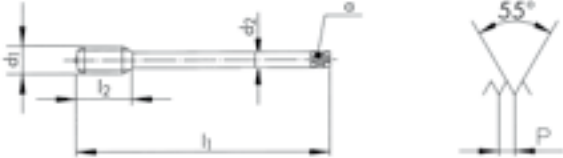
G (BSP),
Rp, Rc, W, SV

										N410-3		N410-3 LH					
																	
																	
																	
\varnothing G	d_1	P	d_1	l_1	l_2	d_2	α			ID	ID						
		TPI	mm	mm	mm	mm	mm										
1/8	28	9.72	90	22.0	7.0	5.5	3	8.75	101855								
1/4	19	13.15	100	20.0	11.0	9.0	3	11.60	101853	101854							
3/8	19	16.66	100	20.0	12.0	9.0	4	15.20	101861	101862							
1/2	14	20.95	125	22.0	16.0	12.0	4	18.90	101851	101852							
3/4	14	26.44	140	28.0	20.0	16.0	4	24.40	101859	* 101860							
1	11	33.24	160	32.0	25.0	20.0	4	30.70	101857	* 101858							
1 1/4	11	41.91	170	32.0	32.0	24.0	5	39.30	101850								
1 1/2	11	47.80	190	32.0	36.0	29.0	5	45.20	101849								

G DIN ISO 228 (BSP)

										N420-4	N420V-4	N420TN-4	
										<p>N420-4  </p> <p>N420V-4  V </p> <p>N420TN-4  TiN </p>			
													
													
$\frac{\text{Ø}''}{\text{G}}$ d_1	P	d_1	l_1	l_2	d_2	α				ID	ID	ID	
	TPI	mm	mm	mm	mm	mm							
1/16	28	7.72	90	18.0	6.0	4.9	3	6.75		102045			
1/8	28	9.72	90	22.0	7.0	5.5	3	8.75		102048	102258	102236	
1/4	19	13.15	100	20.0	11.0	9.0	3	11.60		102047	102257	102235	
3/8	19	16.66	100	20.0	12.0	9.0	3	15.20		102053	102261	102238	
1/2	14	20.95	125	22.0	16.0	12.0	4	18.90		102046	102256	102234	
5/8	14	22.91	125	25.0	18.0	14.5	4	20.90		102054	144722		
3/4	14	26.44	140	28.0	20.0	16.0	4	24.40		102052	102260	102237	
1	11	33.24	160	32.0	25.0	20.0	4	30.70		102049	102259		
1 1/4	11	41.91	170	32.0	32.0	24.0	5	39.30		102043			
1 1/2	11	47.80	190	32.0	36.0	29.0	5	45.20		102042			
2	11	59.61	220	36.0	45.0	35.0	5	57.00		102051			
2 1/2	11	75.18	280	36.0	50.0	39.0	6	72.60		102050			

G DIN ISO 228 (BSP)

HSSE



										N460-3	N460V-3	N460TN-3	N462V-3	
N460-3														
N460V-3														
N460TN-3														
N462V-3														
$\frac{\text{Ø}''}{G}$ d_1	P	d_1	l_1	l_2	d_2	α			ID	ID	ID	ID		
	TPI	mm	mm	mm	mm	mm								
1/16	28	7.72	90	12.5	6.0	4.9	3	6.75	102341					
1/8	28	9.72	90	14.0	7.0	5.5	3	8.75	102344	102457	102444	143687		
1/4	19	13.15	100	14.0	11.0	9.0	3	11.60	102343	102456	102443	143600		
3/8	19	16.66	100	14.0	12.0	9.0	4	15.20	102348	102460	102446	143431		
1/2	14	20.95	125	20.0	16.0	12.0	4	18.90	102342	102455	102442	143921		
5/8	14	22.91	125	20.0	18.0	14.5	4	20.90	102349	143711				
3/4	14	26.44	140	22.0	20.0	16.0	4	24.40	102347	102459	102445	143688		
1	11	33.24	160	26.0	25.0	20.0	4	30.70	102345	102458				
1 1/4	11	41.91	170	30.0	32.0	24.0	5	39.30	102340	111608				
1 1/2	11	47.80	190	35.0	36.0	29.0	5	45.20	102339	111609				
2	11	59.61	220	41.0	45.0	35.0	6	57.00	102346	111503				

G DIN ISO 228 (BSP)

≤ Ø 25.4 > Ø 25.4

PM

HSSE

HSSE

H/GG

H/GG

W

DIN 5156

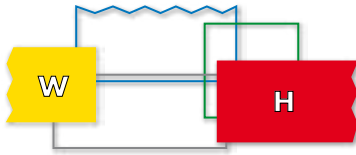

W460-5

W460DL-5

H450-3

GG450NV-3

W460-5



W460DL-5



H450-3



GG450NV-3



NEW

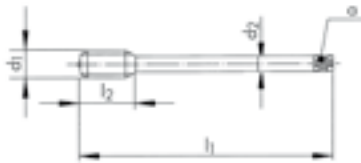

Ø" d ₁ G	P TPI	d ₁ mm	l ₁ mm	l ₂ mm	d ₂ mm	a mm		
1/8	28	9.72	90	14.0	7.0	5.5	3	8.75
1/4	19	13.15	100	14.0	11.0	9.0	*4	11.60
3/8	19	16.66	100	14.0	12.0	9.0	4	15.20
1/2	14	20.95	125	20.0	16.0	12.0	4	18.90
3/4	14	26.44	140	22.0	20.0	16.0	4	24.40
1	11	33.24	160	26.0	25.0	20.0	4	30.70

* W460-5 = 3

Ø" d ₁ G	P TPI	d ₁ mm	l ₁ mm	l ₂ mm	d ₂ mm	a mm			ID
1/8	28	9.72	90	22.0	7.0	5.5	4	8.75	102309
1/4	19	13.15	100	20.0	11.0	9.0	4	11.60	102308
3/8	19	16.66	100	20.0	12.0	9.0	4	15.20	102312
1/2	14	20.95	125	22.0	16.0	12.0	4	18.90	102307
3/4	14	26.44	140	28.0	20.0	16.0	4	24.40	102311
1	11	33.24	160	32.0	25.0	20.0	4	30.70	102310

G DIN ISO 228 (BSP)

< Ø 25.4 > Ø 25.4

PM
Z420

HSSE
Z420

HSSE
Z460

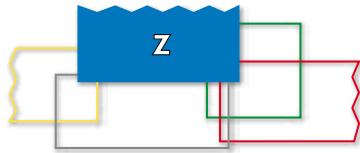

Z420V-4		V	21 22 23 41 42 51
Z420VS-4		VS	21 22 23 24 51 61
Z460V-3		V	22 23 51

Z420V-4	Z420VS-4	Z460V-3	
----------------	-----------------	----------------	--

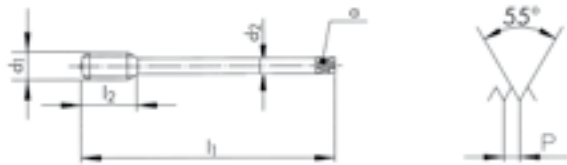
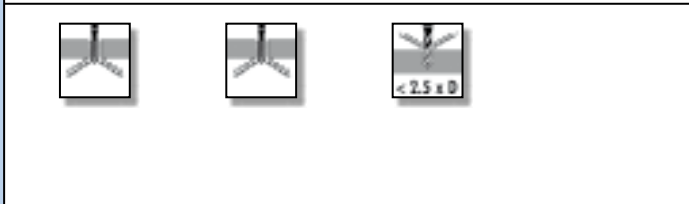

Ø" d ₁ G	P TPI	d ₁ mm	l ₁ mm	l ₂ mm	d ₂ mm	α mm		
1/8	28	9.72	90	22.0	7.0	5.5	3	8.75
1/4	19	13.15	100	20.0	11.0	9.0	3	11.60
3/8	19	16.66	100	20.0	12.0	9.0	3	15.20
1/2	14	20.95	125	22.0	16.0	12.0	4	18.90
3/4	14	26.44	140	28.0	20.0	16.0	4	24.40
1	11	33.24	160	32.0	25.0	20.0	4	30.70

ID	ID
142794	142800
142795	119303
142796	142802
142797	142803
142798	
142799	

Ø" d ₁ G	P TPI	d ₁ mm	l ₁ mm	l ₂ mm	d ₂ mm	α mm		
1/8	28	9.72	90	14.0	7.0	5.5	3	8.75
1/4	19	13.15	100	14.0	11.0	9.0	3	11.60
3/8	19	16.66	100	14.0	12.0	9.0	4	15.20
1/2	14	20.95	125	20.0	16.0	12.0	4	18.90
3/4	14	26.44	140	22.0	20.0	16.0	4	24.40
1	11	33.24	160	26.0	25.0	20.0	4	30.70

ID
104726
104725
104728
104724
104727
105142



Uniquement pour taraudage synchrone
Nur für Synchrobearbeitung
Only for rigid tapping
Solo per maschiatura sincrona
Solo para roscado sincronizado

PM

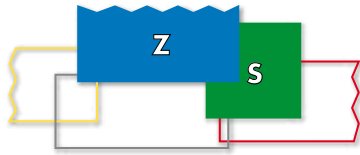

Z470VS-3

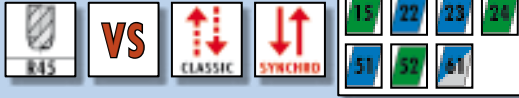

RTS

Rigid Tapping Synchro

RTS462VS-3

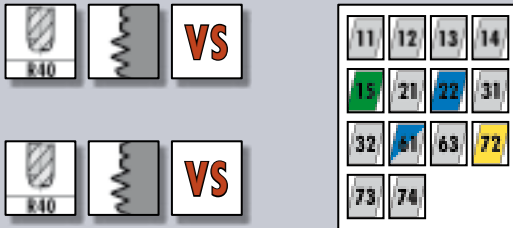

RTS462VS-5

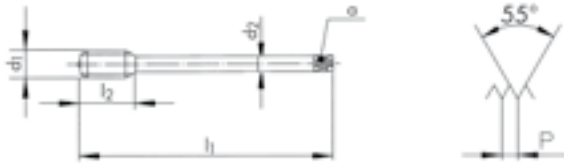

Z470VS-3



RTS462VS-3



RTS462VS-5



$\varnothing'' d_1$ G	P TPI	d_1 mm	l_1 mm	l_2 mm	$d_2 h6$ mm	α mm			ID
1/8	28	9.72	100	14.0	*8.0	*6.2	3	8.75	165198
1/4	19	13.15	110	14.0	*12.0	*9.0	4	11.60	165199
3/8	19	16.66	110	18.0	12.0	9.0	4	15.20	165200
1/2	14	20.95	125	20.0	16.0	12.0	4	18.90	165201











* Norme DC / * DC Norm / * Norma DC





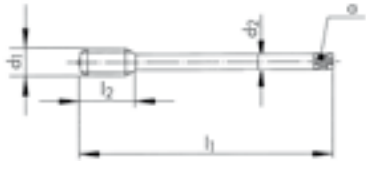

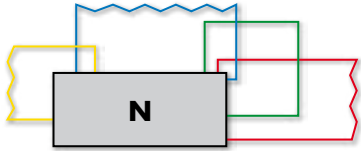
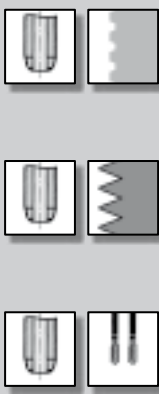
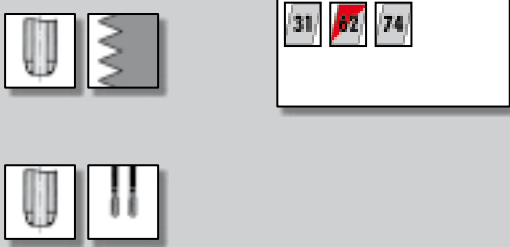

$\varnothing'' d_1$ G	P TPI	d_1 mm	l_1 mm	l_2 mm	$d_2 h6$ mm	α mm			ID	ID
1/8	28	9.72	100	14.0	*8.0	*6.2	3	8.75	151861	170629
1/4	19	13.15	110	14.0	*12.0	*9.0	3	11.60	151868	170631
3/8	19	16.66	110	18.0	12.0	9.0	4	15.20	151872	170633
1/2	14	20.95	125	20.0	16.0	12.0	4	18.90	150685	170635

* Norme DC / * DC Norm / * Norma DC

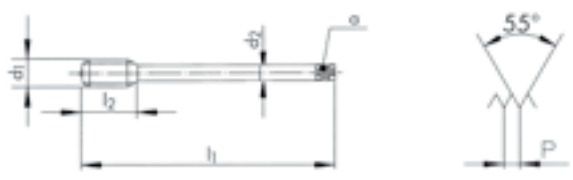

sur demande
auf Anfrage
on request
su richiesta
sobre pedido

FPS FAS		FORMING		FPS481VS-3	FAS481VS-3												
FPS481VS-3		VS	<table border="1"> <tr> <td>11</td> <td>12</td> <td>13</td> <td>14</td> <td>15</td> </tr> <tr> <td>21</td> <td>24</td> <td>63</td> <td></td> <td></td> </tr> </table>	11	12	13	14	15	21	24	63						
11	12	13	14	15													
21	24	63															
FAS481VS-3		VS	<table border="1"> <tr> <td>12</td> <td>13</td> <td>14</td> <td>15</td> <td>21</td> <td>22</td> </tr> <tr> <td>23</td> <td>24</td> <td>41</td> <td>51</td> <td>61</td> <td>63</td> </tr> </table>	12	13	14	15	21	22	23	24	41	51	61	63		
12	13	14	15	21	22												
23	24	41	51	61	63												
 																	
\varnothing d ₁ G	P TPI	d ₁ mm	l ₁ mm	l ₂ mm	d ₂ mm	α mm	\pm → ←	Tol.	ID	ID							
1/8	28	9.72	90	22.0	7.0	5.5	9.25	+ 0.05	166721	166733							
1/4	19	13.15	100	20.0	11.0	9.0	12.50	+ 0.05	166722	166734							
3/8	19	16.66	100	20.0	12.0	9.0	16.00	+ 0.05	166723	166735							
1/2	14	20.95	125	22.0	16.0	12.0	20.00	+ 0.05	166724	166736							

										N210-1	N210-3	N210-S
												
												
												
												
\varnothing d ₁ G	P TPI	d ₁ mm	l ₁ mm	l ₂ mm	d ₂ mm	a mm				ID	ID	ID
1/16	28	7.72	63	18.0	6.0	4.9	3	6.75			101418	
1/8	28	9.72	63	22.0	7.0	5.5	3	8.75	101404	101421	119386	
1/4	19	13.15	70	20.0	11.0	9.0	3	11.60	101403	101420	119336	
3/8	19	16.66	70	20.0	12.0	9.0	4	15.20	101409	101427	110938	
1/2	14	20.95	80	22.0	16.0	12.0	4	18.90	101402	101419	119264	
5/8	14	22.91	80	25.0	18.0	14.5	4	20.90	101411	105140	110940	
3/4	14	26.44	90	28.0	20.0	16.0	4	24.40	101408	101426	110937	
7/8	14	30.20	90	28.0	22.0	18.0	4	28.20	* 101412	* 101429		
1	11	33.24	100	32.0	25.0	20.0	4	30.70	101405	101422	110933	
1 1/8	11	37.89	125	32.0	28.0	22.0	4	35.30		101415		
1 1/4	11	41.91	125	32.0	32.0	24.0	5	39.30	101400	101414	111425	
1 3/8	11	44.32	125	32.0	36.0	29.0	5	41.80		* 101417		
1 1/2	11	47.80	140	32.0	36.0	29.0	5	45.20	101399	101413	110934	
1 3/4	11	53.74	140	36.0	40.0	32.0	5	51.20		* 101416		
2	11	59.61	160	36.0	45.0	35.0	5	57.00	101407	101425	110935	
2 1/2	11	75.18	160	36.0	50.0	39.0	6	72.60		101423		
3	11	87.88	160	40.0	50.0	39.0	6	85.30		* 101428		

G, Rp, Rc

Rp, Rc DIN EN 10226

HSSE

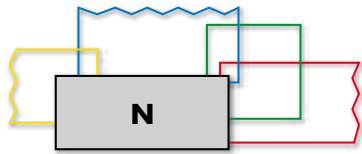
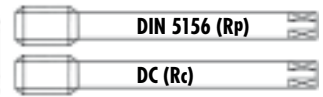

N420-3

N410-3

N420-3





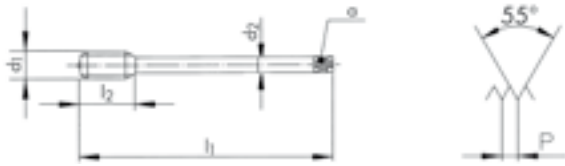

N410-3

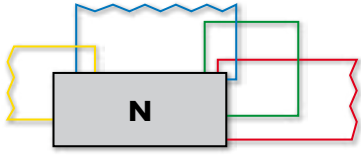

$\varnothing'' d_1$ Rp	P TPI	d_1 mm	l_1 mm	l_2 mm	d_2 mm	α mm			ID
1/8	28	9.72	90	22.0	7.0	5.5	3	8.60	104911
1/4	19	13.15	100	20.0	11.0	9.0	3	11.50	104912
3/8	19	16.66	100	20.0	12.0	9.0	3	15.00	104913
1/2	14	20.95	125	22.0	16.0	12.0	4	18.50	104914
3/4	14	26.44	140	28.0	20.0	16.0	4	24.00	104915
1	11	33.24	160	32.0	25.0	20.0	4	30.25	104916

$\varnothing'' d_1$ Rc	P TPI	d_1 mm	l_1 mm	l_2 mm	d_2 mm	α mm		ID
1/8	28	9.72	71	13.0	8.0	6.2	5	104917
1/4	19	13.15	80	20.0	11.0	9.0	5	104918
3/8	19	16.66	90	20.0	12.0	9.0	5	104919
1/2	14	20.95	100	26.0	16.0	12.0	5	104920
3/4	14	26.44	110	26.0	20.0	16.0	5	104921
1	11	33.24	125	32.0	25.0	20.0	5	104922

Rc	Vc (m/min) Ø d1			
	1/16" - 1/4"	3/8" - 1/2"	3/4" - 1"	1.1/4" - 2"
	10	8	7	5
	18	15	13	10

					D5800			
D5800 								
								
\varnothing'' Rc	l_1 mm	l_2 mm	d_2 mm	α mm	ID			
1/16	70	17.0	6.0	4.9	118701			
1/8	70	17.0	8.0	6.2	110531			
1/4	80	27.0	10.0	8.0	110530			
3/8	85	27.0	12.0	9.0	110535			
1/2	95	35.0	16.0	12.0	110529			
3/4	105	35.0	20.0	16.0	110534			
1	130	43.0	25.0	20.0	110532			

Kernloch-Durchmesser für kegeliges Rohrgewinde nach DIN EN 10226 Core hole diameters for tapered pipe thread to DIN EN 10226

Bohrung zylindrisch
Vermeiden, da schnellere Abnutzung des Gewindebohrers und Klemmen

Parallel hole
Increased tap wear, not recommended

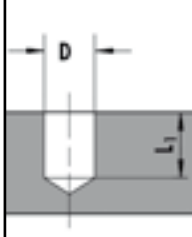

Bohrung konisch 1:16
Zylindrisch bohren nach $\varnothing D_2$ und konisch aufreiben auf $\varnothing D_3$

Tapered hole 1:16
Pre-drill at $\varnothing D_2$ and taper-ream to $\varnothing D_3$

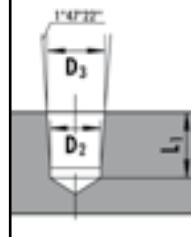

Gewindeschneiden
Gewindebohrer auf Nennmass L_2 eindrehen

Tapped hole
Engage tap to hole depth $L_2 = \text{nominal } \varnothing$

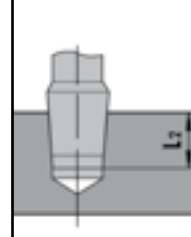

\varnothing'' Rc	L_1 min. mm	D_1 mm	D_2 mm	D_3 mm	L_2 mm
1/16	11.90	6.20	6.10	6.56	10.60
1/8	11.90	8.20	8.10	8.57	10.60
1/4	17.70	11.00	10.75	11.45	15.70
3/8	18.10	14.50	14.25	14.95	16.10
1/2	24.00	18.00	17.75	18.63	21.40
3/4	25.30	23.50	23.00	24.12	21.50
1	30.60	29.50	29.00	30.29	26.30

W BS 84 (BSW)

HSS

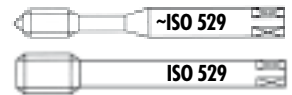











										N1110-3	N1210-3	N1120-4	N1220-4	
N1110-3														
N1210-3														
N1120-4														
N1220-4														
\varnothing W	d_1	P	d_1	l_1	l_2	l_3	d_2	a			ID	ID	ID	ID
1/8	40	3.17	48	11.0	18	3.15	2.50	3	2.50		103025		103126	
5/32	32	3.96	53	13.0	21	4.00	3.15	3	3.10		103031		103130	
3/16	24	4.76	58	16.0	25	5.00	4.00	3	3.60		103026		103127	
1/4	20	6.35	66	19.0	30	6.30	5.00	3	4.90		103024		103125	
5/16	18	7.93	72	22.0	35	8.00	6.30	3	6.40		103030		103129	
3/8	16	9.52	80	24.0	39	10.00	8.00	3	7.70		103028		103128	
7/16	14	11.11	85	22.0		8.00	6.30	3	9.10			103642		103771
1/2	12	12.70	89	24.0		9.00	7.10	3	10.30			103634		103767
9/16	12	14.28	95	24.0		11.20	9.00	3	11.90			* 103644		
5/8	11	15.87	102	32.0		12.50	10.00	3	13.30			103641		103770
3/4	10	19.05	112	33.0		14.00	11.20	3	16.20			103640		103769
1	8	25.40	130	45.0		18.00	14.00	4	21.90			* 103635		

		N1110-3		N1210-3		N5120																																																																																
N1110-3																																																																																						
N1210-3																																																																																						
N5120																																																																																						
<table border="1"> <thead> <tr> <th>$\varnothing d_1$</th> <th>P</th> <th>l_1</th> <th>l_2</th> <th>l_3</th> <th>d_2</th> <th>a</th> <th></th> <th></th> <th>ID</th> </tr> <tr> <th>W</th> <th>TPI/mm</th> <th>mm</th> <th>mm</th> <th>mm</th> <th>mm</th> <th>mm</th> <th></th> <th></th> <th></th> </tr> </thead> <tbody> <tr> <td>5</td> <td>36 TPI/1"</td> <td>B6</td> <td>58</td> <td>16.0</td> <td>25</td> <td>5.0</td> <td>4.0</td> <td>3</td> <td>4.20*</td> </tr> <tr> <td>6.82</td> <td>0.625</td> <td>B8</td> <td>66</td> <td>19.0</td> <td>30</td> <td>7.1</td> <td>5.6</td> <td>3</td> <td>6.15*</td> </tr> </tbody> </table>										$\varnothing d_1$	P	l_1	l_2	l_3	d_2	a			ID	W	TPI/mm	mm	mm	mm	mm	mm				5	36 TPI/1"	B6	58	16.0	25	5.0	4.0	3	4.20*	6.82	0.625	B8	66	19.0	30	7.1	5.6	3	6.15*																																					
$\varnothing d_1$	P	l_1	l_2	l_3	d_2	a			ID																																																																													
W	TPI/mm	mm	mm	mm	mm	mm																																																																																
5	36 TPI/1"	B6	58	16.0	25	5.0	4.0	3	4.20*																																																																													
6.82	0.625	B8	66	19.0	30	7.1	5.6	3	6.15*																																																																													
<table border="1"> <thead> <tr> <th>$\varnothing d_1$</th> <th>P</th> <th>l_1</th> <th>l_2</th> <th>l_3</th> <th>d_2</th> <th>a</th> <th></th> <th></th> <th>ID</th> <th>ID</th> </tr> <tr> <th>SV</th> <th>mm</th> <th>mm</th> <th>mm</th> <th>mm</th> <th>mm</th> <th>mm</th> <th></th> <th></th> <th></th> <th></th> </tr> </thead> <tbody> <tr> <td>10</td> <td>0.833</td> <td>W10</td> <td>80</td> <td>24.0</td> <td>39</td> <td>10.0</td> <td>8.0</td> <td>3</td> <td>8.80*</td> <td>130429</td> </tr> <tr> <td>12</td> <td>1.250</td> <td>W12</td> <td>89</td> <td>24.0</td> <td></td> <td>9.0</td> <td>7.1</td> <td>3</td> <td>10.50*</td> <td>103591</td> </tr> <tr> <td>15</td> <td>1.250</td> <td>W15</td> <td>90</td> <td>23.0</td> <td></td> <td>11.2</td> <td>9.0</td> <td>3</td> <td>13.50*</td> <td>103592</td> </tr> <tr> <td>20</td> <td>1.666</td> <td>W20</td> <td>112</td> <td>37.0</td> <td></td> <td>14.0</td> <td>11.2</td> <td>4</td> <td>17.80*</td> <td>103593</td> </tr> <tr> <td>25</td> <td>1.693</td> <td>W25</td> <td>120</td> <td>30.0</td> <td></td> <td>18.0</td> <td>14.0</td> <td>4</td> <td>22.70*</td> <td>103594</td> </tr> </tbody> </table>										$\varnothing d_1$	P	l_1	l_2	l_3	d_2	a			ID	ID	SV	mm	mm	mm	mm	mm	mm					10	0.833	W10	80	24.0	39	10.0	8.0	3	8.80*	130429	12	1.250	W12	89	24.0		9.0	7.1	3	10.50*	103591	15	1.250	W15	90	23.0		11.2	9.0	3	13.50*	103592	20	1.666	W20	112	37.0		14.0	11.2	4	17.80*	103593	25	1.693	W25	120	30.0		18.0	14.0	4	22.70*	103594
$\varnothing d_1$	P	l_1	l_2	l_3	d_2	a			ID	ID																																																																												
SV	mm	mm	mm	mm	mm	mm																																																																																
10	0.833	W10	80	24.0	39	10.0	8.0	3	8.80*	130429																																																																												
12	1.250	W12	89	24.0		9.0	7.1	3	10.50*	103591																																																																												
15	1.250	W15	90	23.0		11.2	9.0	3	13.50*	103592																																																																												
20	1.666	W20	112	37.0		14.0	11.2	4	17.80*	103593																																																																												
25	1.693	W25	120	30.0		18.0	14.0	4	22.70*	103594																																																																												
<p>*Tol. $\begin{matrix} +0.1 \text{ mm} \\ 0 \end{matrix}$</p>																																																																																						
<table border="1"> <thead> <tr> <th>$\varnothing d_1$</th> <th>P</th> <th>d_2</th> <th>l_1</th> <th></th> <th></th> <th>ID</th> </tr> <tr> <th>W</th> <th>mm</th> <th>mm</th> <th>mm</th> <th></th> <th></th> <th></th> </tr> </thead> <tbody> <tr> <td>6.82</td> <td>0.625</td> <td>B6</td> <td>25.0</td> <td>9.0</td> <td>4</td> <td>6.77</td> </tr> </tbody> </table>										$\varnothing d_1$	P	d_2	l_1			ID	W	mm	mm	mm				6.82	0.625	B6	25.0	9.0	4	6.77																																																								
$\varnothing d_1$	P	d_2	l_1			ID																																																																																
W	mm	mm	mm																																																																																			
6.82	0.625	B6	25.0	9.0	4	6.77																																																																																

W, SV

NPT, NPTF

Maschinengewindebohrer, NPT ANSI B1.20.1 und NPTF B1.20.3
 Directory - Machine taps, NPT ANSI B1.20.1 and NPTF B1.20.3

	N						
Merkmale Characteristics		 	 				
							
Lochart Hole type							
							
	N410-3	N410V-3	N411V-3	D5800			
NPT DIN lang NPT DIN long	DC	170	170	170	171		
NPTF DIN lang NPTF DIN long	DC	170			171		

PG, TR

Maschinen- und Handgewindebohrer, PG DIN 40430, TR ISO 2901-2904, DIN 103
 Directory - Machine and hand taps, PG DIN 40430, TR ISO 2901-2904, DIN 103

		N						
Merkmale Characteristics								
Lochart Hole type								
		N420-3	N410-1	N410-2	N410-3	N410-S	N410-8	
PG DIN lang PG DIN long	DIN 40433	172						
TR DIN lang TR DIN long	DC		173	173	173	173	172	
Toleranz Tolerance	TR 7H				173	173	172	

NPT, NPTF
PG, TR

NPT, NPTF



ANSI B1.20.1, ANSI B1.20.3

HSSE

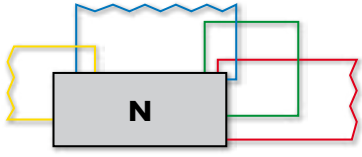

							N410-3	N410V-3	N411V-3	N410-3
N410-3										
N410V-3										
N411V-3										
N410-3										
\varnothing d ₁	P	l ₁	l ₂	d ₂	a		ID	ID	ID	ID
NPT, NPTF	TPI	mm	mm	mm	mm					
1/16	27	71	13.0	7.0	5.5	3	101961	102021	102031	101971
1/8	27	71	13.0	8.0	6.2	5	101964	102024	102034	101974
1/4	18	80	20.0	11.0	9.0	5	101963	102023	102033	101973
3/8	18	90	20.0	12.0	9.0	5	101968	102028	102038	101978
1/2	14	100	26.0	16.0	12.0	5	101962	102022	102032	101972
3/4	14	110	26.0	20.0	16.0	5	101967	102027	102037	101977
1	11.5	125	32.0	25.0	20.0	5	101965	102025	102035	101975
1 1/4	11.5	125	32.0	32.0	24.0	5	101960	102020		
1 1/2	11.5	140	32.0	36.0	29.0	5	101959	102019		
2	11.5	160	32.0	36.0	29.0	7	101966	102026		

Vc (m/min) Ø d1							
NPT, NPTF 1/16" - 1/4"		3/8" - 1/2"	3/4" - 1"	1.1/4" - 2"			
				6	5	4	3
				5	4	3	2
				10	8	7	5
				18	15	13	10

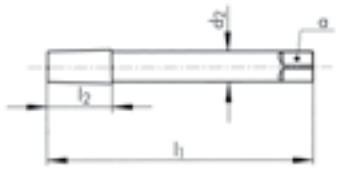
					D5800			
D5800 								
								
\varnothing'' NPT, NPTF	l_1 mm	l_2 mm	d_2 mm	a mm	ID			
1/16	70	17.0	6.0	4.9	118701			
1/8	70	17.0	8.0	6.2	110531			
1/4	80	27.0	10.0	8.0	110530			
3/8	85	27.0	12.0	9.0	110535			
1/2	95	35.0	16.0	12.0	110529			
3/4	105	35.0	20.0	16.0	110534			
1	130	43.0	25.0	20.0	110532			

Kernloch-Durchmesser für NPT- und NPTF-Gewinde Core hole diameters for NPT and NPTF threads

Bohrung zylindrisch
Vermeiden, da schnellere Abnützung des Gewindebohrers und Klemmen

Parallel hole
Increased tap wear, not recommended

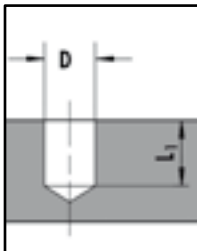

Bohrung konisch 1:16
Zylindrisch bohren nach $\varnothing D_2$ und konisch aufreiben auf $\varnothing D_3$

Tapered hole 1:16
Pre-drill at $\varnothing D_2$ and taper-ream to $\varnothing D_3$

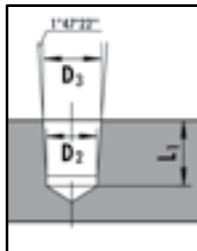

Gewindeschneiden
Gewindebohrer auf Nennmass L_3 eindrehen

Tapped hole
Engage tap to hole depth $L_3 = \text{nominal } \varnothing$

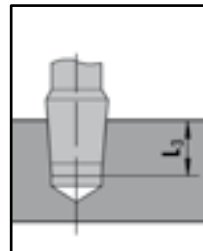

*Es wird empfohlen, das Kernloch auf D_3 maxi konisch aufzureiben.

*Taper-ream at upper limit D_3 is recommended

\varnothing'' NPT, NPTF	D mm	L_1 mm	D_2 mm	NPT $D_3(+0.05)$ mm	NPTF $D_3(+0.05)$ mm	L_3 mm
1/16	6.15	12.00	6.00	6.39	6.41	10.20
1/8	8.50	12.00	8.30	8.74	8.76	10.30
1/4	11.00	17.50	10.80	11.36	11.40	15.10
3/8	14.50	17.50	14.20	14.80	14.84	15.30
1/2	17.90	23.00	17.50	18.32	18.33	20.00
3/4	23.20	23.00	22.80	23.67	23.68	20.50
1	29.00	28.00	28.60	29.69	29.72	24.60

PG DIN 40430 TR ISO 2901-2904, DIN 103

HSSE

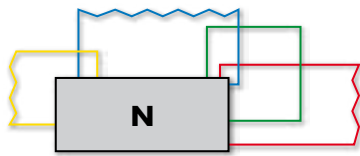
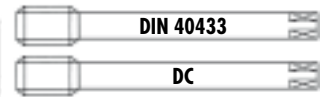

N420-3

N410-8

N420-3





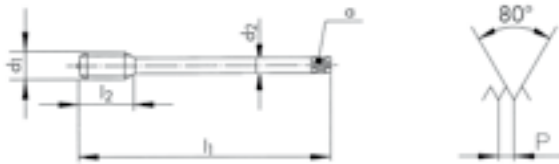

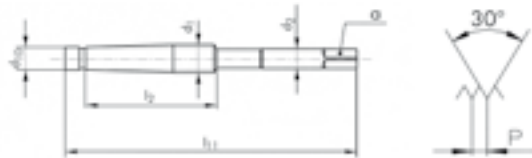

N410-8



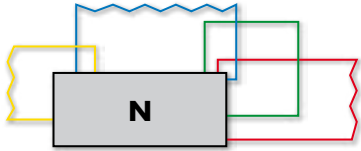

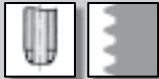

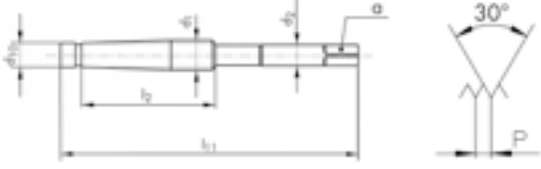



















$\varnothing d_1$ PG	P TPI	d_1 mm	l_1 mm	l_2 mm	d_2 mm	a mm			ID
7	20	12.50	100	24.0	9.0	7.0	3	11.30	104901
9	18	15.20	100	26.0	12.0	9.0	3	13.90	104902
11	18	18.60	110	26.0	14.0	11.0	4	17.30	104903
13.5	18	20.40	125	28.0	16.0	12.0	4	19.10	104904
16	18	22.50	125	28.0	18.0	14.5	4	21.20	104905
21	16	28.30	150	36.0	22.0	18.0	4	26.80	104906
29	16	37.00	170	38.0	28.0	22.0	4	35.50	104907
36	16	47.00	190	38.0	36.0	29.0	5	45.50	104908

















$\varnothing d_1$ TR	P mm	l_{11} mm	l_2 mm	d_{10} mm	d_2 mm	a mm			ID
10	2.00	100	45.0	8.20	7.0	5.5	3	8.20	102008
12	3.00	140	75.0	9.25	8.0	6.2	3	9.25	102009
14	3.00	150	75.0	11.25	10.0	8.0	3	11.25	102010
16	4.00	180	100.0	12.25	11.0	9.0	3	12.25	102011
18	4.00	180	100.0	14.25	12.0	9.0	3	14.25	102012
20	4.00	190	100.0	16.25	14.0	11.0	3	16.25	102013
22	5.00	220	110.0	17.25	16.0	12.0	4	17.25	111616
24	5.00	220	110.0	19.25	18.0	14.5	4	19.25	102015

									N410-1	N410-2	N410-3	N410-S
												
N410-1												
N410-2												
N410-3												
N410-S												
												
									7H		7H	
∅ d ₁ TR	P mm	l ₁₁ mm	l ₂ mm	d ₁₀ mm	d ₂ mm	a mm			ID	ID	ID	ID
10	2.00	85	30.0	8.20	7.0	5.5	3	8.20	* 101827	* 101838	* 101979	* 110972
12	3.00	115	45.0	9.25	8.0	6.2	3	9.25	* 101828	* 101839	* 101980	* 110973
16	4.00	165	65.0	12.25	11.0	9.0	3	12.25	* 101830	* 101841	* 101982	* 110975
20	4.00	175	65.0	16.25	14.0	11.0	3	16.25	* 101832	* 101843	* 101984	* 110977

		N				Z	S	
Merkmale Characteristics			 V	 R40	 R40 V	 R45 VS	 R35 VS	 R35 VS
								
Lochart Hole type								
	N320-4	N320V-4	N360-3	N360V-3	Z370VS-3	S320VS-4	S360VS-3	
DIN lang DIN long	~DIN 40435	176	176	177	177			
DIN lang DIN long	~DIN 2184-1	180/183		180/183		181/184	184	184
Gewinde Thread	EG M	176	176	177	177			
Gewinde Thread	EG UNC	180		180		181		
Gewinde Thread	EG UNF	183		183		184	184	184
	N420-4	N420V-4	N460-3	N460V-3				
DIN lang DIN long	~DIN 40435	176	176	177	177			
DIN lang DIN long	~DIN 2184-1	180/183		180/183				
Gewinde Thread	EG M	176	176	177	177			
Gewinde Thread	EG UNC	180		180				
Gewinde Thread	EG UNF	183		183				

EG

Maschinengewindebohrer, Aufnahmegewinde für Gewindeeinsätze EG M, EG UNC, EG UNF
 Directory - Machine taps for wire screw thread inserts, EG M, EG UNC, EG UNF

SA			TL	
			 VS	 VS
				
				
SA320-4	SA350-3	SA390-3	TL320VS-4	TL351VS-3
178	178	179	178	178
182/185	182/185	184	182/185	182/185
178	178	179	178	178
182	182		182	182
185	185	184	185	185

**THREADING
TECHNOLOGY**

DC[®]

www.dcswiss.com

EG M, EG UN



≤ Ø 2.8 > Ø 2.8

PM

HSSE

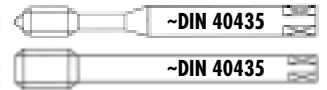

										N320-4	N320V-4	N420-4	N420V-4
N320-4													
N320V-4	V												
N420-4													
N420V-4	V												
Ø d ₁ EG M	P mm	d ₁ mm	l ₁ mm	l ₂ mm	l ₃ mm	d ₂ mm	a mm			ID	ID	ID	ID
2	0.40	2.520	50	10.0		2.8	2.1	3	2.10	101537	118788		
2.5	0.45	3.084	56	12.0	18	3.5	2.7	3	2.65	101538			
3	0.50	3.650	56	13.0	20	4.0	3.0	3	3.15	101539	142804		
4	0.70	4.910	70	15.0	25	6.0	4.9	3	4.20	101540	142805		
5	0.80	6.040	80	17.0	30	6.0	4.9	3	5.25	101541	142806		
6	1.00	7.300	80	17.0	30	7.0	5.5	3	6.30	101542	142807		
8	1.25	9.624	100	22.0	39	10.0	8.0	3	8.40	101543	142808		
10	1.50	11.948	100	24.0		9.0	7.0	3	10.40			102252	142809
12	1.75	14.274	110	28.0		11.0	9.0	3	12.50			102253	142810
14	2.00	16.598	110	30.0		12.0	9.0	3	14.60				* 142811
16	2.00	18.598	125	33.0		14.0	11.0	3	16.60			102255	142812



≤ Ø 2.8 > Ø 2.8

PM **HSSE**

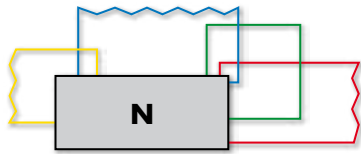
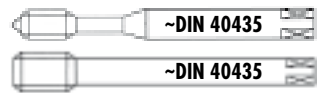

N360-3



N360V-3



N460-3



N460V-3



N360-3

N360V-3

N460-3

N460V-3

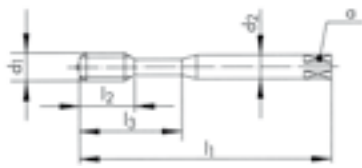

6H mod

6H mod

6H mod

6H mod

Ø d ₁ EG M	P mm	d ₁ mm	l ₁ mm	l ₂ mm	l ₃ mm	d ₂ mm	a mm		
2	0.40	2.520	50	9.0		2.8	2.1	2	2.10
2.5	0.45	3.084	56	5.5	18	3.5	2.7	3	2.65
3	0.50	3.650	56	6.5	20	4.0	3.0	3	3.15
4	0.70	4.910	70	9.0	25	6.0	4.9	3	4.20
5	0.80	6.040	80	11.0	30	6.0	4.9	3	5.25
6	1.00	7.300	80	11.0	30	7.0	5.5	3	6.30
8	1.25	9.624	100	14.0	39	10.0	8.0	3	8.40
10	1.50	11.948	100	14.0		9.0	7.0	3	10.40
12	1.75	14.274	110	14.0		11.0	9.0	3	12.50
14	2.00	16.598	110	18.0		12.0	9.0	3	14.60
16	2.00	18.598	125	21.0		14.0	11.0	3	16.60

ID

ID

ID

ID

101599

101600

101601

142813

101602

142814

101603

142815

101604

142816

101605

142817

102335

142818

102336

142819

102337

142820

102338

142821



aero

										SA320-4	SA350-3	TL320VS-4	TL351VS-3
<div style="display: flex; justify-content: space-between;"> <div style="width: 45%;"> <p>SA320-4 52 53</p> <p>SA350-3 52 53</p> <p>TL320VS-4 VS 41 42</p> <p>TL351VS-3 VS 41 42</p> </div> <div style="width: 50%; text-align: center;"> </div> </div>													
										B 4 x P	C 2.5 x P	B 4 x P	C 2.5 x P
										6H mod	6H mod	6H mod	6H mod
$\varnothing d_1$ EG M	P mm	d_2 mm	l_1 mm	l_2 mm	l_3 mm	d_2 mm	α mm			ID	ID	ID	ID
3	0.50	3.650	56	13.0		4.0	3.0	3	3.15	147676	147682	* 152001	150478
4	0.70	4.910	70	15.0		6.0	4.9	3	4.20	147678	147684	* 152002	152003
5	0.80	6.040	80	15.0	23	6.0	4.9	3	5.25	147680	147686		150184
6	1.00	7.300	80	15.0	23	7.0	5.5	3	6.30	147688	147692	* 152004	152005
8	1.25	9.624	100	20.0	33	10.0	8.0	3	8.40	149354	149356	* 152088	152089



aero

SA390-3

SA390-3

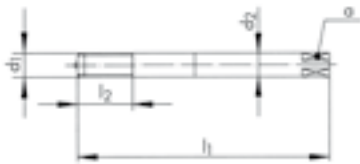

$\varnothing d_1$ EG M	P mm	d_1 mm	l_1 mm	l_2 mm	d_2 mm	α mm		
3	0.50	3.650	56	13.0	4.0	3.0	3	3.15
4	0.70	4.910	70	15.0	6.0	4.9	3	4.20
5	0.80	6.040	80	20.0	6.0	4.9	3	5.25
6	1.00	7.300	80	20.0	7.0	5.5	3	6.30
8	1.25	9.624	100	30.0	10.0	8.0	3	8.40
10	1.50	11.948	110	35.0	12.0	9.0	3	10.40

ID

149669
149688
149710
149723
149748
149767

EG UNC

NASM33537



HSSE

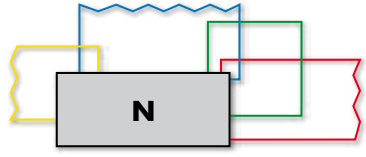
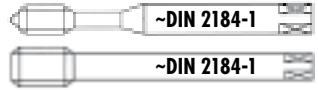

										N320-4	N420-4	N360-3	N460-3
N320-4													
N420-4													
N360-3													
N460-3													
										3B	3B	3B	3B
Ø" d₁ EG UNC	P TPI	d₁ mm	l₁ mm	l₂ mm	l₃ mm	d₂ mm	a mm			ID	ID		
4	40	3.67	56	13.0	20	4.0	3.0	3	3.05	110946			
6	32	4.53	70	15.0	25	6.0	4.9	3	3.75	110948			
8	32	5.19	70	15.0	25	6.0	4.9	3	4.45	110949			
10	24	6.20	80	17.0	30	7.0	5.5	3	5.10	* 110945			
1/4	20	8.00	90	20.0	35	8.0	6.2	3	6.70	110944			
5/16	18	9.77	100	22.0	39	10.0	8.0	3	8.40	110947			
3/8	16	11.59	110	24.0		9.0	7.0	3	10.00		110033		
1/2	13	15.23	110	30.0		12.0	9.0	3	13.30		104935		
Ø" d₁ EG UNC	P TPI	d₁ mm	l₁ mm	l₂ mm	l₃ mm	d₂ mm	a mm				ID	ID	
4	40	3.67	56	6.5	20	4.0	3.0	3	3.05		110018		
6	32	4.53	70	9.0	25	6.0	4.9	3	3.75		110019		
8	32	5.19	70	9.0	25	6.0	4.9	3	4.45		110956		
10	24	6.20	80	11.0	30	7.0	5.5	3	5.10		110954		
1/4	20	8.00	90	12.5	35	8.0	6.2	3	6.70		110024		
5/16	18	9.77	100	14.0	39	10.0	8.0	3	8.40		111759		
3/8	16	11.58	110	14.0		9.0	7.0	3	10.00			111715	
1/2	13	15.23	110	18.0		12.0	9.0	3	13.30			111558	

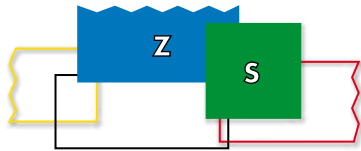

Z370VS-3

Z370VS-3

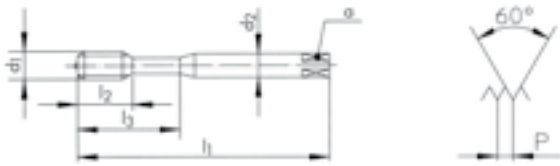
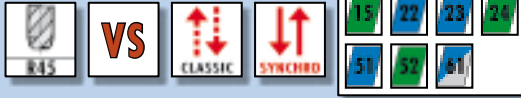

\varnothing d ₁ EG UNC	P TPI	d ₁ mm	l ₁ mm	l ₂ mm	l ₃ mm	d ₂ h6 mm	α mm			ID
4	40	3.67	56	6.5	20	4.0 (h9)	3.0	3	3.05	165126
6	32	4.53	70	9.0	25	6.0	4.9	3	3.75	165127
8	32	5.19	70	9.0	25	6.0	4.9	3	4.45	165128



aero

										SA320-4	SA350-3	TL320VS-4	TL351VS-3
\varnothing d ₁ EG UNC	P TPI	d ₁ mm	l ₁ mm	l ₂ mm	l ₃ mm	d ₂ mm	a mm			ID	ID	ID	ID
4	40	3.67	56	13.0		4.0	3.0	3	3.05	149073	149075	* 152030	152031
6	32	4.53	70	15.0		6.0	4.9	3	3.75	149121	149123	* 152040	152041
8	32	5.19	70	15.0		6.0	4.9	3	4.45	149170	149172	* 152052	152053
1/4	20	8.00	90	18.0	29	8.0	6.2	3	6.70	149284	149286	* 152073	152074
5/16	18	9.77	100	20.0	33	10.0	8.0	3	8.40	* 149358	* 149360	* 152090	* 152091



HSSE

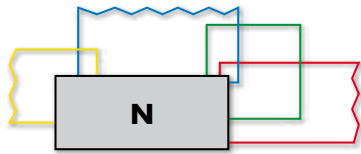
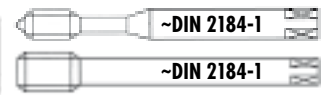

N320-4		
N420-4		
N360-3		
N460-3		

N320-4	N420-4	N360-3	N460-3
--------	--------	--------	--------



--	--	--	--

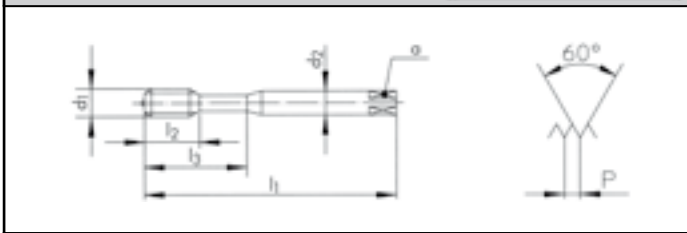

3B	3B	3B	3B

Ø" d ₁ EG UNF	P TPI	d ₁ mm	l ₁ mm	l ₂ mm	l ₃ mm	d ₂ mm	a mm		
6	40	4.33	63	14.0	21	4.5	3.4	3	3.70
8	36	5.08	70	15.0	25	6.0	4.9	3	4.40
10	32	5.85	80	17.0	30	6.0	4.9	3	5.10
1/4	28	7.52	90	20.0	35	8.0	6.2	3	6.65
5/16	24	9.31	90	20.0	35	9.0	7.0	3	8.20
3/8	24	10.89	100	19.0		8.0	6.2	3	9.80
1/2	20	14.35	100	24.0		11.0	9.0	3	13.10

ID	ID
118879	
118882	
104941	
110234	
118876	
	118873
	118865

Ø" d ₁ EG UNF	P TPI	d ₁ mm	l ₁ mm	l ₂ mm	l ₃ mm	d ₂ mm	a mm		
6	40	4.33	63	7.5	21	4.5	3.4	3	3.70
8	36	5.08	70	9.0	25	6.0	4.9	3	4.40
10	32	5.85	80	11.0	30	6.0	4.9	3	5.10
1/4	28	7.52	90	12.5	35	8.0	6.2	3	6.65
5/16	24	9.31	90	12.5	35	9.0	7.0	3	8.20
3/8	24	10.89	100	19.0		8.0	6.2	3	9.80
1/2	20	14.35	100	14.0		11.0	9.0	3	13.10

ID	ID
	110959
	110960
	104946
	110020
	111619
	110027
	104951

EG UNC
EG UNF

EG UNF NASM33537



PM

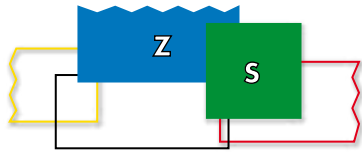
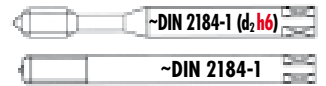

Z370VS-3 S320VS-4 S360VS-3 SA390-3



Z370VS-3

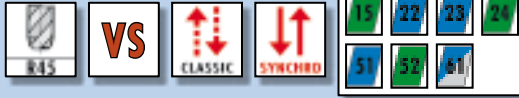

S320VS-4

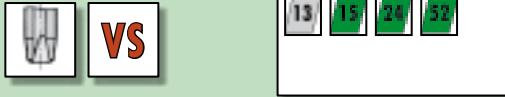

S360VS-3



SA390-3

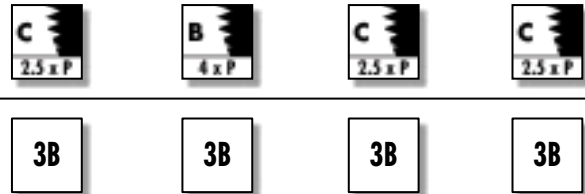
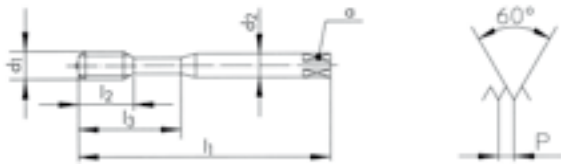
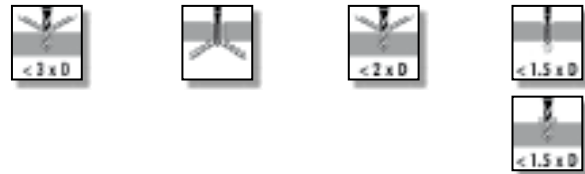

Ø" d ₁ EG UNF	P TPI	d ₁ mm	l ₁ mm	l ₂ mm	l ₃ mm	d ₂ h6 mm	a mm		
10	32	5.85	80	11.0	30	6.0	4.9	3	5.10
1/4	28	7.52	90	12.5	35	8.0	6.2	3	6.65
5/16	24	9.31	90	12.5	35	*8.0	*6.2	3	8.20

ID
165129
165130
165131

* Norme DC / * DC Norm / * Norma DC

Ø" d ₁ EG UNF	P TPI	d ₁ mm	l ₁ mm	l ₂ mm	l ₃ mm	d ₂ mm	a mm		
10	32	5.85	80	17.0	30	6.0	4.9	3	5.10
1/4	28	7.52	90	20.0	35	8.0	6.2	3	6.65
5/16	24	9.31	90	20.0	35	9.0	7.0	3	8.20

ID
111821
111822
111823

Ø" d ₁ EG UNF	P TPI	d ₁ mm	l ₁ mm	l ₂ mm	l ₃ mm	d ₂ mm	a mm		
10	32	5.85	80	11.0	30	6.0	4.9	3	5.10
1/4	28	7.52	90	12.5	35	8.0	6.2	3	6.65
5/16	24	9.31	90	12.5	35	9.0	7.0	3	8.20

ID
111811
111812
111824

Ø" d ₁ EG UNF	P TPI	d ₁ mm	l ₁ mm	l ₂ mm	d ₂ mm	a mm		
10	32	5.85	80	20.0	6.0	4.9	3	5.10
1/4	28	7.52	90	25.0	8.0	6.2	3	6.65

ID
149702
149724



PM



aero

SA320-4

SA350-3

TL320VS-4

TL351VS-3



SA320-4



SA350-3



TL320VS-4



VS



TL351VS-3



VS

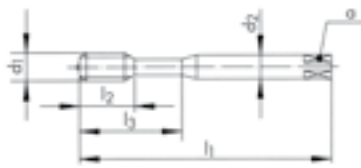

Ø" d ₁ EG UNF	P TPI	d ₁ mm	l ₁ mm	l ₂ mm	l ₃ mm	d ₂ mm	a mm		
10	32	5.85	80	15.0	23	6.0	4.9	3	5.10
1/4	28	7.52	90	18.0	29	8.0	6.2	3	6.65
5/16	24	9.31	90	20.0	31	9.0	7.0	3	8.20

ID

ID

ID

ID

149190

149192

* 148009

148008

146099

149268

* 148015

148014

149336

149338

148021

KRONENGEWINDEBOHRER

CROWN TAPS

Allgemeines

Der DC-Kronengewindebohrer mit "V"-Oberflächenbehandlung ist ein Hochleistungswerkzeug, das eine sichere Toleranzhaltigkeit und eine sehr saubere Oberflächenqualität garantiert.

Anwendungsbereich

Dank der stirnseitigen Aussparung, die die Spanaufnahme erlaubt, kann der Kronengewindebohrer sowohl für das Schneiden von Durchgangs- als auch von Sacklöchern verwendet werden. Er ist bestimmt für die Bearbeitung von Werkstoffen mit einer Zugfestigkeit von bis zu 850 N/mm² und einer Bruchdehnung von maximal 30 %.

Einsatz

Der DC-Kronengewindebohrer kann für Durchgangslöcher jeglicher Gewindetiefe eingesetzt werden. Für einwandfreie Sacklochgewinde muss jedoch die Tiefe der Kernlochbohrung jeweils entsprechend angepasst und die nachstehenden Hinweise befolgt werden:

- Gewinde schneiden, bis Rutschkupplung anspricht
- Gewindebohrer zurückdrehen und Späne entfernen
- Gewinde fertig schneiden.

Spezielle Anforderungen

Das einwandfreie Funktionieren der DC-Kronengewindebohrer und der damit erzielten Gewindequalität sind abhängig von folgenden Voraussetzungen:

- Zentrierfehler darf 0.1 mm nicht überschreiten
- Einsatz eines entsprechenden Gewindeschneidfutters, das einen einwandfreien Rundlauf ermöglicht
- Korrekte Schnittgeschwindigkeit wählen
- Schneidöl dem Werkstoff anpassen
- Einspannen in einem Gewindeschneidfutter mit Längenausgleich und Überlastungskupplung
- Überlastungskupplung so einstellen, dass das Ansprechdrehmoment nur leicht höher liegt als das Schneiddrehmoment.

Es ist empfehlenswert, beim ersten Gewinde die Rutschkupplung bis zum Gleiten zu entlasten und dann schrittweise anzuziehen, bis der Gewindebohrer mitgenommen wird.

Spanaufnahme

Die Spanaufnahmekapazität der stirnseitigen Krone ist ausreichend für:

Gewindedurchmesser	Ø 20 - 29 mm	≥ Ø 30 mm
M	-	1.4 x D
MF	1.2 x D	1.4 x D
UN-8	-	1.4 x D
G	1.2 x D	1.4 x D

General information

The DC crown tap with "V" surface treatment to prevent cold welding is a tool of high performance, which offers a very high quality surface finish of the tapped threads.

Application rang

Thanks to the front recess providing space for the chip collection, the DC crown tap is suitable for both, through and blind hole tapping. The crown tap can be used for materials with a tensile strength up to 850 N/mm² and an elongation of maximum 30 %.

Utilization

The crown tap can be used for through holes of any depth. However, for an optimal blind hole threading, the core hole depth must be adapted accordingly and the following application instructions must be followed:

- Tap until tapping head clutch slips
- Retract tap and clear chips
- Tap to the full depth.

General hints

The efficient operation of DC crown taps, as well as the quality of the cut threads, depend on observation of the following rules:

- Do not exceed the maximum permissible centering error of 0.1 mm
- The tap must run concentrically, use a suitable tapping head
- Tap at the correct cutting speed
- Select a coolant to suit the material being tapped
- Use a tapping head with axial compensation and safety clutch
- Set the safety clutch so that it will slip at just above the tapping torque.

When tapping the first hole, slacken the clutch until it slips, then gradually tighten it until the tap is driven.

Chip accumulation

The chip accumulation capacity of the recess is the following :

Thread diameter	Ø 20 - 29 mm	≥ Ø 30 mm
M	-	1.4 x D
MF	1.2 x D	1.4 x D
UN-8	-	1.4 x D
G	1.2 x D	1.4 x D

Schnittgeschwindigkeiten und Drehzahlen (Richtwerte) - Cutting and spindle speeds (guide values)

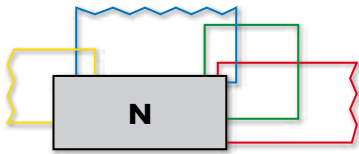

M				MF				MF				UN-8			
P	V _c (m/min)	n (U/min)		P	V _c (m/min)	n (U/min)		P	V _c (m/min)	n (U/min)		P TPI	V _c (m/min)	n (U/min)	
30	3.5	7.9	84	22	1.5	8.0	116	45	1.5	6.9	49	1 1/4"	8.0	7.8	77
33	3.5	7.7	74	24	1.5	8.0	106	45	2.0	6.9	49	1 3/8"	8.0	7.6	69
36	4.0	7.5	66	26	1.5	7.9	97	48	1.5	6.6	44	1 1/2"	8.0	7.3	62
39	4.0	7.3	60	28	1.5	7.9	90	48	2.0	6.6	44	1 5/8"	8.0	7.1	55
42	4.5	7.1	54	30	1.5	7.9	84	48	3.0	6.6	44	1 3/4"	8.0	6.9	49
45	4.5	6.9	49	30	2.0	7.9	84	48	4.0	6.6	44	1 7/8"	8.0	6.7	45
48	5.0	6.6	44	32	1.5	7.8	77	50	1.5	6.5	41	2"	8.0	6.4	40
52	5.0	6.4	39	32	2.0	7.8	77	52	1.5	6.4	39				
56	5.5	6.1	35	33	1.5	7.7	74	52	3.0	6.4	39				
60	5.5	5.8	31	33	2.0	7.7	74	55	1.5	6.2	36				
64	6.0	5.5	28	34	1.5	7.6	71	56	4.0	6.1	35				
68	6.0	5.2	25	35	1.5	7.6	69	60	2.0	5.8	31				
				36	1.5	7.5	66	64	4.0	5.5	28				
				36	2.0	7.5	66	68	4.0	5.2	25				
				36	3.0	7.5	66	72	6.0	5.0	22				
				38	1.5	7.3	62	76	6.0	4.7	20				
				40	1.5	7.2	57	80	2.0	4.4	18				
				40	2.0	7.2	57	80	4.0	4.4	18				
				42	1.5	7.1	54	80	6.0	4.4	18				
				42	2.0	7.1	54	90	6.0	3.7	13				
				42	3.0	7.1	54	100	6.0	3.0	10				
				42	4.0	7.1	54	110	6.0	2.5	7				

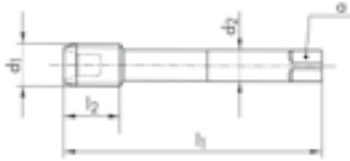

N470V-4

N470V-4



$\varnothing d_1$ M	P mm	l_1 mm	l_2 mm	d_2 mm	a mm		
30	3.50	180	39.0	22.0	18.0	5	26.50
33	3.50	180	39.0	22.0	18.0	5	29.50
36	4.00	200	43.0	25.0	20.0	5	32.00
39	4.00	200	43.0	25.0	20.0	5	35.00
42	4.50	220	47.0	28.0	22.0	5	37.50
45	4.50	220	47.0	28.0	22.0	5	40.50
48	5.00	240	52.0	32.0	24.0	5	43.00
52	5.00	240	52.0	32.0	24.0	5	47.00
56	5.50	260	58.0	36.0	29.0	6	50.50
60	5.50	260	58.0	36.0	29.0	6	54.50
64	6.00	290	64.0	40.0	32.0	6	58.00
68	6.00	290	64.0	40.0	32.0	6	62.00

ID

102575

* 102576

102577

102578

102579

102580

102581

102582

102583

102584

102585

* 102586



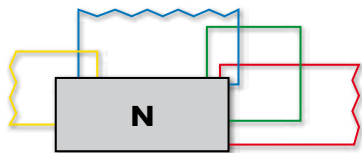

N470V-3

N470V-3

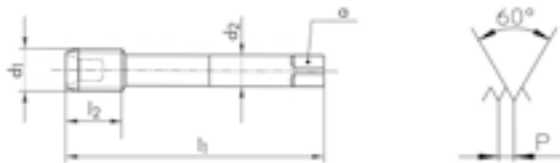
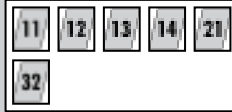

$\varnothing d_1$ MF	P mm	l_1 mm	l_2 mm	d_2 mm	a mm			ID
Δ22	1.50	125	28.0	18.0	14.5	4	20.50	* 102526
Δ26	1.50	140	30.0	18.0	14.5	4	24.50	* 102529
Δ28	1.50	140	30.0	20.0	16.0	4	26.50	* 102530
30	1.50	160	32.0	22.0	18.0	5	28.50	* 102531
32	1.50	160	32.0	22.0	18.0	5	30.50	* 102533
34	1.50	160	26.0	22.0	18.0	5	32.50	* 102537
35	1.50	175	28.0	25.0	20.0	5	33.50	* 102538
36	2.00	175	35.0	25.0	20.0	5	34.00	102540
36	3.00	200	43.0	25.0	20.0	5	33.00	102541
38	1.50	175	28.0	25.0	20.0	5	36.50	* 102542
40	1.50	190	31.0	28.0	22.0	5	38.50	* 102543
40	2.00	190	38.0	28.0	22.0	5	38.00	* 102544
42	2.00	190	38.0	28.0	22.0	5	40.00	102546
42	3.00	220	47.0	28.0	22.0	5	39.00	102547
48	1.50	205	34.0	32.0	24.0	5	46.50	* 102551
48	3.00	205	41.0	32.0	24.0	5	45.00	102553
52	3.00	205	41.0	32.0	24.0	5	49.00	102557
56	4.00	260	58.0	36.0	29.0	6	52.00	102559
64	4.00	290	64.0	40.0	32.0	6	60.00	102561
80	4.00	270	56.0	45.0	35.0	7	76.00	* 102564



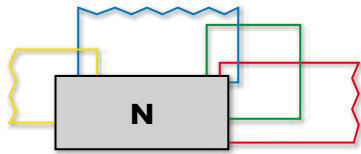



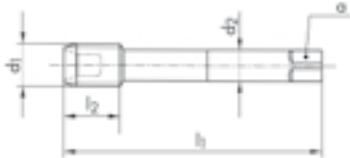

N470V-3

N470V-3

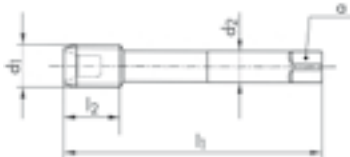

Ø" d ₁ UN	P TPI	d ₁ mm	l ₁ mm	l ₂ mm	d ₂ mm	a mm			ID
1 1/4	8	31.75	180	39.0	22.0	18.0	5	28.70	102566
1 3/8	8	34.92	180	39.0	22.0	18.0	5	31.80	102568
1 1/2	8	38.10	200	43.0	25.0	20.0	5	35.00	102565
1 5/8	8	41.27	220	47.0	28.0	22.0	5	38.20	102569
1 3/4	8	44.45	220	47.0	28.0	22.0	5	41.40	102567
1 7/8	8	47.62	240	52.0	32.0	24.0	5	44.50	102570
2	8	50.80	205	41.0	32.0	24.0	5	47.70	102572
2 1/4	8	57.15	220	45.0	36.0	29.0	6	54.10	102571
2 1/2	8	63.50	220	45.0	36.0	29.0	6	60.40	111879



Ø" d ₁ G	P TPI	d ₁ mm	l ₁ mm	l ₂ mm	d ₂ mm	a mm			ID
^Δ 1/2	14	20.95	140	32.0	16.0	12.0	4	18.90	* 102521
^Δ 3/4	14	26.44	150	34.0	20.0	16.0	4	24.40	102525
1	11	33.24	160	32.0	22.0	18.0	5	30.70	102522
1 1/4	11	41.91	190	38.0	28.0	22.0	5	39.30	102519
1 1/2	11	47.80	205	41.0	32.0	24.0	5	45.20	102518
1 3/4	11	53.74	205	41.0	32.0	24.0	5	51.20	* 102520
2	11	59.61	220	45.0	36.0	29.0	6	57.00	102524



KOMBI-GEWINDEBOHRER

Allgemeines

Der DC-Kombi-Gewindebohrer ist ein Werkzeug, das das Schneiden des Kernloches und des Gewindes in einem Arbeitsgang erlaubt, ohne dass ein Werkzeugwechsel notwendig ist.

Er ist ideal für den Einsatz auf CNC-Maschinen, Bohrtasteinheiten, Drehbänken mit Revolverkopf und Gewindeschneidmaschinen.

Anwendungsbereich

Werkstoffe mit einer Zugfestigkeit bis 750 N/mm² lassen sich mit dem DC-Kombi-Gewindebohrer bearbeiten, also gewisse Stähle, Grauguss, Messing, Aluminium.

Spezielle Anforderungen

- Das Kernloch muss vollständig durchbohrt sein, bevor der Gewindebohrer zu schneiden beginnt.
- Bei der Bearbeitung von kurzspanenden Werkstoffen darf die Gewindetiefe 1.8 x D nicht überschreiten (Typ N5952 bis 2 x D).
- Bei der Bearbeitung von langspanenden Werkstoffen darf die Gewindetiefe 1.2 x D nicht überschreiten.
- Schmieren wie beim Gewindeschneiden.

Schnittgeschwindigkeiten

Wenn die Maschine, auf der die Kombiboherer eingesetzt werden, es erlaubt, ist es vorteilhaft, die idealste Drehzahl für das Gewindeschneiden zu wählen. (Siehe dazu unsere Anwendungstabelle auf Seite 7).

Für Maschinen, auf denen eine unterschiedliche Drehzahl für das Bohren und Gewindeschneiden nicht eingestellt werden kann, empfehlen wir die nachstehend aufgeführten Schnittwerte.

Programmierungs-Instruktionen

Ansenkung:

Gleichzeitig zentrieren und ansenken.

Programmschritte bei Spindelvorschub und Rotation, 100 % synchronisiert (Idealfall):

- 1) Kombi-Gewindebohrer im Eilgang in Arbeitsposition bringen
- 2) Bohren:
 - Drehzahl einstellen
 - Vorschub einstellen
 - lange Späne vermeiden
 - Späne entfernen
- 3) Gewindeanschnitt in Startposition bringen
- 4) Gewindeschneiden:
 - Drehzahl einstellen
 - Vorschub (100 %) einstellen
 - Gewindetiefe einstellen
 - Gewindebohrer muss vor Arbeitsbeginn spanfrei sein
- 5) Kombi-Gewindebohrer zurück in Startposition.

Programmschritte bei nicht voller Synchronisation von Spindelvorschub und Rotation:

Wichtig: Kombi-Gewindebohrer in Futter spannen, mit blockierter Andrucksfeder, jedoch mit Längenausgleich.

- 1) Kombi-Gewindebohrer im Eilgang in Arbeitsposition bringen
- 2) Bohren:
 - Drehzahl einstellen
 - Vorschub einstellen
 - lange Späne vermeiden
 - Späne entfernen
- 3) Gewindeanschnitt in Startposition bringen
- 4) Gewindeschneiden:
 - Drehzahl einstellen
 - Vorschub = 90 - 95 %
 - Gewindetiefe einstellen
- 5) Kombi-Gewindebohrer zurück in Startposition.

Schnittgeschwindigkeiten und Drehzahlen (Richtwerte)

Werkstoffgruppen	Vc (m/min)	Durchmesser und Drehzahl U/min										
		M3	M4	M5	M6	M8	M10	M12	M14	M16	M18	M20
Stähle bis 500 N/mm ²	20	2120	1600	1270	1060	800	640	530	460	400	360	320
Stähle über 500 N/mm ²	15	1600	1200	950	800	600	480	400	340	300	270	240
Grauguss weich	20	2120	1600	1270	1060	800	640	530	460	400	360	320
Grauguss hart	15	1600	1200	950	800	600	480	400	340	300	270	240
Messing	25	2650	2000	1600	1330	950	800	660	570	500	450	400
Aluminium	25	2650	2000	1600	1330	950	800	660	570	500	450	400

COMBINATION DRILL/TAPS

General information

DC combination drill/taps - two tools in one, which allows the drilling and the threading of a workpiece without changing the tool.

It is the optimal solution for CNC-machines, drilling heads, turret lathes and tapping machines.

Application rang

DC combination drill/taps are recommended for use in materials with a tensile strenght up to 750 N/mm², such as certain steels, cast iron, aluminium, brass.

General hints

- The core hole must be completely drilled through before the tap starts cutting.
- In short chipping materials, the depth of thread should not exceed 1.8 x D (type N5952 up to 2 x D).
- In long chipping materials, the depth of thread should not exceed 1.2 x D.
- Lubricate as for tapping.

Cutting speeds

On drilling heads and CNC-machines, the ideal speeds for drilling and tapping are selected (see our application chart on page 7).

If the same speed is selected for both drilling and tapping, we recommend the values indicated below.

Programming instructions

Countersinking:

Center and countersink simultaneously.

Programming steps for spindle feed and rotation 100 % synchronised (ideal case):

- 1) Combi-drill-tap in rapid to start position
- 2) Drilling:
 - set speed
 - set feed
 - avoid long chips
 - clear shavings
- 3) Tapping section in start position
- 4) Tapping:
 - set speed
 - feed = 100 % pitch
 - set thread depth
 - tap must be free of swarf before starting to cut
- 5) Combi-drill-tap returns to start position.









Programming steps for spindle feed rotation not fully synchronised:

Important: Mount combination drill-tap in chuck with locked pressure spring, but with axial compensation on pull.

- 1) Combi-drill-tap in rapid to start position
- 2) Drilling:
 - set speed
 - set feed
 - avoid long chips
 - clear shavings
- 3) Tapping section in start position
- 4) Tapping:
 - set speed
 - feed = 90 - 95 % pitch
 - set thread depth
- 5) Combi-drill-tap returns to start position.

Cutting and spindle speeds (guide values)

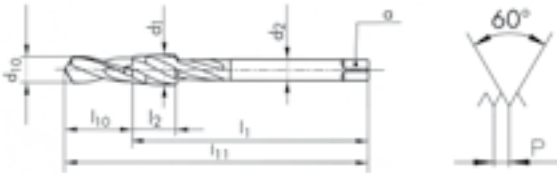
Material groups	Vc (m/min)	Speeds for different diameters										
		M3	M4	M5	M6	M8	M10	M12	M14	M16	M18	M20
Steels up to 500 N/mm ²	20	2120	1600	1270	1060	800	640	530	460	400	360	320
Steels over 500 N/mm ²	15	1600	1200	950	800	600	480	400	340	300	270	240
Cast iron, soft	20	2120	1600	1270	1060	800	640	530	460	400	360	320
Cast iron, hard	15	1600	1200	950	800	600	480	400	340	300	270	240
Brass	25	2650	2000	1600	1330	950	800	660	570	500	450	400
Aluminium	25	2650	2000	1600	1330	950	800	660	570	500	450	400

								N5951	N5952	N5951	
N5951											
N5952											
N5951											
											
								ISO 2 6H	ISO 2 6H	7H EN 60423	
∅ d ₁ M	P	l ₁₁	l ₂	d ₂	α	d ₁₀	l ₁₀	ID			
3	0.50	62.0	12.5	3.5	2.7	2.55	9.0	104578			
4	0.70	66.0	16.0	4.5	3.4	3.36	10.0	104580			
5	0.80	75.5	18.0	6.0	4.9	4.26	12.5	104583			
6	1.00	81.0	20.0	6.0	4.9	5.05	14.0	104585			
8	1.25	93.0	12.0	6.0	4.9	6.80	20.0	104588			
10	1.50	99.0	14.0	7.0	5.5	8.55	22.0	104571			
12	1.75	106.0	16.0	9.0	7.0	10.30	25.0	104573			
16	2.00	123.0	20.0	12.0	9.0	14.10	32.0	104576			
20	2.50	132.0	22.0	16.0	12.0	17.60	36.0	104577			
∅ d ₁ M	P	l ₁₁	l ₂	d ₂	α	d ₁₀	l ₁₀	ID			
4	0.70	77.0	16.0	4.5	3.4	3.36	21.0	104608			
5	0.80	87.0	18.0	6.0	4.9	4.26	24.0	104609			
6	1.00	94.0	20.0	6.0	4.9	5.05	27.0	104610			
8	1.25	109.0	12.0	6.0	4.9	6.80	36.0	104611			
10	1.50	118.0	14.0	7.0	5.5	8.55	41.0	104603			
∅ d ₁ MF	P	l ₁₁	l ₂	d ₂	α	d ₁₀	l ₁₀	ID			
4	0.50	66.0	16.0	4.5	3.4	3.55	10.0	* 104579			
5	0.75	75.5	18.0	6.0	4.9	4.31	12.5	* 123379			
8	1.00	93.0	12.0	6.0	4.9	7.05	20.0	104587			
10	1.00	99.0	14.0	7.0	5.5	9.05	22.0	104570			
∅ d ₁ MF	P	l ₁₁	l ₂	d ₂	α	d ₁₀	l ₁₀	ID			
12	1.50	106.0	16.0	9.0	7.0	10.55	25.0	142825			
16	1.50	123.0	16.0	12.0	9.0	14.55	32.0	142826			
20	1.50	132.0	18.0	16.0	12.0	18.55	36.0	111844			
25	1.50	155.0	22.0	18.0	14.5	23.55	45.0	111845			
32	1.50	170.0	24.0	22.0	18.0	30.55	50.0	111846			

UNC ANSI B1.1 G DIN ISO 228 PG DIN 40430

HSSE



N5951

N5951

2B

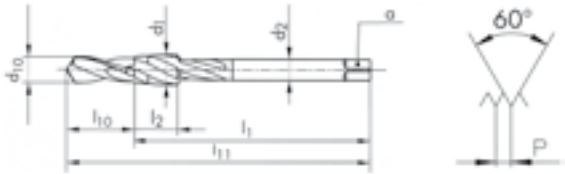

Ø" d ₁ UNC	P TPI	d ₁ mm	l ₁₁ mm	l ₂ mm	d ₂ mm	a mm	d ₁₀ mm	l ₁₀ mm
6	32	3.50	66.0	16.0	4.0	3.0	2.80	10.0
10	24	4.82	75.5	18.0	4.5	3.4	3.86	12.5
1/4	20	6.35	81.0	20.0	7.0	5.5	5.15	14.0
1/2	13	12.70	106.0	16.0	9.0	7.0	10.85	25.0

ID

* 104601
* 104598
* 104597
* 104596

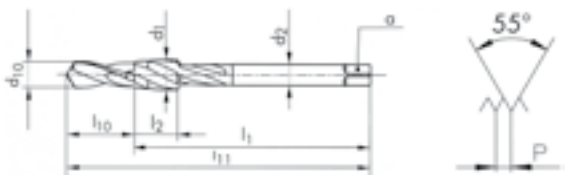

Ø" d ₁ G	P TPI	d ₁ mm	l ₁₁ mm	l ₂ mm	d ₂ mm	a mm	d ₁₀ mm	l ₁₀ mm
1/8	28	9.72	93.0	12.0	7.0	5.5	8.75	20.0
1/4	19	13.15	106.0	14.0	11.0	9.0	11.75	25.0
3/8	19	16.66	123.0	16.0	12.0	9.0	15.25	32.0
1/2	14	20.95	132.0	18.0	16.0	12.0	19.00	36.0
3/4	14	26.44	155.0	22.0	18.0	14.5	24.45	45.0

ID

104567
104566
104569
104565
* 104568

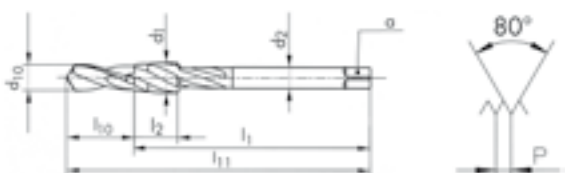

Ø d ₁ PG	P TPI	d ₁ mm	l ₁₁ mm	l ₂ mm	d ₂ mm	a mm	d ₁₀ mm	l ₁₀ mm
7	20	12.50	106.0	14.0	9.0	7.0	11.40	25.0
9	18	15.20	114.0	15.0	12.0	9.0	13.95	28.0
13.5	18	20.40	132.0	18.0	16.0	12.0	19.15	36.0
16	18	22.50	142.0	20.0	18.0	14.5	21.25	40.0
29	16	37.00	203.0	28.0	28.0	22.0	35.65	63.0

ID

* 104594
* 104595
* 104590
* 104591
* 104593



KODIERUNG - CODIFICATION

DC VHM-Gewindewirbler DC Solid carbide thread whirl cutters



Beispiel - Example

Gewindewirbler	Thread whirl cutter	GW					
Einzahn	Single tooth		10				
Mehr Zahn-Einzelprofil	Single profile, multi toothed		20				
Mehr Zahn-Doppelprofil	Double pitch with multi flutes		30				
Mehr Zahn-Vollprofil	Multi fluted with full profile		40				
Gewindelänge 2.5 x D ₁	Thread length 2.5 x D ₁			16			
Gewindelänge 4 x D ₁	Thread length 4 x D ₁			19			
Verschleisschutzschicht	Wear-protective coating					VS	
Spezialausführung	Special execution						SP































DC VHM-Gewindefräser DC Solid carbide thread milling cutters



Beispiel - Example

Standardausführung	Standard execution	GF					
Für gehärteten Stahl (55 - 63 HRC)	For hardened steels (55 - 63 HRC)	GFH					
Mit 45° Senkfase	With 45° chamfer for countersinking	GFS					
Polyvalenter Gewindefräser	For multi sizes thread milling cutters	GFM					
Bohrgewindefräser	Thrillers	BGF					
Spiralnuten 27° (GF), 10° (GFH)	Spiral flutes 27° (GF), 10° (GFH)		61				
Spiralnuten 27° (GFS)	Spiral flutes 27° (GFS)		66				
Spiralnuten 15° (GFM)	Spiral flutes 15° (GFM)		62				
Bohrgewindefräser zweilippig	Thrillers 2 flutes		67				
Bohrgewindefräser dreilippig	Thrillers 3 flutes		68				
Aussenkühlung	External lubrication				1		
Innenkühlung	Internal lubrication				6		
Gewindelänge 1.5 x D ₁	Thread length 1.5 x D ₁					0	
Gewindelänge 2 x D ₁	Thread length 2 x D ₁					5	
Gewindelänge 2.5 x D ₁	Thread length 2.5 x D ₁					6	
Verschleisschutzschicht	Wear-protective coating						VS
Spezialausführung	Special execution						SP

Piktogramme - Pictographs

	Vollhartmetall Solid carbide		Gewindelänge 1.5 x D ₁ Thread length 1.5 x D ₁
	10° Rechtsspiralnuten 10° right hand spiral flutes		Gewindelänge 2 x D ₁ Thread length 2 x D ₁
	15° Rechtsspiralnuten 15° right hand spiral flutes		Gewindelänge 2.5 x D ₁ Thread length 2.5 x D ₁
	27° Rechtsspiralnuten 27° right hand spiral flutes		Innengewinde Internal thread
	27° Rechtsspiralnuten 27° right hand spiral flutes		Aussengewinde External thread
	Mit 45° Senker zum Anfasen des Gewindes With 45° chamfer for countersinking		Sacklöcher (BGF) Blind holes (BGF)
	Anzahl Spannuten (Z) Number of flutes (Z)		Durchgangslöcher (BGF) Through holes (BGF)
	Kühlkanal Internal cooling channel		BGF, 2 Spannuten BGF, 2 flutes
	Kühlkanal (BGF, 2 Spannuten) Internal cooling channel (BGF, 2 flutes)		BGF, 3 Spannuten BGF, 3 flutes
	Kühlkanal (BGF, 3 Spannuten) Internal cooling channel (BGF, 3 flutes)		Für Werkstoffe ≤ 63 HRC (GFH) For materials ≤ 63 HRC (GFH)
	DC -Verschleisschutzschicht DC wear-protective coating		Konisches Gewinde 1:16 (NPT - NPTF) Tapered thread 1:16 (NPT - NPTF)
	EG-Gewinde Thread EG (for wire screw thread inserts)		Rundlaufgenauigkeit Shape accuracy
	Gewindelänge 2.5 x D ₁ Thread length 2.5 x D ₁		Toleranzklasse h5 Tolerance class h5
	Gewindelänge 4 x D ₁ Thread length 4 x D ₁		Drallwinkel Helix angle
	Kernlochdurchmesser Core hole diameter		Schweizerische Uhrenindustrie-Norm Norm of Swiss Watch Industry

Bemerkung GFM

 Zur Vermeidung grösserer Profilüberfräsungen darf der Fräser-Ø für Regelgewinde nicht grösser als 2/3 (Feingewinde 3/4) des zu fräsenden Gewinde-Ø sein.

Notice GFM

 In order to avoid profile defects it is important that the tool diameter does not exceed 2/3 of the diameter of the work-piece thread for coarse threads (3/4 for fine threads).

VORTEILE - ADVANTAGES

GW-GF-GFH-GFS-GFM

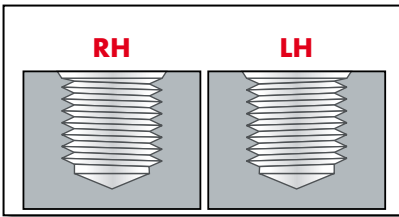

Ein einziger Gewindefräser für Rechts- und Linksgewinde
The same cutter can be used for right and left hand threads

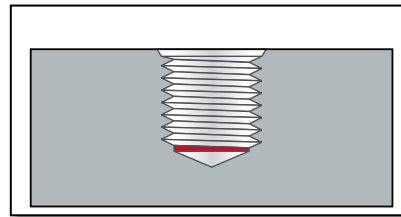

Für Gewinde bis fast auf den Grund der Vorbohrung
For threads to be cut near to the bottom of blind holes

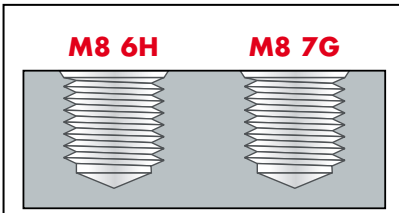

Je nach Wahl, gewünschte Toleranz einstellbar
Required tolerance adjustable as per users choice

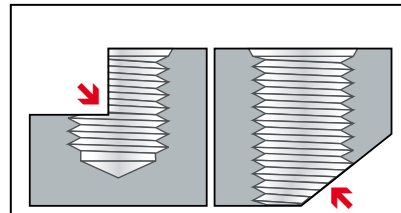

Für Gewinde mit unterbrochenem Schnitt, mit schrägem Anschnitt oder Austritt
For threads with interrupted cut or with oblique entrance or exit

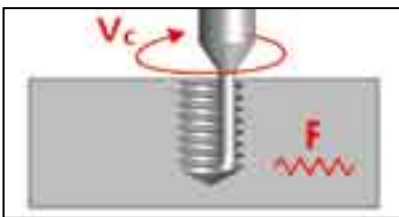

Schnittgeschwindigkeit und Vorschub können dem zu bearbeitenden Werkstoff individuell angepasst werden.
The cutting speed and feed rate can be matched individually to each work-piece material.

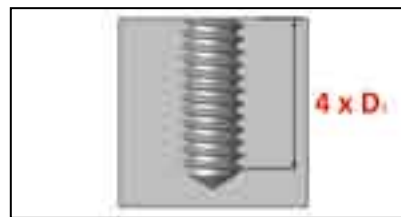

Ideal für tiefe Sacklöcher.
Ideal for deep blind holes.

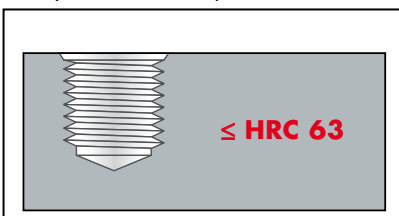

Gewinde in hochfeste Werkstoffe können realisiert werden
To realise threads in hardened materials

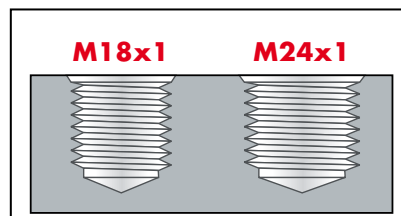

Ein einziger Gewindefräser für einen grossen Durchmesserbereich
One only tool for threads of a wide range of diameters with the same pitch

BGF

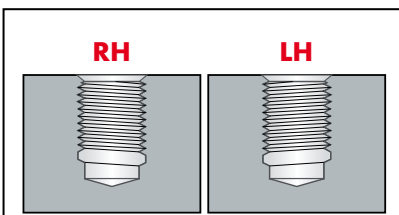

Ein einziger Gewindefräser für Rechts- und Linksgewinde
The same cutter can be used for right and left hand threads

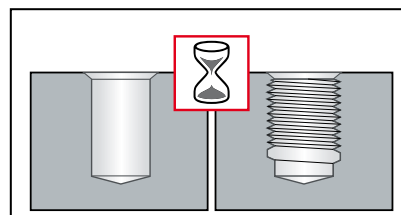

Platzgewinn im Werkzeugmagazin der Maschine und Einsparung von Bearbeitungszeit
Time-saving when tool changing and space-saving in the tool carousel

PROGRAMMIERZYKLUS - PROGRAMMING CYCLE

Rechtsgewinde im Gleichlauf - Right hand thread climb milling

GW1016
GW1016VS
GW2016
GW2016VS

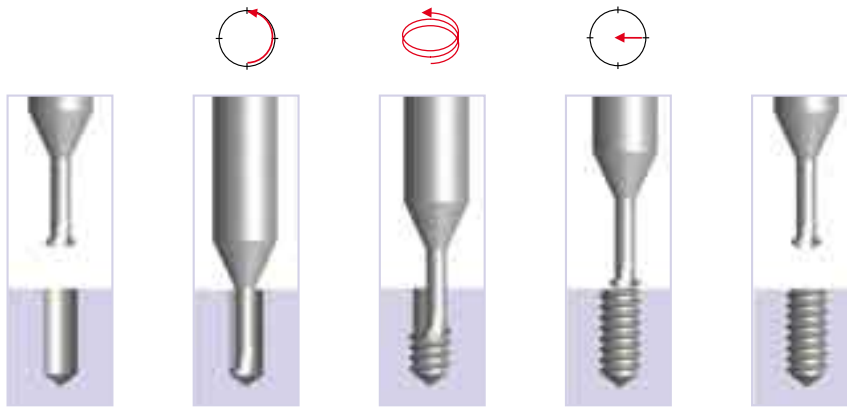

Rechtsgewinde im Gegenlauf - Conventional right hand thread milling

GW3016
GW3016VS
GW3019
GW3019VS
GW4016
GW4016VS
GW4019
GW4019VS

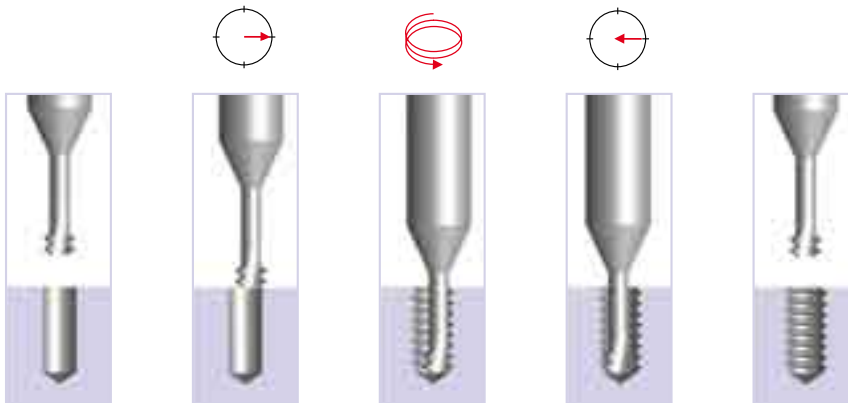

Programmierzklus für Typ GF - Operating cycle type GF

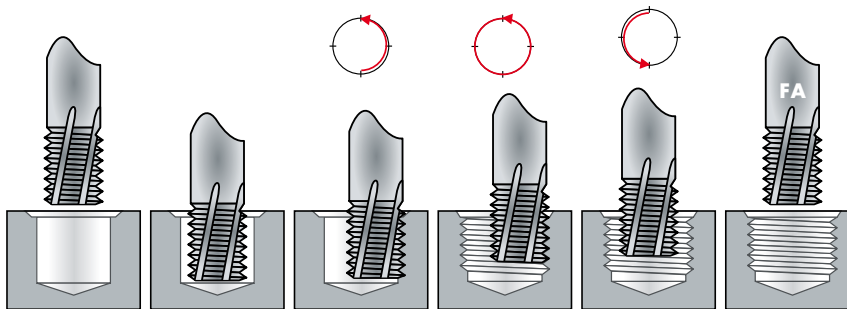

Programmierzklus für Typ BGF - Operating cycle type BGF

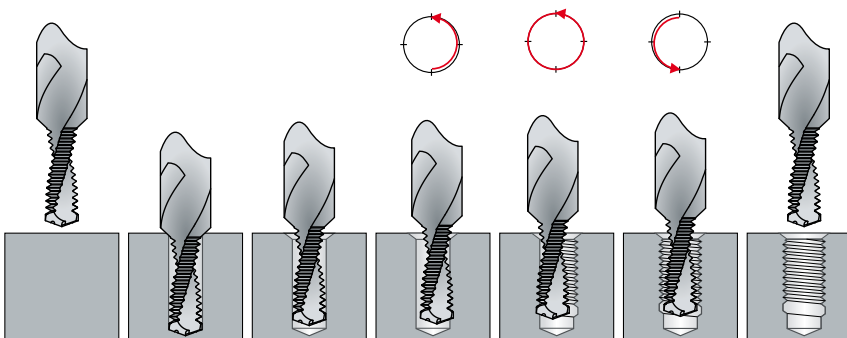

SCHNITTGESCHWINDIGKEITEN UND VORSCHÜBE

CUTTING SPEEDS AND FEED RATES

Besondere Anforderungen – Specific requirements



CNC-Bearbeitungsmaschine
mit 3-Achsen-Bahnsteuerung

CNC machine with 3-D continuous
path control



HSC-Bearbeitung

High speed cutting

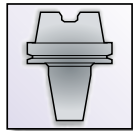

Absoluter Rundlauf des Auf-
spannfutters

Perfect concentricity of fixture

DC -Anwendungstabelle für Gewindewirbler

DC Application chart for thread whirling

Werkstoff-Gruppen Material groups	Werkstoffbezeichnung	Material designation	Härte Hardness (HB)	Festigkeit Tensile strength Rm (N/mm ²)
10 Stahl Steels	11 Automatenstahl	Free-cutting steels	< 200	< 700
	12 Baustahl, Einsatzstahl	Structural / cementation steels	< 200	< 700
	13 Kohlenstoffstahl	Carbon steels	< 300	<1000
	14 Stahl legiert <850 N/mm ²	Alloy steels <850 N/mm ²	< 250	< 850
	15 Stahl legiert / vergütet >850 - <1150 N/mm ²	Alloy steels hard./ temp. >850 - <1150 N/mm ²	> 250	> 850
	16 Hochfester Stahl <55 HRC	High tensile alloy steels <55 HRC	> 250	> 850
20 Rostfreier Stahl Stainless Steels	21 Rostfreier Stahl / geschwefelt	Free machining stainless steels	< 250	< 850
	22 Austenitisch	Austenitic stainless steels	< 250	< 850
	23 Ferritisch, martensitisch <850 N/mm ²	Ferritic and martensitic <850 N/mm ²	< 250	< 850
	24 Ferritisch, martensitisch >850 - <1150 N/mm ²	Ferritic and martens. >850 - <1150 N/mm ²	> 250	> 850
30 Guss Cast iron	31 Grauguss	Cast iron	< 250	< 850
	32 Kugelgraphitguss	Spheroidal graphite + malleable cast iron	< 250	< 850
40 Titan Titanium	41 Reintitan	Pure titanium	< 250	< 850
	42 Titanlegierung	Titanium alloys	> 250	> 850
50 Nickel Nickel	51 Nickellegierung 1 <850 N/mm ²	Nickel alloys 1 <850 N/mm ²	< 250	< 850
	52 Nickellegierung 2 >850 - <1150 N/mm ²	Nickel alloys 2 >850 - <1150 N/mm ²	> 250	> 850
	53 Nickellegierung 3 >1150 - ≤1600 N/mm ²	Nickel alloys 3 >1150 - ≤1600 N/mm ²	> 340	> 1150
60 Kupfer Copper	61 Reinkupfer (Elektrolytkupfer)	Pure copper (electrolytic copper)	< 120	< 400
	62 Messing, Bronze, Rotguss (kurzspanend)	Short chip brass, phosphor bronze, gun metal	< 200	< 700
	63 Messing (langspanend)	Long chip brass	< 200	< 700
70 Aluminium Magnesium Aluminium Magnesium	71 Al unlegiert	Al unalloyed	< 100	< 350
	72 Al legiert Si < 1.5 %	Al alloyed Si < 1.5 %	< 150	< 500
	73 Al legiert Si > 1.5 % - < 10 %	Al alloyed Si > 1.5 % - < 10 %	< 120	< 400
	74 Al legiert Si > 10 %, Mg-Legierung	Al alloyed Si > 10 %, Mg-Alloys	< 120	< 400
80 Kunststoff Plastic compounds	81 Thermoplaste	Thermoplastics	-	-
	82 Duroplaste	Duroplastics	-	-
	83 Faserverstärkte Kunststoffe	Glass fibre reinforced plastics	-	-
90 Edelm. - M. Prec.	91 Gelbgold	Yellow gold	-	-
	92 Rotgold	Red gold	-	-
	93 Weissgold	White gold	-	-
	94 Silber	Silver	-	-

Einsatz – Use

S Optimal mit Schneidöl
S Geeignet mit Schneidöl

S Optimal with cutting oil
S Suitable with cutting oil

E Optimal mit Emulsion
E Geeignet mit Emulsion

E Optimal with emulsion
E Suitable with emulsion

GW

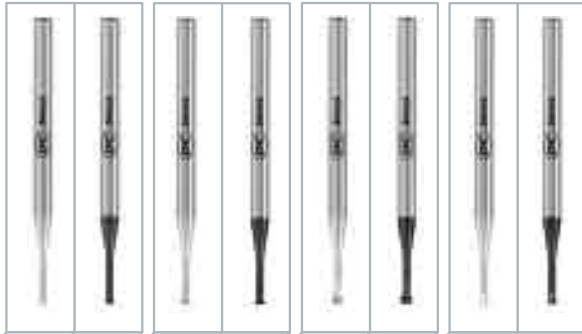

GW1016



GW2016

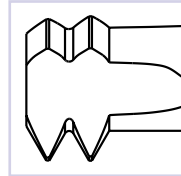

GW3016/19

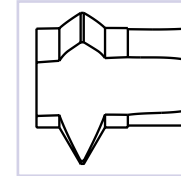

GW4016/19

		Vc (m/min)		Vorschub fz (mm/Zahn)		Milling fz (mm/tooth)		
		Standard	Beschichtet	∅ 0.3 - 1.0	∅ 1.01 - 3.0	∅ 3.01 - 6.0	∅ 6.01 - 12.0	
GW1016	GW1016S	60 - 80	80 - 100	0.004 - 0.01	0.01 - 0.05	0.04 - 0.10	0.08 - 0.15	11
GW2016	GW2016S	60 - 80	80 - 100	0.004 - 0.01	0.01 - 0.05	0.04 - 0.10	0.08 - 0.15	12
GW3016	GW3016S	50 - 70	70 - 90	0.004 - 0.01	0.01 - 0.05	0.02 - 0.10	0.05 - 0.15	13
GW3019	GW3019S	50 - 70	70 - 90	0.004 - 0.01	0.01 - 0.05	0.02 - 0.10	0.05 - 0.15	14
GW4016	GW4016S	15 - 35	30 - 50	0.004 - 0.01	0.01 - 0.05	0.02 - 0.08	0.04 - 0.15	15
GW4019	GW4019S	15 - 35	30 - 50	0.003 - 0.01	0.006 - 0.03	0.008 - 0.05	0.01 - 0.08	16
			40 - 60	0.004 - 0.01	0.01 - 0.05	0.02 - 0.10	0.05 - 0.15	21
			30 - 50	0.004 - 0.01	0.01 - 0.03	0.02 - 0.05	0.03 - 0.08	22
			30 - 50	0.004 - 0.01	0.01 - 0.03	0.02 - 0.05	0.03 - 0.08	23
			30 - 50	0.004 - 0.01	0.01 - 0.03	0.02 - 0.05	0.03 - 0.08	24
		60 - 90	90 - 120	0.004 - 0.01	0.01 - 0.05	0.04 - 0.10	0.08 - 0.15	31
		50 - 70	70 - 90	0.004 - 0.01	0.01 - 0.05	0.02 - 0.10	0.05 - 0.15	32
		15 - 35	20 - 40	0.004 - 0.01	0.01 - 0.03	0.02 - 0.05	0.03 - 0.08	41
		10 - 30	15 - 35	0.004 - 0.01	0.01 - 0.03	0.02 - 0.05	0.03 - 0.08	42
			20 - 40	0.004 - 0.01	0.01 - 0.03	0.02 - 0.05	0.03 - 0.08	51
			20 - 40	0.004 - 0.01	0.01 - 0.03	0.02 - 0.05	0.03 - 0.08	52
			20 - 30	0.003 - 0.01	0.006 - 0.03	0.008 - 0.05	0.01 - 0.08	53
		150 - 200	200 - 250	0.004 - 0.01	0.01 - 0.05	0.02 - 0.10	0.05 - 0.15	61
		100 - 150	150 - 200	0.004 - 0.01	0.01 - 0.05	0.04 - 0.10	0.08 - 0.15	62
		100 - 150	150 - 200	0.004 - 0.01	0.01 - 0.05	0.02 - 0.10	0.05 - 0.15	63
		150 - 250		0.004 - 0.01	0.01 - 0.05	0.05 - 0.10	0.10 - 0.20	71
		150 - 250		0.004 - 0.01	0.01 - 0.05	0.05 - 0.10	0.10 - 0.20	72
		150 - 250	200 - 300	0.004 - 0.01	0.01 - 0.05	0.05 - 0.10	0.10 - 0.20	73
		150 - 250	200 - 300	0.004 - 0.01	0.01 - 0.05	0.04 - 0.10	0.08 - 0.15	74
		150 - 250	200 - 300	0.004 - 0.01	0.01 - 0.05	0.05 - 0.10	0.10 - 0.20	81
		80 - 150	100 - 200	0.004 - 0.01	0.01 - 0.05	0.04 - 0.10	0.08 - 0.15	82
			80 - 100	0.004 - 0.01	0.01 - 0.05	0.04 - 0.10	0.08 - 0.15	83
		100 - 150	150 - 200	0.004 - 0.01	0.01 - 0.05	0.04 - 0.10	0.08 - 0.15	91
		60 - 90	90 - 120	0.004 - 0.01	0.01 - 0.05	0.02 - 0.10	0.04 - 0.15	92
			30 - 50	0.004 - 0.01	0.01 - 0.03	0.02 - 0.05	0.03 - 0.08	93
		60 - 90	90 - 120	0.004 - 0.01	0.01 - 0.05	0.02 - 0.10	0.04 - 0.15	94

Bei den oben aufgeführten Daten handelt es sich um Richtwerte. The indicated values are a guideline.

SCHNITTGESCHWINDIGKEITEN UND VORSCHÜBE

CUTTING SPEEDS AND FEED RATES

DC -Anwendungstabelle für Gewindefräser und Bohrgewindefräser

DC Application chart for thread milling cutters and thrillers

Werkstoff-Gruppen Material groups	Werkstoffbezeichnung Für Werkstoffbeispiele siehe Seiten 5 - 6.	Material designation Examples for application groups, pag. 5 - 6.	Härte Hardness (HB)	Festigkeit Tensile strength Rm (N/mm ²)
10 Stahl Steels	11 Automatenstahl	Free-cutting steels	< 200	< 700
	12 Baustahl, Einsatzstahl	Structural / cementation steels	< 200	< 700
	13 Kohlenstoffstahl	Carbon steels	< 300	< 1000
	14 Stahl legiert <850 N/mm ²	Alloy steels <850 N/mm ²	< 250	< 850
	15 Stahl legiert / vergütet >850 - <1150 N/mm ²	Alloy steels hard. / temp. >850 - <1150 N/mm ²	> 250	> 850
	16 Hochfester Stahl	High tensile alloy steels	> 250	> 850
	* Hochfester Stahl 55 - 63 HRC	High tensile alloy steels 55 - 63 HRC	> 560	> 2000
20 Rostfreier Stahl Stainless Steels	21 Rostfreier Stahl / geschwefelt	Free machining stainless steels	< 250	< 850
	22 Austenitisch	Austenitic stainless steels	< 250	< 850
	23 Ferritisch, martensitisch <850 N/mm ²	Ferritic and martensitic <850 N/mm ²	< 250	< 850
	24 Ferritisch, martensitisch >850 - <1150 N/mm ²	Ferritic and martens. >850 - <1150 N/mm ²	> 250	> 850
30 Guss Cast iron	31 Grauguss	Cast iron	< 250	< 850
	32 Kugelgraphitguss, Temperguss	Spheroidal graphite + malleable cast iron	< 250	< 850
40 Titan Titanium	41 Reintitan	Pure titanium	< 250	< 850
	42 Titanlegierung	Titanium alloys	> 250	> 850
50 Nickel Nickel	51 Nickellegierung 1 <850 N/mm ²	Nickel alloys 1 <850 N/mm ²	< 250	< 850
	52 Nickellegierung 2 >850 - <1150 N/mm ²	Nickel alloys 2 >850 - <1150 N/mm ²	> 250	> 850
	53 Nickellegierung 3 >1150 - ≤1600 N/mm ²	Nickel alloys 3 >1150 - ≤1600 N/mm ²	> 340	> 1150
60 Kupfer Copper	61 Reinkupfer (Elektrolytkupfer)	Pure copper (electrolytic copper)	< 120	< 400
	62 Messing, Bronze, Rotguss (kurzspanend)	Short chip brass, phosphor bronze, gun metal	< 200	< 700
	63 Messing (langspanend)	Long chip brass	< 200	< 700
70 Aluminium Magnesium Aluminium Magnesium	71 Al unlegiert	Al / Mg unalloyed	< 100	< 350
	72 Al legiert Si < 1.5 %	Al alloyed Si < 1.5 %	< 150	< 500
	73 Al legiert Si > 1.5 % - < 10 %	Al alloyed Si > 1.5 % - < 10 %	< 120	< 400
	74 Al legiert Si > 10 %, Mg-Legierung	Al alloyed Si > 10 %, Mg-Alloys	< 120	< 400
80 Kunststoff Plastic compounds	81 Thermoplaste	Thermoplastics	-	-
	82 Duroplaste	Duroplastics	-	-
	83 Faserverstärkte Kunststoffe	Glass fibre reinforced plastics	-	-

* Gewindefräser Typ GFH

Thread milling cutter type GFH

Formel zur Berechnung des "Fräsvorschubes"

$$\text{Vorschub} \quad V_{fk} = f_z \times Z \times n$$

$$\text{Vorschub der Werkzeugmitte} \quad V_{fm} = \frac{V_{fk} \times (\text{Nenndurchmesser des Gewindes} - \text{Fräserdurchmesser})}{\text{Nenndurchmesser des Gewindes}}$$

Auf CNC-Maschinen, die den Vorschub der Werkzeugmitte nicht automatisch berechnen, muss der Wert "Vorschub Werkzeugmitte V_{fm} " berücksichtigt werden.













































Thread milling feed rates

$$\text{Feed rate} \quad V_{fk} = f_z \times Z \times n$$













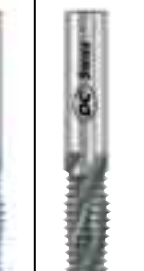

$$\text{Feed rate of the tool middle} \quad V_{fm} = \frac{V_{fk} \times (\text{nominal thread } \varnothing - \varnothing \text{ of the thread milling cutter})}{\text{nominal thread } \varnothing}$$

On CNC machines, which do not calculate for themselves the feed rate at the tool-centre, the value "centre of the tool V_{fm} " must be considered.















Inhaltsverzeichnis - VHM-Gewindewirbler Typ GW
Directory - Solid carbide thread whirl cutters type GW

		GW											
Typ Type		GW1016	GW1016VS	GW2016	GW2016VS	GW3016	GW3016VS	GW3019	GW3019VS	GW4016	GW4016VS	GW4019	GW4019VS
Beschichtung Coating			VS		VS		VS		VS		VS		VS
													
Gewindelänge Thread length													
Merkmale Characteristics													
													
M	ISO DIN 13 ISO DIN 14			207		208/209		208/209		212		212	
MF	ISO DIN 13					208/209		208/209					
UNC	ANSI B1.1					210		210		213		213	
UNF	ANSI B1.1					211		211		213		213	
S	NIHS	206		207									

Inhaltsverzeichnis - VHM-Gewindefräser Typ GF
Directory - Solid carbide thread milling cutters type GF

		GF											
Typ Type		GF6110	GF6110VS	GF6160	GF6160VS	GF6115	GF6115VS	GF6165	GF6165VS	GF6116	GF6116VS	GF6166	GF6166VS
Beschichtung Coating		VS		VS		VS		VS		VS		VS	
													
Gewindelänge Thread length													
Merkmale Characteristics													
M	ISO DIN 13	214				215		215		216		216	
MF	ISO DIN 13	217						218				218	
UNC	ANSI B1.1	219						220				220	
UNF	ANSI B1.1	221						222				222	
UN	ANSI B1.1												
G (BSP)	DIN ISO 228							223				223	
PG	DIN 40430												
NPT	ANSI B1.20.1			224									
NPTF	ANSI B1.20.3			224									
EG M	DIN 8140												

Inhaltsverzeichnis - VHM-Gewindfräser Typ GFH und GFS
Directory - Solid carbide thread milling cutters type GFH and GFS

		GFH		GFS							
Typ Type		GFH6110VS	GFS6610 GFS6610VS	GFS6660 GFS6660VS	GFS6615 GFS6615VS	GFS6665 GFS6665VS	GFS6616 GFS6616VS	GFS6666 GFS6666VS	GFS6616 GFS6616VS	GFS6666 GFS6666VS	
Beschichtung Coating											
Gewindelänge Thread length											
Merkmale Characteristics											
M	ISO DIN 13	214	225	225	226	226	227				
MF	ISO DIN 13		228	228	229	229					
UNC	ANSI B1.1		230	230	231	231					
UNF	ANSI B1.1		232	232	233	233					
UN/EF/S	ANSI B1.1										
G (BSP)	DIN ISO 228			234		234					
PG	DIN 40430										
NPT	ANSI B1.20.1			235							
NPTF	ANSI B1.20.3			235							
EG M	DIN 8140										

Inhaltsverzeichnis - VHM-Gewindefräser und VHM-Bohrgewindefräser Typ GFM und BGF
Directory - Solid carbide thread milling cutters and thrillers type GFM and BGF

		GFM		BGF									
GFS6666	GFS6666VS	GFM6260	GFM6260VS	BGF6760	BGF6760VS	BGF6765	BGF6765VS	BGF6766	BGF6766VS	BGF6865	BGF6865VS	BGF6866	BGF6866VS
VS		VS		VS		VS		VS		VS		VS	
227		236		240		241		241		242		242	
		236		243		243							
		237											
		237											
		237											
		238											
		239											
		239											

GW

GW1016



GW1016VS



GW1016

GW1016VS

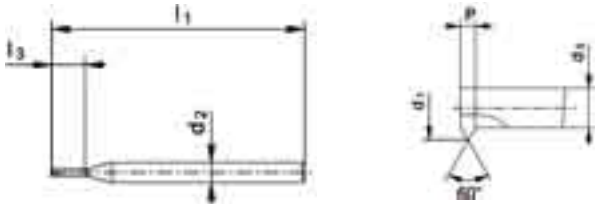

$\varnothing D_1$ S	P mm	d_1 mm	l_1 mm	l_3 mm	d_2 h5 mm	d_3 mm		
0.3	0.08	0.21	39	0.9	3	0.10	1	0.23 *
0.4	0.10	0.29	39	1.2	3	0.15	1	0.32 *
0.5	0.125	0.36	39	1.5	3	0.19	1	0.40 *
0.6	0.15	0.43	39	1.7	3	0.23	1	0.48 *
0.7	0.175	0.50	39	2.0	3	0.27	1	0.56 *
0.8	0.20	0.57	39	2.3	3	0.31	1	0.64 *
0.9	0.225	0.64	39	2.6	3	0.34	1	0.72 *
1.0	0.25	0.71	39	2.9	3	0.38	1	0.80 *
1.2	0.25	0.91	39	3.4	3	0.58	1	1.00 *
1.4	0.30	1.06	39	3.9	3	0.66	1	1.15 *

ID

ID

166930

166940

166931

166941

166932

166942

166933

166943

166934

166944

166935

166945

166936

166946

166937

166947

166938

166948

166939

166949

*Tol. +0.02 mm
0

GW

GW2016



GW2016VS



GW2016

GW2016VS

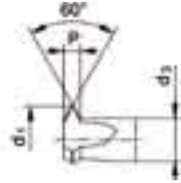
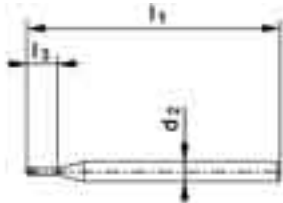

∅ D ₁	P	d ₁	l ₁	l ₃	d ₂ h5	d ₃		
S	mm	mm	mm	mm	mm	mm		→ ←

0.8	0.20	0.57	39	2.3	3	0.29	3	0.64 *
0.9	0.225	0.64	39	2.6	3	0.33	3	0.72 *
1.0	0.25	0.71	39	2.9	3	0.36	3	0.80 *
1.2	0.25	0.91	39	3.4	3	0.56	3	1.00 *
1.4	0.30	1.06	39	3.9	3	0.64	3	1.15 *

ID

ID

166969	166988
166970	166989
166971	166990
166972	166991
166973	166992

∅ D ₁	P	d ₁	l ₁	l ₃	d ₂ h5	d ₃		
M	mm	mm	mm	mm	mm	mm		→ ←

0.8	0.20	0.57	39	2.3	3	0.29	3	0.62
0.9	0.225	0.64	39	2.6	3	0.33	3	0.70
1.0	0.25	0.71	39	2.9	3	0.36	3	0.75
1.2	0.25	0.91	39	3.4	3	0.56	3	0.95
1.4	0.30	1.06	39	3.9	3	0.64	3	1.10
1.6	0.35	1.20	39	4.5	3	0.71	3	1.25
1.8	0.35	1.40	39	5.0	3	0.91	3	1.45
2.0	0.40	1.54	39	5.6	3	0.98	3	1.60
2.5	0.45	1.98	39	6.9	3	1.35	3	2.05
3.0	0.50	2.43	51	8.4	5	1.73	4	2.50
3.5	0.60	2.81	51	9.9	5	1.97	4	2.90
4.0	0.70	3.20	51	11.3	5	2.22	4	3.30
5.0	0.80	4.08	51	14.0	5	2.96	4	4.20
6.0	1.00	4.90	51	16.8	5	3.50	4	5.00

ID

ID

166974	166993
166975	166994
166976	166995
166977	166996
166978	166997
166979	166998
166980	166999
166981	167000
166982	167001
166983	167002
166984	167003
166985	167004
166986	167005
166987	167006

*Tol. +0.02 mm
0



h5

GW

GW3016



GW3016VS



GW3019



GW3019VS

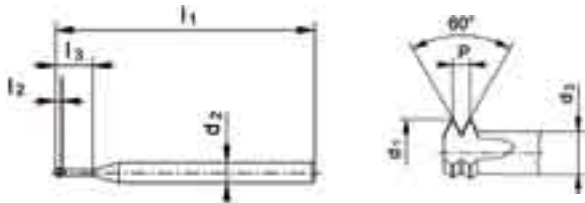

GW3016

GW3016VS

GW3019

GW3019VS



$\varnothing D_1$ M, MF	P	d_1	l_1	l_3	d_2 h5	d_3		
----------------------------	---	-------	-------	-------	----------	-------	--	--

0.8	0.20	0.57	39	2.3	3	0.29	3	0.62
0.9	0.225	0.64	39	2.6	3	0.33	3	0.70
1.0	0.25	0.71	39	2.9	3	0.36	3	0.75
1.2	0.25	0.91	39	3.4	3	0.56	3	0.95
1.4	0.30	1.06	39	3.9	3	0.64	3	1.10
1.6	0.35	1.20	39	4.5	3	0.71	3	1.25
1.8	0.35	1.40	39	5.0	3	0.91	3	1.45
2.0	0.20	1.77	39	5.3	3	1.49	3	1.80
2.0	0.40	1.54	39	5.6	3	0.98	3	1.60
2.5	0.20	2.27	39	6.6	3	1.99	3	2.30
2.5	0.25	2.21	39	6.6	3	1.86	3	2.25
2.5	0.45	1.98	39	6.9	3	1.35	3	2.05

ID

ID

$\varnothing D_1$ M, MF	P	d_1	l_1	l_3	d_2 h5	d_3		
----------------------------	---	-------	-------	-------	----------	-------	--	--

0.8	0.20	0.57	39	3.5	3	0.29	3	0.62
0.9	0.225	0.64	39	3.9	3	0.33	3	0.70
1.0	0.25	0.71	39	4.4	3	0.36	3	0.75
1.2	0.25	0.91	39	5.2	3	0.56	3	0.95
1.4	0.30	1.06	39	6.0	3	0.64	3	1.10
1.6	0.35	1.20	39	6.9	3	0.71	3	1.25
1.8	0.35	1.40	39	7.7	3	0.91	3	1.45
2.0	0.20	1.77	39	8.3	3	1.49	3	1.80
2.0	0.40	1.54	39	8.6	3	0.98	3	1.60
2.5	0.20	2.27	39	10.3	3	1.99	3	2.30
2.5	0.25	2.21	39	10.4	3	1.86	3	2.25
2.5	0.45	1.98	39	10.6	3	1.35	3	2.05

ID

ID

									167063	167077
									167064	167078
									167065	167079
									167066	167080
									167067	167081
									167068	167082
									167069	167083
									175254	175270
									167070	167084
									175255	175271
									175256	175272
									167071	167085

M, MF ISO DIN 13



h5

GW

GW3016



GW3016VS



GW3019



GW3019VS

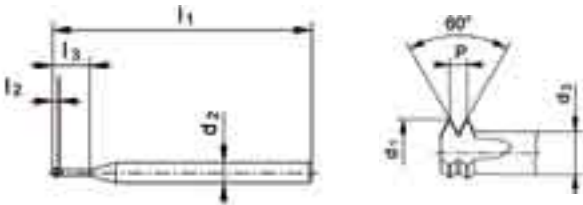

GW3016

GW3016VS

GW3019

GW3019VS



$\varnothing D_1$ M, MF	P mm	d_1 mm	l_1 mm	l_3 mm	d_2 h5 mm	d_3 mm		
3.0	0.35	2.60	51	8.2	5	2.11	4	2.65
3.0	0.50	2.43	51	8.4	5	1.73	4	2.50
3.5	0.60	2.81	51	9.9	5	1.97	4	2.90
4.0	0.70	3.20	51	11.3	5	2.22	4	3.30
5.0	0.80	4.08	51	14.0	5	2.96	4	4.20
6.0	1.00	4.85	51	16.8	5	3.45	4	5.00
8.0	1.25	5.95	63	23.0	6*	4.20	5	6.80
10.0	1.50	7.95	67	28.0	8*	5.85	5	8.50
12.0	1.75	9.95	76	34.0	10*	7.50	5	10.20

ID

ID

175228	175242
167030	167044
167031	167045
167032	167046
167033	167047
167034	167048
175229	175243
175230	175244
175231	175245

$\varnothing D_1$ M, MF	P mm	d_1 mm	l_1 mm	l_3 mm	d_2 h5 mm	d_3 mm		
3.0	0.35	2.60	51	12.7	5	2.11	4	2.65
3.0	0.50	2.43	51	12.9	5	1.73	4	2.50
3.5	0.60	2.81	51	15.1	5	1.97	4	2.90
4.0	0.70	3.20	51	17.3	5	2.22	4	3.30
5.0	0.80	4.08	51	21.5	5	2.96	4	4.20
6.0	1.00	4.85	51	25.8	5	3.45	4	5.00
8.0	1.25	5.95	75	35.0	6*	4.20	5	6.80
10.0	1.50	7.95	83	43.0	8*	5.85	5	8.50
12.0	1.75	9.95	95	52.0	10*	7.50	5	10.20

ID

ID

175257	175273
167072	167086
167073	167087
167074	167088
167075	167089
167076	167090
175258	175274
175259	175275
175260	175276

*Tol. h6

GW

GW3016



R10

GW3016VS



R10

VS

GW3019



R10

GW3019VS



R10

VS

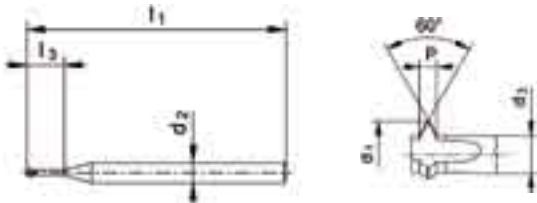

GW3016

GW3016VS

GW3019

GW3019VS



$\varnothing D_1$ UNC	P TPI	d_1 mm	l_1 mm	l_3 mm	d_2 h5 mm	d_3 mm		
2	56	1.66	39	6.1	3	1.02	3	1.75
4	40	2.11	39	8.0	3	1.22	3	2.25
6	32	2.59	51	10.2	5	1.48	4	2.75
8	32	3.25	51	11.9	5	2.14	4	3.40
10	24	3.60	51	14.0	5	2.12	4	3.80
1/4	20	4.89	51	18.2	5	3.11	4	5.10
5/16	18	5.95	63	23.0	6*	3.97	5	6.50
3/8	16	7.10	67	27.0	8*	4.87	5	8.00
1/2	13	9.95	76	36.0	10*	7.21	5	10.80

ID

ID

167472	167500
167473	167501
167474	167502
167475	167503
173983	173986
167476	167504
175232	175246
175233	173546
175234	175247

$\varnothing D_1$ UNC	P TPI	d_1 mm	l_1 mm	l_3 mm	d_2 h5 mm	d_3 mm		
2	56	1.66	39	9.4	3	1.02	3	1.75
4	40	2.11	39	12.2	3	1.22	3	2.25
6	32	2.59	51	15.5	5	1.48	4	2.75
8	32	3.25	51	18.1	5	2.14	4	3.40
10	24	3.60	51	21.3	5	2.12	4	3.80
1/4	20	4.89	51	27.7	5	3.11	4	5.10
5/16	18	5.95	75	35.0	6*	3.97	5	6.50
3/8	16	7.10	83	41.0	8*	4.87	5	8.00
1/2	13	9.95	95	55.0	10*	7.21	5	10.80

ID

ID

167479	167507
167480	167508
167481	167509
167482	167510
173982	173979
167483	167511
175261	175277
175262	175278
175263	175279

*Tol. h6

UNF ANSI B1.1



h5

GW

GW3016



GW3016VS



GW3019



GW3019VS

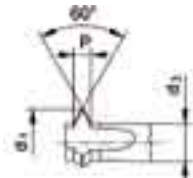
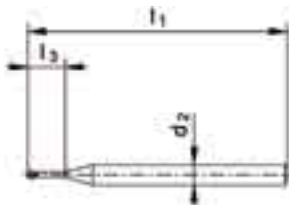

GW3016

GW3016VS

GW3019

GW3019VS



$\varnothing D_1$ UNF	P TPI	d_1 mm	l_1 mm	l_3 mm	d_2 h5 mm	d_3 mm		
0	80	1.15	39	4.3	3	0.71	3	1.20
1	72	1.44	39	5.1	3	0.95	3	1.50
4	48	2.23	39	7.9	3	1.49	3	2.35
8	36	3.35	51	11.7	5	2.36	4	3.50
10	32	3.91	51	13.5	5	2.80	4	4.05
1/4	28	4.95	51	17.6	5	3.68	4	5.50
5/16	24	5.95	63	22.0	6*	4.47	5	6.90
3/8	24	7.10	67	26.0	8*	5.62	5	8.50

ID

ID

$\varnothing D_1$ UNF	P TPI	d_1 mm	l_1 mm	l_3 mm	d_2 h5 mm	d_3 mm		
0	80	1.15	39	6.6	3	0.71	3	1.20
1	72	1.44	39	7.9	3	0.95	3	1.50
4	48	2.23	39	12.1	3	1.49	3	2.35
8	36	3.35	51	18.0	5	2.36	4	3.50
10	32	3.91	51	20.8	5	2.80	4	4.05
1/4	28	4.95	51	27.1	5	3.68	4	5.50
5/16	24	5.95	75	34.0	6*	4.47	5	6.90
3/8	24	7.10	83	40.0	8*	5.62	5	8.50

ID

ID

175235	175248
175236	175249
175237	175250
175238	175251
167477	167505
167478	167506
175239	175252
175240	175253
175264	175280
175265	175281
175266	172376
175267	175282
167484	167512
167485	167513
175268	175283
175269	175284

*Tol. h6

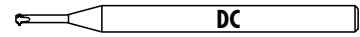

h5

GW

GW4016



GW4016VS



GW4019



GW4019VS

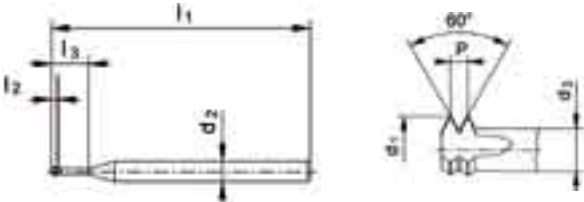

GW4016

GW4016VS

GW4019

GW4019VS



$\varnothing D_1$ M	P mm	d_1 mm	l_1 mm	l_2 mm	l_3 mm	d_2 h5 mm	d_3 mm		
0.8	0.20	0.51	39	0.40	2.3	3	0.23	3	0.58*
0.9	0.225	0.57	39	0.45	2.6	3	0.26	3	0.65*
1.0	0.25	0.64	39	0.50	2.9	3	0.29	3	0.70*
1.2	0.25	0.84	39	0.50	3.4	3	0.49	3	0.90*
1.4	0.30	0.97	39	0.60	4.0	3	0.55	3	1.05*
1.6	0.35	1.09	39	0.70	4.6	3	0.60	3	1.19*
1.8	0.35	1.29	39	0.70	5.1	3	0.80	3	1.39*
2.0	0.40	1.42	39	0.80	5.6	3	0.86	3	1.54*
2.5	0.45	1.85	39	0.90	7.0	3	1.22	3	1.98*
3.0	0.50	2.28	51	1.00	8.5	5	1.58	4	2.43*
3.5	0.60	2.63	51	1.20	10.0	5	1.79	4	2.80*
4.0	0.70	2.99	51	1.40	11.4	5	2.01	4	3.20*
5.0	0.80	3.84	51	1.60	14.1	5	2.72	4	4.10*
6.0	1.00	4.55	51	2.00	17.0	5	3.15	4	4.90*

ID

ID

$\varnothing D_1$ M	P mm	d_1 mm	l_1 mm	l_2 mm	l_3 mm	d_2 h5 mm	d_3 mm		
0.8	0.20	0.51	39	0.40	3.5	3	0.23	3	0.58*
0.9	0.225	0.57	39	0.45	4.0	3	0.26	3	0.65*
1.0	0.25	0.64	39	0.50	4.4	3	0.29	3	0.70*
1.2	0.25	0.84	39	0.50	5.2	3	0.49	3	0.90*
1.4	0.30	0.97	39	0.60	6.1	3	0.55	3	1.05*
1.6	0.35	1.09	39	0.70	7.0	3	0.60	3	1.19*
1.8	0.35	1.29	39	0.70	7.8	3	0.80	3	1.39*
2.0	0.40	1.42	39	0.80	8.6	3	0.86	3	1.54*
2.5	0.45	1.85	39	0.90	10.7	3	1.22	3	1.98*
3.0	0.50	2.28	51	1.00	13.0	5	1.58	4	2.43*
3.5	0.60	2.63	51	1.20	15.2	5	1.79	4	2.80*
4.0	0.70	2.99	51	1.40	17.4	5	2.01	4	3.20*
5.0	0.80	3.84	51	1.60	21.6	5	2.72	4	4.10*
6.0	1.00	4.55	51	2.00	26.0	5	3.15	4	4.90*

ID

ID

*Tol. +0.03 mm
0

167105	167119
167106	167120
167107	167121
167108	167122
167109	167123
167110	167124
167111	167125
167112	167126
167113	167127
167114	167128
167115	167129
167116	167130
167117	167131
167118	167132
167147	167161
167148	167162
167149	167163
167150	167164
167151	167165
167152	167166
167153	167167
167154	167168
167155	167169
167156	167170
167157	167171
167158	167172
167159	167173
167160	167174

UNC-UNF ANSI B1.1

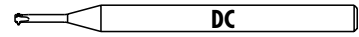

h5

GW

GW4016

GW4016VS

GW4019

GW4019VS

GW4016



GW4016VS



VS

GW4019



GW4019VS



VS

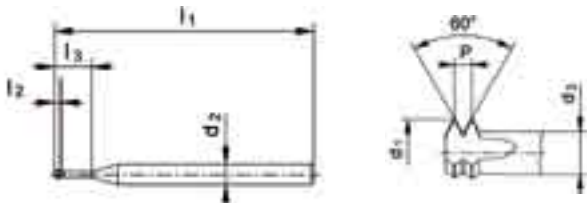

$\varnothing'' D_1$ UNC	P TPI	d_1 mm	l_1 mm	l_2 mm	l_3 mm	d_2 h5 mm	d_3 mm		
2	56	1.52	39	0.91	6.2	3	0.89	3	1.65*
4	40	1.92	39	1.27	8.1	3	1.03	3	2.10*
6	32	2.35	51	1.59	10.4	5	1.24	4	2.60*
1/4	20	4.51	51	2.54	18.5	5	2.73	4	5.00*

ID

ID

167486	167514
167487	167515
167488	167516
167490	167518

$\varnothing'' D_1$ UNF	P TPI	d_1 mm	l_1 mm	l_2 mm	l_3 mm	d_2 h5 mm	d_3 mm		
10	32	3.67	51	1.59	13.7	5	2.56	4	3.95*
1/4	28	4.95	51	1.81	17.7	5	3.68	4	5.35*

ID

ID

167491	167519
167492	167520

$\varnothing'' D_1$ UNC	P TPI	d_1 mm	l_1 mm	l_2 mm	l_3 mm	d_2 h5 mm	d_3 mm		
2	56	1.52	39	0.90	9.5	3	0.89	3	1.65*
4	40	1.92	39	1.27	12.4	3	1.03	3	2.10*
6	32	2.35	51	1.59	15.6	5	1.24	4	2.60*
1/4	20	4.51	51	2.54	28.0	5	2.73	4	5.00*

ID

ID

167493	167521
167494	167522
167495	167523
167497	167525

$\varnothing'' D_1$ UNF	P TPI	d_1 mm	l_1 mm	l_2 mm	l_3 mm	d_2 h5 mm	d_3 mm		
10	32	3.67	51	1.59	20.9	5	2.56	4	3.95*
1/4	28	4.95	51	1.81	27.3	5	3.68	4	5.35*

ID

ID

167498	167526
167499	167527

*Tol. $\begin{matrix} +0.03 \text{ mm} \\ 0 \end{matrix}$

GF - GFH

GF6110



GF6110VS



VS

GFH6110VS



VS

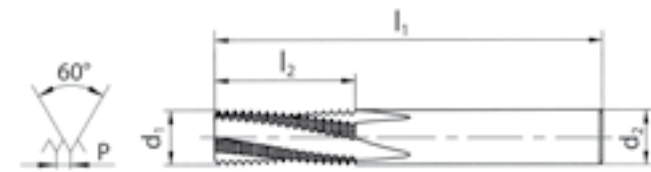

GF6110

GF6110VS

GFH6110VS



HRC
≤ 63



∅ D ₁ M	P mm	d ₁ mm	l ₁ mm	l ₂ mm	d ₂ mm	GF	GFH	
2	0.40	1.50	48	3.4	6	2		1.60
2.5	0.45	1.90	48	4.3	6	3		2.05
3	0.50	2.30	48	5.3	6	3	3	2.50
3.5	0.60	2.70	48	6.3	6	3		2.90
4	0.70	3.00	48	7.4	6	3	3	3.30
5	0.80	3.80	48	9.2	6	3	4	4.20
6	1.00	4.50	54	10.5	6		4	5.00
8	1.25	5.95	54	13.1	6		5	6.80
10	1.50	7.95	64	17.3	8		5	8.50
12	1.75	9.95	74	20.1	10		5	10.20

ID

ID

ID

125233

115993

150565

152124

125660

116395

150072

116350

135217

125944

116396

150073

126158

116397

150074

150075

150076

150077

151326



GF

GF6115



GF6115VS



VS

GF6165



GF6165VS



VS

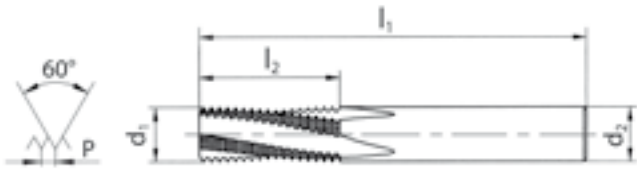

GF6115

GF6115VS

GF6165

GF6165VS



Ø D ₁ M	P mm	d ₁ mm	l ₁ mm	l ₂ mm	d ₂ mm		
4	0.70	3.00	48	8.8	6	3	3.30
5	0.80	3.80	48	10.8	6	3	4.20
6	1.00	4.50	54	13.5	6	3	5.00
8	1.25	5.95	54	18.1	6	3	6.80
10	1.50	7.95	64	21.8	8	4	8.50
12	1.75	9.95	72	25.4	10	4	10.20
14	2.00	9.95	74	31.0	10	4	12.00
16	2.00	11.95	80	35.0	12	4	14.00
18	2.50	13.95	90	41.3	14	4	15.50
20							17.50

ID

ID

ID

ID

146298

146969

146299

146970

146300

146971

126350

116398

146321

146972

126586

116399

146322

146973

124836

116400

116342

116401

125066

116402

125114

115990

125229

116403



GF

GF6116



GF6116VS



VS

GF6166



GF6166VS



VS

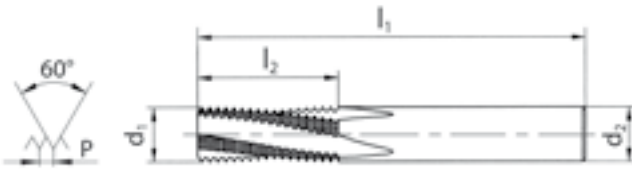

GF6116

GF6116VS

GF6166

GF6166VS



∅ D ₁ M	P mm	d ₁ mm	l ₁ mm	l ₂ mm	d ₂ mm		
4	0.70	3.00	48	10.9	6	3	3.30
5	0.80	3.80	48	13.2	6	3	4.20
6	1.00	4.50	54	16.5	6	3	5.00
8	1.25	5.95	54	21.9	6	3	6.80
10	1.50	7.95	64	26.3	8	4	8.50
12	1.75	9.95	74	32.4	10	4	10.20
14	2.00	9.95	74	37.0	10	4	12.00
16	2.00	11.95	90	43.0	12	4	14.00
18	2.50	13.95	105	53.8	14	4	15.50
20							17.50

ID

ID

ID

ID

155365

155370

155366

155371

155367

155372

155375

155382

155368

155373

155376

155383

155369

155374

155377

155384

155378

155385

155379

155386

155380

155387

155381

155388

GF

GF6110



GF6110VS



VS

GF6110

GF6110VS

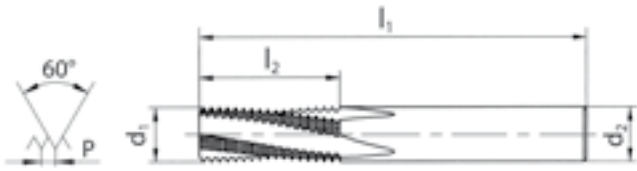

∅ D ₁ MF	P mm	d ₁ mm	l ₁ mm	l ₂ mm	d ₂ mm		
4	0.50	3.00	48	7.3	6	3	3.50
5	0.50	3.80	48	8.8	6	3	4.50

ID

ID

135218

135219

135069

135220



GF

GF6165

GF6165VS

GF6166

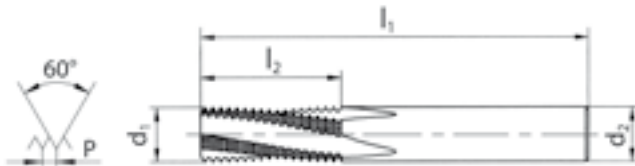
GF6166VS

GF6165
GF6165VS
GF6166
GF6166VS

∅ D ₁ MF	P mm	d ₁ mm	l ₁ mm	l ₂ mm	d ₂ mm		
6	0.50	4.50	54	12.8	6	3	5.50
6	0.75	4.50	54	13.1	6	3	5.25
8	0.50	5.95	54	17.8	6	3	7.50
8	0.75	5.95	54	16.9	6	3	7.25
8	1.00	5.95	54	17.5	6	3	7.00
10	1.00	7.95	64	21.5	8	4	9.00
10	1.25	7.95	64	21.9	8	4	8.80
12	1.00	9.95	72	25.5	10	4	11.00
12	1.50	9.95	72	26.3	10	4	10.50

ID
ID

135221	135222
123664	123665
135002	135223
143110	135224
124239	116404
119986	116405
120102	116406
120303	116407
120392	120393

∅ D ₁ MF	P mm	d ₁ mm	l ₁ mm	l ₂ mm	d ₂ mm		
6	0.50	4.50	54	15.8	6	3	5.50
6	0.75	4.50	54	16.1	6	3	5.25
8	0.50	5.95	54	20.8	6	3	7.50
8	0.75	5.95	54	20.6	6	3	7.25
8	1.00	5.95	54	21.5	6	3	7.00
10	1.00	7.95	64	26.5	8	4	9.00
10	1.25	7.95	64	26.9	8	4	8.80
12	1.00	9.95	74	31.5	10	4	11.00
12	1.50	9.95	74	32.3	10	4	10.50

ID
ID

155389	155398
155390	155399
155391	155400
155392	155401
155393	155402
155394	155403
155395	155404
155396	155405
155397	155406



GF

GF6110



GF6110VS



GF6110

GF6110VS

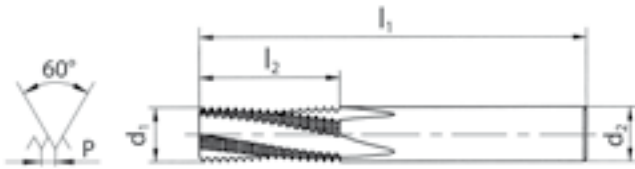

Ø" D ₁ UNC	P TPI	d ₁ mm	l ₁ mm	l ₂ mm	d ₂ mm		
10	24	3.60	48	10.1	6.0	3	3.80
12	24	4.10	48	10.1	6.0	3	4.40
1/4	20	4.80	54	12.1	6.0	3	5.10

ID

ID

135225

135226

135227

135228

135229

135230

GF

GF6165



GF6165VS



GF6166



GF6166VS



GF6165

GF6165VS

GF6166

GF6166VS

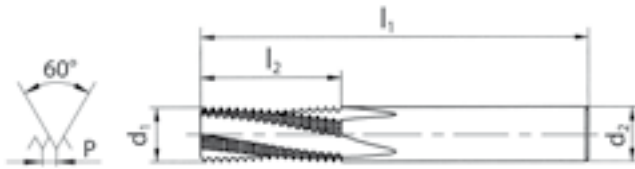

Ø" D ₁ UNC	P TPI	d ₁ mm	l ₁ mm	l ₂ mm	d ₂ mm			ID	ID
1/4	20	4.80	54	14.6	6.0	3	5.10	155407	155408
5/16	18	5.95	54	17.6	6.0	3	6.50	116047	135231
3/8	16	7.10	64	21.5	8.0	4	8.00	135232	135233
7/16	14	7.95	64	24.5	8.0	4	9.30	116049	135234
1/2	13	9.95	72	28.4	10.0	4	10.80	135235	135236

Ø" D ₁ UNC	P TPI	d ₁ mm	l ₁ mm	l ₂ mm	d ₂ mm			ID	ID
1/4	20	4.80	54	17.1	6.0	3	5.10	155409	155414
5/16	18	5.95	54	21.9	6.0	3	6.50	155410	155415
3/8	16	7.10	64	26.2	8.0	4	8.00	155411	155416
7/16	14	7.95	64	29.9	8.0	4	9.30	155412	155417
1/2	13	9.95	74	34.2	10.0	4	10.80	155413	155418

UNF ANSI B1.1

VHM
CAR



DIN 6535 HA

HB
HE

sur demande
auf Anfrage
on request
su richiesta
sobre pedido

GF

GF6110



GF6110VS



VS

GF6110

GF6110VS

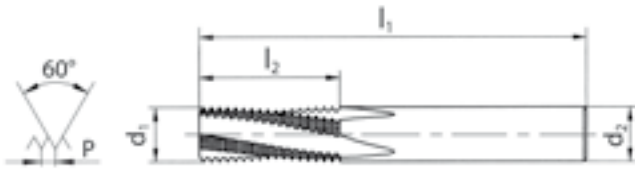

Ø" D ₁ UNF	P TPI	d ₁ mm	l ₁ mm	l ₂ mm	d ₂ mm		
10	32	3.60	48	8.3	6.0	3	4.05
12	28	4.10	48	9.5	6.0	3	4.60
1/4	28	4.80	54	11.3	6.0	3	5.50

ID

ID

128659

135237

135238

135239

135240

135176

GF-GFH-GFS

UNF ANSI B1.1

VHM
CAR



DIN 6535 HA

HB
HE

sur demande
auf Anfrage
on request
su richiesta
sobre pedido

GF

GF6165



GF6165VS



GF6166



GF6166VS



GF6165

GF6165VS

GF6166

GF6166VS

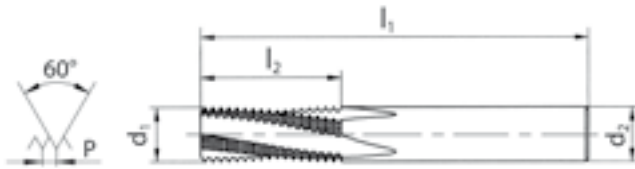

Ø" D ₁ UNF	P TPI	d ₁ mm	l ₁ mm	l ₂ mm	d ₂ mm			ID	ID
1/4	28	4.80	54	14.1	6.0	3	5.50	155419	155420
5/16	24	5.95	54	17.5	6.0	3	6.90	135242	135243
3/8	24	7.10	64	20.6	8.0	4	8.50	135182	135245
7/16	20	7.95	64	24.8	8.0	4	9.80	135246	135247
1/2	20	9.95	72	27.3	10.0	4	11.40	135183	135249

Ø" D ₁ UNF	P TPI	d ₁ mm	l ₁ mm	l ₂ mm	d ₂ mm			ID	ID
1/4	28	4.80	54	16.8	6.0	3	5.50	155421	155426
5/16	24	5.95	54	20.6	6.0	3	6.90	155422	155427
3/8	24	7.10	64	24.9	8.0	4	8.50	155423	155428
7/16	20	7.95	64	28.6	8.0	4	9.80	155424	155429
1/2	20	9.95	74	33.7	10.0	4	11.40	155425	155430

G DIN ISO 228 (BSP)

VHM
CAR



DIN 6535 HA

HB
HE

sur demande
auf Anfrage
on request
su richiesta
sobre pedido

GF

GF6165



GF6165VS



GF6166



GF6166VS



GF6165

GF6165VS

GF6166

GF6166VS

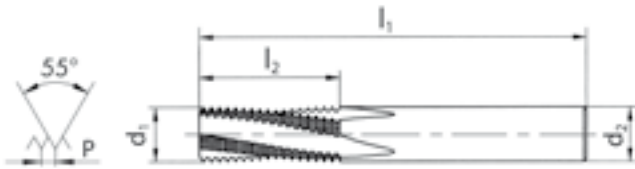
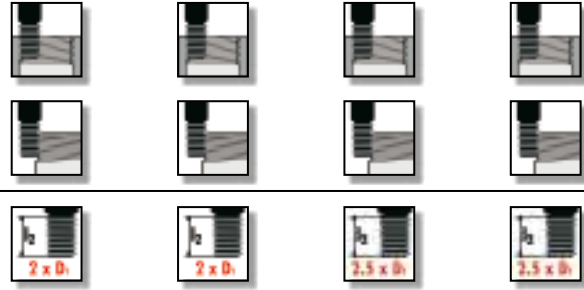

$\varnothing'' D_1$ G	P TPI	d_1 mm	l_1 mm	l_2 mm	d_2 mm		
1/8	28	7.95	64	21.3	8.0	4	8.75
1/4	19	9.95	72	28.7	10.0	4	11.60
3/8	19	13.60	80	35.4	14.0	4	15.20

ID

ID

119347

116409

119292

116410

119678

116411

$\varnothing'' D_1$ G	P TPI	d_1 mm	l_1 mm	l_2 mm	d_2 mm		
1/8	28	7.95	64	24.9	8.0	4	8.75
1/4	19	9.95	74	34.1	10.0	4	11.60
3/8	19	13.60	90	43.4	14.0	4	15.20

ID

ID

155431

155434

155432

155435

155433

155436

GF-GFH-GFS

NPT, NPTF

ANSI B1.20.1
ANSI B1.20.3



sur demande
auf Anfrage
on request
su richiesta
sobre pedido

GF

GF6160



GF6160VS



GF6160

GF6160VS

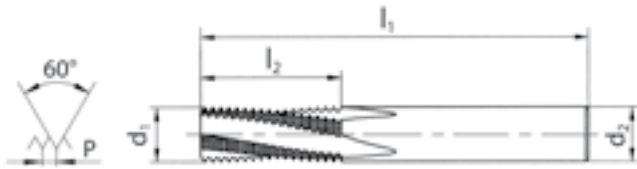

Ø" D ₁ NPT	P TPI	d ₁ mm	l ₁ mm	l ₂ mm	d ₂ mm	♣
1/8	27	7.30	64	9.9	8.0	4
1/4	18	9.95	72	14.8	12.0	4
3/8	18	12.50	80	14.8	14.0	4
1/2	14	14.70	90	19.1	16.0	4

ID ID

116371	116435
135250	135251
135252	135253
155437	155438

Ø" D ₁ NPTF	P TPI	d ₁ mm	l ₁ mm	l ₂ mm	d ₂ mm	♣
1/8	27	7.30	64	9.9	8.0	4
1/4	18	9.95	72	14.8	12.0	4
3/8	18	12.50	80	14.8	14.0	4
1/2	14	14.70	90	19.1	16.0	4

ID ID

* 135254	
* 135256	* 135257
* 135258	* 135259
* 155439	* 155440

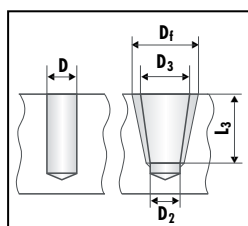

Ø D ₁	Vorbereitung Core hole			
	D	D ₂	NPT NPTF D ₃ (+0.05)	
1/8	8.5	8.3	8.74	8.76
1/4	11.0	10.8	11.36	11.40
3/8	14.5	14.2	14.80	14.84
1/2	17.9	17.5	18.32	18.33

Fräsen Milling	
D _f	L ₃
9.81	6.92
12.99	10.02
16.41	10.33
20.37	13.57

GFS

GFS6610



GFS6610VS

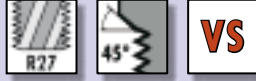

GFS6660



GFS6660VS

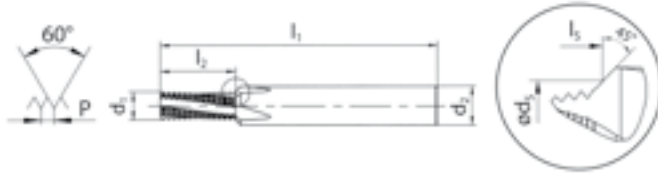

GFS6610



GFS6610VS



GFS6660



GFS6660VS



Ø D ₁ M	P mm	d ₁ mm	l ₁ mm	l ₂ mm	l ₃ mm	d _s mm	d ₂ mm		
2	0.40	1.50	48	3.4	3.7	2.1	6	2	1.60
2.5	0.45	1.90	48	4.3	4.7	2.6	6	3	2.05
3	0.50	2.30	48	5.3	5.6	3.1	6	3	2.50
3.5	0.60	2.70	48	5.7	6.2	3.6	6	3	2.90
4	0.70	3.00	48	7.3	7.9	4.1	6	3	3.30
5	0.80	3.80	54	9.2	9.9	5.1	6	3	4.20
6	1.00	4.50	62	10.5	11.3	6.2	8	3	5.00
8	1.25	5.95	74	13.1	14.3	8.2	10	3	6.80
10	1.50	7.95	80	17.3	18.4	10.3	12	4	8.50
12	1.75	9.95	90	20.1	21.3	12.3	14	4	10.20
14	2.00	10.80	102	25.0	26.8	14.4	16	4	12.00
16	2.00	12.80	102	27.0	28.8	16.4	18	4	14.00
18	2.50	13.95	125	33.8	36.0	18.5	25	4	15.50
20				37.0	20.5				17.50

ID

ID

ID

ID

* 135331

* 135332

* 155441

* 155443

135333

135334

* 155442

* 155444

135335

135336

135337

135338

135339

116175

135340

116172

135341

116173

135342

116174

* 135343

* 135344

135345

135346

* 135347

* 135348

GFS

GFS6615



GFS6615VS



GFS6665



GFS6665VS

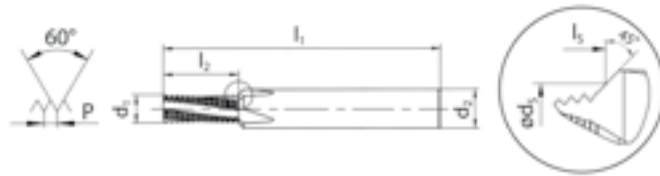

GFS6615

GFS6615VS

GFS6665

GFS6665VS



$\varnothing D_1$ M	P mm	d_1 mm	l_1 mm	l_2 mm	l_3 mm	d_5 mm	d_2 mm			ID	ID	ID	ID
2	0.40	1.50	48	4.6	4.9	2.1	6	2	1.60	135349	135350		
2.5	0.45	1.90	48	5.6	6.0	2.6	6	3	2.05	155445	155447		
3	0.50	2.30	48	6.8	7.1	3.1	6	3	2.50	125661	135351		
3.5	0.60	2.70	48	7.5	8.0	3.6	6	3	2.90	* 155446	* 147108		
4	0.70	3.00	48	8.8	9.3	4.1	6	3	3.30	125946	135352		
5	0.80	3.80	54	10.8	11.5	5.1	6	3	4.20	126160	116178		
6	1.00	4.50	62	13.5	14.3	6.2	8	3	5.00	126352	135353	155524	155525
8	1.25	5.95	74	18.1	19.3	8.2	10	3	6.80			126587	116343
10	1.50	7.95	80	21.8	22.9	10.3	12	4	8.50			124837	135354
12	1.75	9.95	90	25.4	26.6	12.3	14	4	10.20			124973	135355
14	2.00	10.80	102	31.0	32.8	14.4	16	4	12.00			* 125067	* 135356
16	2.00	12.80	102	35.0	36.8	16.4	18	4	14.00			125116	135357
18	2.50	13.95	125	41.3	43.5	18.5	25	4	15.50			* 125231	* 135358
20					44.5	20.5			17.50				

GFS

GFS6616



GFS6616VS



GFS6666



GFS6666VS

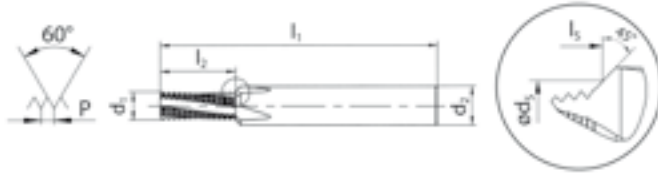

GFS6616

GFS6616VS

GFS6666

GFS6666VS



∅ D ₁ M	P mm	d ₁ mm	l ₁ mm	l ₂ mm	l ₃ mm	d ₃ mm	d ₂ mm		
3	0.50	2.30	48	8.3	8.7	3.1	6	3	2.50
4	0.70	3.00	48	10.9	11.5	4.1	6	3	3.30
5	0.80	3.80	54	13.2	13.9	5.1	6	3	4.20
6	1.00	4.50	62	16.5	17.4	6.2	8	3	5.00
8	1.25	5.95	74	21.9	23.0	8.2	10	3	6.80
10	1.50	7.95	80	26.3	27.5	10.3	12	4	8.50
12	1.75	9.95	90	32.4	33.6	12.3	14	4	10.20
14	2.00	10.80	102	37.0	38.8	14.4	16	4	12.00
16	2.00	12.80	102	43.0	44.8	16.4	18	4	14.00
18	2.50	13.95	125	53.8	56.1	18.5	25	4	15.50
20					57.1	20.5			17.50

ID

ID

ID

ID

155448

155452

155449

155453

155450

155454

155451

155455

155456

155463

155457

155464

155458

155465

155459

155466

* 155460

* 155467

155461

155468

* 155462

* 155469

GFS

GFS6610



GFS6610VS



GFS6660



GFS6660VS

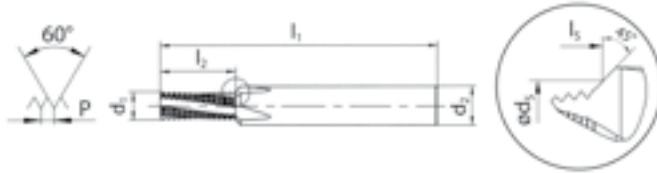

GFS6610



GFS6610VS



GFS6660



GFS6660VS



∅ D ₁ MF	P mm	d ₁ mm	l ₁ mm	l ₂ mm	l ₃ mm	d _s mm	d ₂ mm			ID	ID	ID	ID
4	0.50	3.00	48	7.3	7.8	4.1	6	3	3.50	135359	135360		
5	0.50	3.80	54	8.8	9.4	5.1	6	3	4.50	135361	135362		
6	0.50	4.50	62	9.8	10.6	6.2	8	3	5.50	135363	135364		
6	0.75	4.50	62	10.1	11.0	6.2	8	3	5.25	135365	135366		
8	0.50	5.95	74	12.8	13.9	8.2	10	3	7.50			135367	135368
8	0.75	5.95	74	13.1	14.3	8.2	10	3	7.25			135369	135370
8	1.00	5.95	74	13.5	14.6	8.2	10	3	7.00			135371	135372
10	1.00	7.95	80	16.5	17.7	10.3	12	4	9.00			135373	135374
10	1.25	7.95	80	16.9	18.1	10.3	12	4	8.80			* 135375	* 135376
12	1.00	9.95	90	19.5	20.7	12.3	14	4	11.00			135377	135378
12	1.50	9.95	90	20.3	21.4	12.3	14	4	10.50			135379	135380
14	1.50	10.80	102	23.3	25.0	14.4	16	4	12.50			135381	135382
16	1.50	12.80	102	26.3	28.1	16.4	18	4	14.50			135383	135384

GFS

GFS6615



GFS6615VS



GFS6665



GFS6665VS

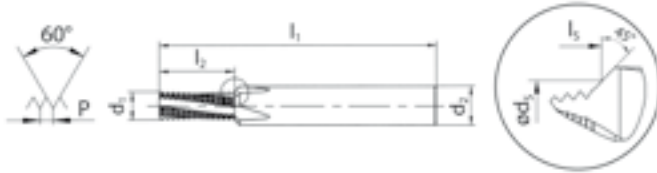

GFS6615



GFS6615VS



GFS6665



GFS6665VS



∅ D ₁ MF	P mm	d ₁ mm	l ₁ mm	l ₂ mm	l ₃ mm	d _s mm	d ₂ mm		
4	0.50	3.00	48	8.8	9.3	4.1	6	3	3.50
5	0.50	3.80	54	10.8	11.4	5.1	6	3	4.50
6	0.50	4.50	62	12.8	13.6	6.2	8	3	5.50
6	0.75	4.50	62	13.1	14.0	6.2	8	3	5.25
8	0.50	5.95	74	17.8	18.9	8.2	10	3	7.50
8	0.75	5.95	74	16.9	18.0	8.2	10	3	7.25
8	1.00	5.95	74	17.5	18.6	8.2	10	3	7.00
10	1.00	7.95	80	21.5	22.7	10.3	12	4	9.00
10	1.25	7.95	80	21.9	23.0	10.3	12	4	8.80
12	1.00	9.95	90	25.5	26.7	12.3	14	4	11.00
12	1.50	9.95	90	26.3	27.4	12.3	14	4	10.50
14	1.50	10.80	102	30.8	32.5	14.4	16	4	12.50
16	1.50	12.80	102	33.8	35.6	16.4	18	4	14.50

ID

ID

ID

ID

135385

135386

135387

135388

135389

135390

135391

135392

135393

135394

135395

135396

135397

135398

135399

135400

135401

135402

135403

135404

135405

135406

135407

135408

135409

135410

GFS

GFS6610



GFS6610VS



GFS6660



GFS6660VS

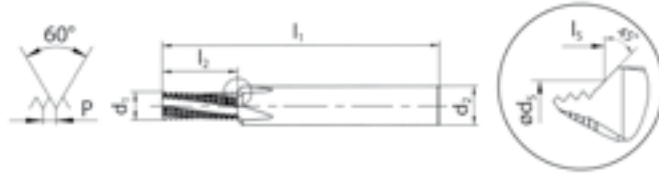

GFS6610

GFS6610VS

GFS6660

GFS6660VS



Ø" D ₁ UNC	P TPI	d ₁ mm	l ₁ mm	l ₂ mm	l ₃ mm	d _s mm	d ₂ mm		
10	24	3.60	54	10.1	10.7	4.9	6	3	3.80
12	24	4.10	54	10.1	10.8	5.6	6	3	4.40
1/4	20	4.80	62	12.1	12.9	6.5	8	3	5.10
5/16	18	5.95	74	14.8	15.9	8.1	10	3	6.50
3/8	16	7.10	80	16.7	18.0	9.8	12	4	8.00
7/16	14	7.95	80	19.0	20.8	11.4	12	4	9.30
1/2	13	9.95	90	22.5	24.0	13.0	14	4	10.80
9/16	12	10.80	102	24.4	26.3	14.6	16	4	12.20
5/8	11	11.90	102	26.5	28.8	16.3	18	4	13.60

ID

ID

ID

ID

* 135420

* 135421

* 135422

* 135423

* 135424

* 135425

* 155470

* 155473

* 135426

* 135427

* 155471

* 155474

* 135428

* 135429

* 155472

* 155475

* 135430

* 135431

* 135432

* 135433

* 135434

* 135435

* 135436

* 135437

GFS

GFS6615



GFS6615VS



GFS6665



GFS6665VS

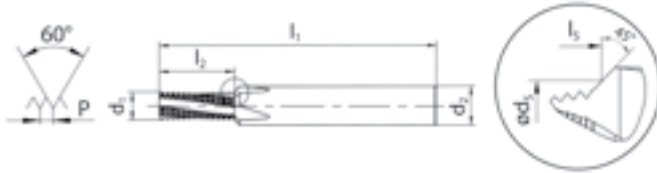

GFS6615

GFS6615VS

GFS6665

GFS6665VS



∅" D ₁ UNC	P TPI	d ₁ mm	l ₁ mm	l ₂ mm	l ₃ mm	d _s mm	d ₂ mm	3	4
--------------------------	----------	----------------------	----------------------	----------------------	----------------------	----------------------	----------------------	---	---

10	24	3.60	54	12.2	12.8	4.9	6	3	3.80
12	24	4.10	54	13.2	14.0	5.6	6	3	4.40
1/4	20	4.80	62	14.6	15.5	6.5	8	3	5.10
5/16	18	5.95	74	17.6	18.7	8.1	10	3	6.50
3/8	16	7.10	80	21.5	22.8	9.8	12	4	8.00
7/16	14	7.95	80	24.5	26.2	11.4	12	4	9.30
1/2	13	9.95	90	28.4	29.9	13.0	14	4	10.80
9/16	12	10.80	102	32.8	34.7	14.6	16	4	12.20
5/8	11	11.90	102	35.8	38.0	16.3	18	4	13.60

ID

ID

ID

ID

* 135438

* 135439

* 135440

* 135441

* 135442

* 135443

* 155476

* 155479

* 135444

* 135445

* 155477

* 155480

* 135446

* 135447

* 155478

* 155481

* 135448

* 135449

* 135450

* 135451

* 135452

* 135453

* 135454

* 135455

GFS

GFS

GFS6610



GFS6610VS



GFS6660



GFS6660VS

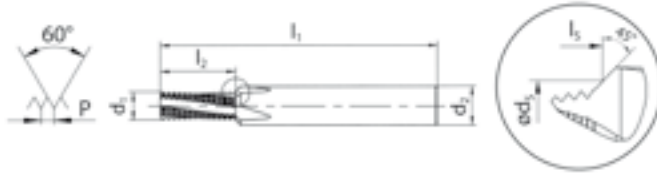

GFS6610

GFS6610VS

GFS6660

GFS6660VS



Ø" D ₁ UNF	P TPI	d ₁ mm	l ₁ mm	l ₂ mm	l ₃ mm	d _s mm	d ₂ mm		
10	32	3.60	54	8.3	9.0	4.9	6	3	4.05
12	28	4.10	54	9.5	10.3	5.6	6	3	4.60
1/4	28	4.80	62	11.3	12.2	6.5	8	3	5.50
5/16	24	5.95	74	13.2	14.3	8.1	10	3	6.90
3/8	24	7.10	80	16.4	17.3	9.8	12	4	8.50
7/16	20	7.95	80	18.4	20.1	11.4	12	4	9.80
1/2	20	9.95	90	21.0	22.5	13.0	14	4	11.40
9/16	18	11.60	102	23.3	24.8	14.6	16	4	12.90
5/8	18	11.90	102	26.1	28.3	16.3	18	4	14.50

ID

ID

ID

ID

* 135456

* 135457

* 135458

* 135459

* 135460

* 135461

* 155482

* 155485

* 135462

* 135463

* 155483

* 155486

* 135464

* 135465

* 155484

* 155487

* 135466

* 135467

* 135468

* 135469

* 135470

* 135471

* 135472

* 135473

GFS

GFS6615



GFS6615VS



GFS6665



GFS6665VS

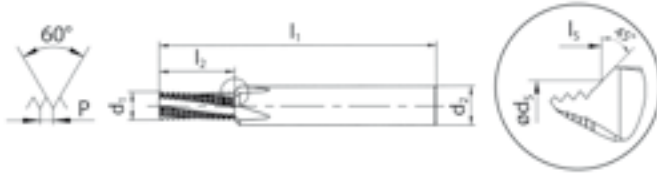

GFS6615

GFS6615VS

GFS6665

GFS6665VS



∅" D ₁	P	d ₁	l ₁	l ₂	l ₃	d _s	d ₂		
UNF	TPI	mm	mm	mm	mm	mm	mm		

10	32	3.60	54	11.5	12.2	4.9	6	3	4.05
12	28	4.10	54	12.3	13.0	5.6	6	3	4.60
1/4	28	4.80	62	14.1	14.9	6.5	8	3	5.50
5/16	24	5.95	74	17.5	18.6	8.1	10	3	6.90
3/8	24	7.10	80	20.6	21.5	9.8	12	4	8.50
7/16	20	7.95	80	24.8	26.5	11.4	12	4	9.80
1/2	20	9.95	90	27.3	28.8	13.0	14	4	11.40
9/16	18	11.60	102	30.4	31.9	14.6	16	4	12.90
5/8	18	11.90	102	34.6	36.8	16.3	18	4	14.50

ID

ID

ID

ID

128660

135474

* 135475

* 135476

128578

135477

155488

155491

135478

135479

155489

155492

135480

135481

155490

155493

* 135482

* 135483

* 135484

* 135485

* 135486

* 135487

* 135488

* 135489

GFS

G DIN ISO 228 (BSP)

VHM
CAR

DIN 6535 HA

HB
HE

sur demande
auf Anfrage
on request
su richiesta
sobre pedido

GFS

GFS6660



GFS6660VS



GFS6665



GFS6665VS

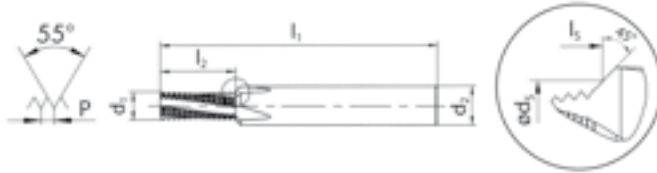

GFS6660



GFS6660VS



GFS6665



GFS6665VS



$\varnothing'' D_1$ G	P TPI	d_1 mm	l_1 mm	l_2 mm	l_3 mm	d_5 mm	d_2 mm		
1/8	28	7.95	80	15.9	16.9	10.0	12	4	8.75
1/4	19	9.95	90	22.1	23.8	13.5	14	4	11.60
3/8	19	12.80	102	27.4	29.5	17.1	18	4	15.20

ID

ID

* 135411

* 135412

* 135413

* 135414

* 135415

* 135416

$\varnothing'' D_1$ G	P TPI	d_1 mm	l_1 mm	l_2 mm	l_3 mm	d_5 mm	d_2 mm		
1/8	28	7.95	80	21.3	22.3	10.0	12	4	8.75
1/4	19	9.95	90	28.7	30.5	13.5	14	4	11.60
3/8	19	12.80	102	35.4	37.6	17.1	18	4	15.20

ID

ID

* 119349

* 135417

* 119298

* 135418

* 119680

* 135419

NPT, NPTF

ANSI B1.20.1
ANSI B1.20.3

VHM
CAR

DIN 6535 HA

HB
HE

sur demande
auf Anfrage
on request
su richiesta
sobre pedido

GFS

GFS6660



GFS6660VS



GFS6660

GFS6660VS

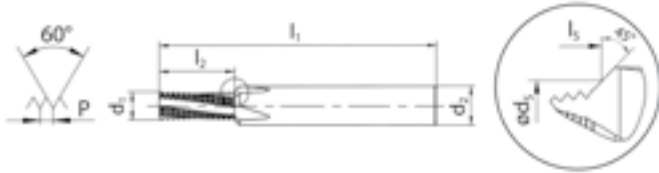

Ø" D ₁ NPT	P TPI	d ₁ mm	l ₁ mm	l ₂ mm	l ₃ mm	d ₂ mm	d ₃ mm	4
--------------------------	----------	----------------------	----------------------	----------------------	----------------------	----------------------	----------------------	---

1/8	27	7.30	70	9.9	11.2	10.6	12	4
1/4	18	9.95	80	14.8	16.4	14.0	16	4
3/8	18	12.50	80	14.8	16.9	17.6	18	4

ID

ID

* 126910	* 135490
* 126899	* 135491
* 126928	* 135492

Ø" D ₁ NPTF	P TPI	d ₁ mm	l ₁ mm	l ₂ mm	l ₃ mm	d ₂ mm	d ₃ mm	4
---------------------------	----------	----------------------	----------------------	----------------------	----------------------	----------------------	----------------------	---

1/8	27	7.30	70	9.9	11.2	10.6	12	4
1/4	18	9.95	80	14.8	16.4	14.0	16	4
3/8	18	12.50	80	14.8	16.9	17.6	18	4

ID

ID

* 135493	* 135494
* 135495	* 135496
* 135497	* 135498

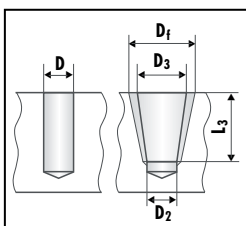

Ø D ₁	Vorbereitung Core hole			
	D	D ₂	NPT NPTF D ₃ (+0.05)	
1/8	8.5	8.3	8.74	8.76
1/4	11.0	10.8	11.36	11.40
3/8	14.5	14.2	14.80	14.84

Fräsen Milling	
D _f	L ₃
9.81	6.92
12.99	10.02
16.41	10.33

GFM

GFM6260



GFM6260VS



GFM6260

GFM6260VS

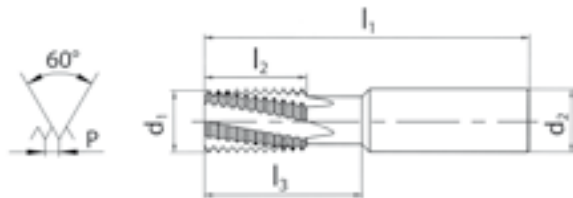

d ₁ mm	P mm	∅ D ₁ ≥ M, MF	l ₁ mm	l ₂ mm	l ₃ mm	d ₂ mm	✚	ID	ID
8	0.50	10	64	16.0	16	8.0	4	116450	135260
8	0.75	10	64	15.8	16	8.0	4	116340	135261
10	0.75	14	70	15.8	26	10.0	4	116128	135262
10	1.00	14	70	16.0	26	10.0	4	118657	135263
10	1.25	14	70	16.3	26	10.0	4	118659	135264
10	1.50	14	70	16.5	26	10.0	4	118661	135265
12	0.50	18	80	20.0	32	12.0	4	116129	135214
12	0.75	18	80	20.3	32	12.0	4	155526	155527
12	1.00	18	80	20.0	32	12.0	4	118664	135007
12	1.50	18	80	21.0	32	12.0	4	118669	135181
12	2.00	18	80	20.0	32	12.0	4	118673	135269
16	1.00	24	90	25.0	42	16.0	4	118680	135270
16	1.50	24	90	25.5	42	16.0	4	118682	116017
16	2.00	24	90	26.0	42	16.0	4	118684	135271
16	2.50	24	90	25.0	42	16.0	4	118689	135272
16	3.00	24	90	27.0	42	16.0	4	158760	150564
20	1.00	30	105	33.0	52	20.0	5	135273	135274
20	1.50	30	105	33.0	52	20.0	5	118694	135275
20	2.00	30	105	34.0	52	20.0	5	116338	135276
20	2.50	30	105	32.5	52	20.0	5	* 135277	
20	3.00	30	105	33.0	52	20.0	5	118699	135279
20	3.50	30	105	38.5	52	20.0	5	144195	144065

GFM

GFM6260



GFM6260VS



GFM6260

GFM6260VS

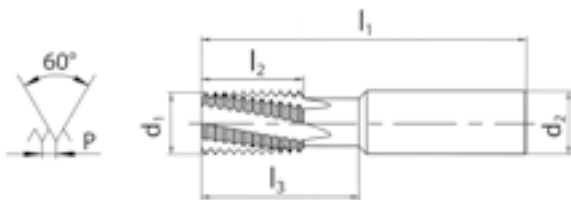

d ₁ mm	P TPI	Ø" D ₁ ≥ UN	l ₁ mm	l ₂ mm	l ₃ mm	d ₂ mm	✂	ID	ID
10	24	1/2	70	15.9	26	10	4	135288	135289
12	24	3/4	80	20.1	32	12	4	135290	135291
12	20	3/4	80	20.3	32	12	4	135292	135293
12	18	3/4	80	19.8	32	12	4	135294	135295
12	16	3/4	80	20.6	32	12	4	135296	135297
12	10	3/4	80	20.3	32	12	4	150963	155494
16	24	1	90	25.4	42	16	4	135298	135299
16	20	1	90	25.4	42	16	4	135300	135301
16	18	1	90	25.4	42	16	4	135302	135303
16	16	1	90	25.4	42	16	4	135304	135305
16	14	1	90	25.4	42	16	4	135306	135307
16	12	1	90	25.4	42	16	4	135308	135309
16	9	1	90	25.4	42	16	4	150964	155495
16	8	1	90	25.4	42	16	4	150965	155496
20	24	1 1/4	105	32.8	52	20	5	* 135310	* 135311
20	20	1 1/4	105	33.0	52	20	5	* 135312	* 135313
20	18	1 1/4	105	32.5	52	20	5	135314	135315
20	16	1 1/4	105	33.4	52	20	5	118697	135316
20	14	1 1/4	105	32.7	52	20	5	135317	135318
20	12	1 1/4	105	31.8	52	20	5	135319	135320
20	8	1 1/4	105	31.8	52	20	5	135321	135322
20	7	1 1/4	105	32.7	52	20	5	150962	155497

GFM

GFM6260



GFM6260VS



GFM6260

GFM6260VS

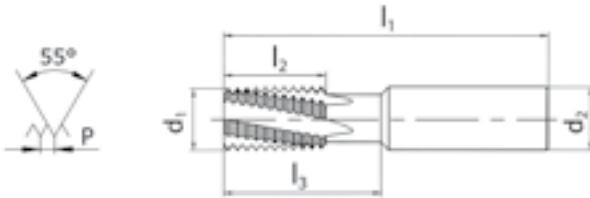

d ₁ mm	P TPI	Ø" D ₁ G	l ₁ mm	l ₂ mm	l ₃ mm	d ₂ mm	✂
10	19	1/4 - 3/8	70	16.0	26	10	4
16	14	1/2 - 7/8	90	25.4	42	16	4
20	11	≥ 1	105	32.3	52	20	5

ID

ID

118655

135280

118678

135281

118691

135282

NPT, NPTF

ANSI B1.20.1
ANSI B1.20.3

VHM
CAR



DIN 6535 HA

HB
HE

sur demande
auf Anfrage
on request
su richiesta
sobre pedido

GFM

GFM6260



GFM6260VS

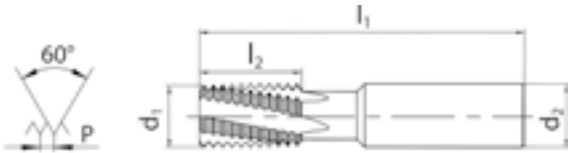

GFM6260

GFM6260VS



d ₁ mm	P TPI	Ø" D ₁ ≥ NPT	l ₁ mm	l ₂ mm	d ₂ mm	✿
14.5	14	1/2	90	19.1	16	4
18.5	11.5	1	90	23.2	20	5

ID

ID

135323

135324

135325

135326

d ₁ mm	P TPI	Ø" D ₁ ≥ NPTF	l ₁ mm	l ₂ mm	d ₂ mm	✿
14.5	14	1/2	90	19.1	16	4
18.5	11.5	1	90	23.2	20	5

ID

ID

* 135327

* 135328

* 135329

* 135330

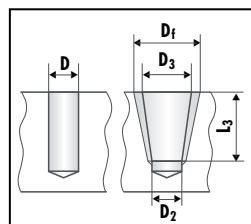

Ø D ₁	Vorbereitung Core hole			
	D	D ₂	NPT D ₃ (+0.05)	NPTF D ₃ (+0.05)
1/2	17.9	17.5	18.32	18.33
3/4	23.2	22.8	23.67	23.68
1	29.0	28.6	29.69	29.72
1 1/4	37.7	37.3	38.45	38.48
1 1/2	44.0	43.5	44.52	44.55
2	56.0	55.5	56.56	56.59

Fräsen
Milling

D _f	L ₃
20.37	13.57
25.69	14.05
32.18	16.79
40.90	17.30
49.67	17.30
58.99	17.70

GFM

BGF

BGF6760



BGF6760VS



BGF6760

BGF6760VS

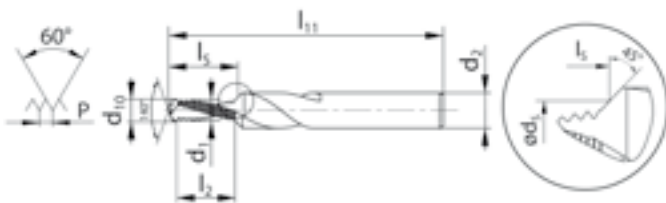

$\varnothing D_1$ M	P mm	d_1 mm	d_{10} mm	l_{11} mm	l_2 mm	l_3 mm	d_5 mm	d_2 mm		ID	ID
4	0.70	3.10	3.30	48	5.6	7.4	4.1	6	2	153400	153415
5	0.80	4.00	4.20	54	7.2	9.4	5.1	6	2	153401	153416
6	1.00	4.75	5.00	62	9.0	11.7	6.2	8	2	153402	153417
8	1.25	6.50	6.75	74	11.2	14.6	8.2	10	2	151911	153418
10	1.50	8.25	8.50	80	14.9	19.1	10.3	12	2	153403	151442
12	1.75	9.95	10.25	90	17.4	22.1	12.3	14	2	153404	153419
14	2.00	11.60	12.00	102	19.9	25.1	14.4	16	2	* 153405	* 153420
16	2.00	13.60	14.00	102	23.9	29.5	16.4	18	2	* 153406	* 153421

BGF

BGF6765



BGF6765VS



BGF6766



BGF6766VS

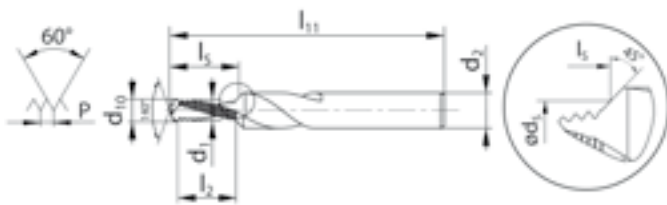

BGF6765

BGF6765VS

BGF6766

BGF6766VS



$\varnothing D_1$ M	P mm	d_1 mm	d_{10} mm	l_{11} mm	l_2 mm	l_3 mm	d_5 mm	d_2 mm	
4	0.70	3.10	3.30	48	7.7	9.5	4.1	6	2
5	0.80	4.00	4.20	54	9.6	11.8	5.1	6	2
6	1.00	4.75	5.00	62	12.0	14.7	6.2	8	2
8	1.25	6.50	6.75	74	15.0	18.4	8.2	10	2
10	1.50	8.25	8.50	80	19.4	23.6	10.3	12	2
12	1.75	9.95	10.25	90	22.7	27.3	12.3	14	2
14	2.00	11.60	12.00	102	27.9	33.1	14.4	16	2
16	2.00	13.60	14.00	102	31.9	37.5	16.4	18	2

ID

ID

153430	153442
151305	151306
150933	151776
153431	150588
153432	150589
153433	150927
* 153434	* 153443
* 153435	* 151324

$\varnothing D_1$ M	P mm	d_1 mm	d_{10} mm	l_{11} mm	l_2 mm	l_3 mm	d_5 mm	d_2 mm	
6	1.00	4.75	5.00	62	15.0	17.7	6.2	8	2
8	1.25	6.50	6.75	74	20.0	23.4	8.2	10	2
10	1.50	8.25	8.50	80	23.9	28.1	10.3	12	2
12	1.75	9.95	10.25	90	29.7	34.3	12.3	14	2
14	2.00	11.60	12.00	102	35.9	41.1	14.4	16	2
16	2.00	13.60	14.00	102	39.9	45.5	16.4	18	2

ID

ID

153451	153467
153452	153468
153453	153469
153454	153470
* 153455	* 153471
* 153456	* 153472

BGF

BGF6865



BGF6865VS



BGF6866



BGF6866VS

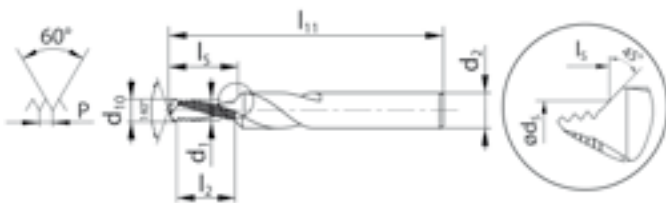

BGF6865

BGF6865VS

BGF6866

BGF6866VS



$\varnothing D_1$ M	P mm	d_1 mm	d_{10} mm	l_{11} mm	l_2 mm	l_3 mm	d_5 mm	d_2 mm	
------------------------	---------	-------------	----------------	----------------	-------------	-------------	-------------	-------------	--

6	1.00	4.75	5.00	62	12.0	14.7	6.2	8	3
8	1.25	6.50	6.75	74	14.9	18.4	8.2	10	3
10	1.50	8.25	8.50	80	19.4	23.6	10.3	12	3
12	1.75	9.95	10.25	90	22.7	27.3	12.3	14	3
14	2.00	11.60	12.00	102	27.9	33.1	14.4	16	3
16	2.00	13.60	14.00	102	31.9	37.5	16.4	18	3

ID

ID

* 153577

* 153589

* 153578

* 153590

* 153579

* 153591

* 153580

* 153592

* 153581

* 153593

* 153582

* 153594

$\varnothing D_1$ M	P mm	d_1 mm	d_{10} mm	l_{11} mm	l_2 mm	l_3 mm	d_5 mm	d_2 mm	
------------------------	---------	-------------	----------------	----------------	-------------	-------------	-------------	-------------	--

6	1.00	4.75	5.00	62	15.0	17.7	6.2	8	3
8	1.25	6.50	6.75	74	20.0	23.4	8.2	10	3
10	1.50	8.25	8.50	80	23.9	28.1	10.3	12	3
12	1.75	9.95	10.25	90	29.7	34.3	12.3	14	3
14	2.00	11.60	12.00	102	35.9	41.1	14.4	16	3
16	2.00	13.60	14.00	102	39.9	45.5	16.4	18	3

ID

ID

* 153601

* 153613

* 153602

* 153614

* 153603

* 153615

* 153604

* 153616

* 153605

* 153617

* 153606

* 153618

BGF

BGF6760



BGF6760VS



BGF6765



BGF6765VS

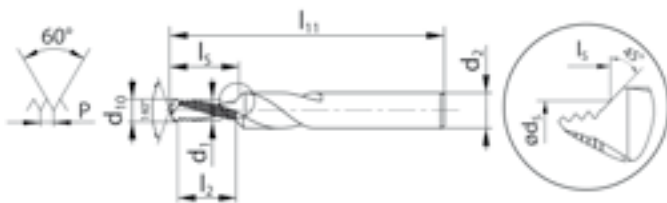

BGF6760

BGF6760VS

BGF6765

BGF6765VS



∅ D ₁ MF	P mm	d ₁ mm	d ₁₀ mm	l ₁₁ mm	l ₂ mm	l _s mm	d _s mm	d ₂ mm	
6	0.75	5.00	5.25	62	9.0	11.4	6.2	8	2
8	1.00	6.75	7.00	74	12.0	15.0	8.2	10	2
10	1.00	8.75	9.00	80	15.0	18.5	10.3	12	2
12	1.00	10.70	11.00	90	18.0	21.9	12.3	14	2
12	1.50	10.20	10.50	90	17.9	22.5	12.3	14	2
14	1.50	12.10	12.50	102	20.9	26.0	14.4	16	2
16	1.50	14.10	14.50	102	23.9	29.4	16.4	18	2

ID	ID
* 153759	* 153780
* 153761	* 153782
* 153762	* 153783
* 153764	* 153785
* 153765	* 153786
* 153766	* 153787
* 153767	* 153788





































∅ D ₁ MF	P mm	d ₁ mm	d ₁₀ mm	l ₁₁ mm	l ₂ mm	l _s mm	d _s mm	d ₂ mm	
6	0.75	5.00	5.25	62	9.0	11.4	6.2	8	2
8	1.00	6.75	7.00	74	12.0	15.0	8.2	10	2
10	1.00	8.75	9.00	80	15.0	18.5	10.3	12	2
12	1.00	10.70	11.00	90	18.0	21.9	12.3	14	2
12	1.50	10.20	10.50	90	17.9	22.5	12.3	14	2
14	1.50	12.10	12.50	102	20.9	26.0	14.4	16	2
16	1.50	14.10	14.50	102	23.9	29.4	16.4	18	2







ID	ID
* 153802	* 153824
* 153804	* 153826
* 153805	* 153827
* 153807	* 153829
* 153808	* 153830
* 153809	* 153831
* 153810	* 153832

BGF

















Inhaltsverzeichnis - Runde-, Automaten-, Sechskant- und Glocken-Schneideisen

Directory - Round dies, button dies for Swiss automatics, hexagon die nuts and bell form dies

		N		MS	Z		N	Z
Merkmale Characteristics		  	   	   	    	    	   	    
								
		N5110	N5120	MS5120	Z5120	Z5120LL	N5220	Z5220
M 6g	DIN 13	246	246		247	247	260	260
M 6e	DIN 13		246				260	
M 6g LH	DIN 13		246					
MF 6g	DIN 13	248	248-250		248-249		261	
MF 6e	DIN 13		248-249					
MF 6g LH	DIN 13		248-250					
UNC	ANSI B1.1	251	251					
UNF	ANSI B1.1	252	252					
UNEF	ANSI B1.1		253					
UN	ANSI B1.1		253					
UNS	ANSI B1.1		253					
G (BSP)	DIN ISO 228		254	255	255			
G (BSP) LH	DIN ISO 228		254					
G (BSP) -0.1 mm	DIN ISO 228			255				
R (BSPT)	DIN EN 10226		256					
NPT	ANSI B1.20.1		257					
NPTF	ANSI B1.20.3		257					
PG	DIN 40430		258					
TR	DIN 103		258					
W (BSW)	BS 84		259					
W (BSW) LH	BS 84		259					

N	
 	  
	
N5310	N5420
262	263
262	
263	
263	

Piktogramme - Pictographs

	HSS HSS
	HSSE HSSE
	1.25 Gewindegänge 1.25 chamfered threads
	1.75 Gewindegänge 1.75 chamfered threads
	2 Gewindegänge 2 chamfered threads
	Schälanschnitt ab Ø 3 mm Peeling cut from Ø 3 mm
	Schälanschnitt, beidseitig, ab Ø 3 mm Peeling cut on both sides from Ø 3 mm
	Anzahl Spannuten Number of flutes
	Vordrehdurchmesser Turned diameters
	Nitriert ($d_1 \geq 3 \text{ mm}$, $P \geq 0.5 \text{ mm}$) Nitrided ($d_1 \geq 3 \text{ mm}$, $P \geq 0.5 \text{ mm}$)
	Schneideisen mit 2 Aufschraublöchern Die with 2 securing holes
	Toleranz 6g Tolerance 6g
	Toleranz 6e Tolerance 6e
	Toleranz "Medium Class" Tolerance "Medium Class"
	Toleranz A Tolerance A
	Konisches Gewinde 1:16 (NPT - NPTF - R) Tapered thread 1:16 (NPT - NPTF - R)
	Linksgewinde Left hand thread

N5110									N5110	N5120	N5120 LH	N5120
N5120												
N5120 LH												
N5120												
$\varnothing d_1$	P	d_2	l_1	\oplus	\oplus	$\leftarrow 6g \leftarrow$	$\leftarrow 6e \leftarrow$	ID	ID	ID	ID	$6g$ - mm
M	mm	mm	mm	6g	LH / 6e							
1	0.25	16.0	5.0	3		0.97		103851				
1.1	0.25	16.0	5.0	3		1.07		124659				
1.2	0.25	16.0	5.0	3		1.17		103852				
1.4	0.30	16.0	5.0	3		1.36		103853				
1.6	0.35	16.0	5.0	3		1.54		103855				
1.7	0.35	16.0	5.0	3		1.64		103856				
1.8	0.35	16.0	5.0	3		1.74		103857				
2	0.40	16.0	5.0	3		1.93	1.90	103864				
2.2	0.45	16.0	5.0	3		2.13		103867				
2.3	0.40	16.0	5.0	3		2.23		103869				
2.5	0.45	16.0	5.0	3		2.43	2.40	103872				
2.6	0.45	16.0	5.0	3		2.53		103876				
3	0.50	20.0	5.0	3	4	2.92	2.90	103879	104067	104068	104066	0.030
3.5	0.60	20.0	5.0	3	4	3.41	3.38	103880	104071	104072	* 104070	0.030
4	0.70	20.0	5.0	3	4	3.91	3.87	103881	104114	104115	104113	0.035
4.5	0.75	20.0	7.0	4		4.40		103882	104117			
5	0.80	20.0	7.0	4	4	4.90	4.87	103883	104146	104147	104145	0.035
5.5	0.90	20.0	7.0	4		5.40		103884				
6	1.00	20.0	7.0	4	4	5.88	5.85	103885	104165	104166	104164	0.035
7	1.00	25.0	9.0	4	4	6.88		103886	104174	104175		
8	1.25	25.0	9.0	4	4	7.87	7.83	103887	104186	104187	104185	0.035
9	1.25	25.0	9.0	4		8.87		103888	104191			
10	1.50	30.0	11.0	4	4	9.85	9.82	103858	103953	103954	103952	0.035
12	1.75	38.0	14.0	4	4	11.83	11.80	103859	103973	103974	103972	0.035
14	2.00	38.0	14.0	4	4	13.82		103860	103989	103990		
16	2.00	45.0	18.0	4	4	15.82	15.79		104003	104004	* 104002	0.035
18	2.50	45.0	18.0	5		17.79		* 103862	104015			
20	2.50	45.0	18.0	5	5	19.79		103878	104028	104029		
22	2.50	55.0	22.0	5		21.79			104035			
24	3.00	55.0	22.0	5	5	23.76			104043	104044		
27	3.00	65.0	25.0	5		26.76			104058			
30	3.50	65.0	25.0	5	5	29.73			104079	104080		
33	3.50	65.0	25.0	6		32.73			104089			
36	4.00	65.0	25.0	7		35.70			104100			

≤ M1.4 6h

Z5120		Z5120 LL		Z5120			Z5120 LL		
$\varnothing d_1$ M	P mm	d_2 mm	l_1 mm				ID	ID	
2	0.40	16.0	3.5	4	4	1.93	125269	105115	
2.5	0.45	16.0	5.0	4	4	2.43	104779	105116	
2.6	0.45	16.0	5.0	4		2.53	104780		
3	0.50	20.0	5.0	4	5	2.92	104788	105117	
3.5	0.60	20.0	5.0	4		3.41	104789		
4	0.70	20.0	5.0	4	5	3.91	104790	105118	
5	0.80	20.0	7.0	4	5	4.90	104792	105119	
6	1.00	20.0	7.0	4	5	5.88	104795	105120	
7	1.00	25.0	9.0	4		6.88	111424		
8	1.25	25.0	9.0	5	6	7.87	104798	105121	
10	1.50	30.0	11.0	5	6	9.85	104767	105122	
12	1.75	38.0	14.0	5	6	11.83	104770	105123	
14	2.00	38.0	14.0	5		13.82	104773		
16	2.00	45.0	18.0	5		15.82	104776		
18	2.50	45.0	18.0	5		17.79	104778		
20	2.50	45.0	18.0	5		19.79	104783		
24	3.00	55.0	22.0	6		23.76	104787		



















								N5120	N5120 LH	N5120	Z5120	
								6g	6g	6e	6g	
∅ d ₁ MF	P mm	d ₂ mm	l ₁ mm	N	Z	→ 6g ←	→ 6e ←	ID	ID	ID	6g - mm	ID
* 2	0.25	16.0	5.0	4		1.93		103863				
* 2.5	0.35	16.0	5.0	4		2.44		103871				
3	0.35	20.0	5.0	4		2.94		104064				
3.5	0.35	20.0	5.0	4		3.44		104069				
4	0.35	20.0	5.0	4		3.94		104108				
4	0.50	20.0	5.0	4		3.93		104110				
4.5	0.50	20.0	5.0	4		4.43		104116				
5	0.50	20.0	5.0	4	4	4.93	4.90	104141	104142	104140	0.030	104791
5	0.75	20.0	7.0	4		4.90		104143				
5.5	0.50	20.0	5.0	4		5.43		104148				
6	0.50	20.0	5.0	4		5.93		104159	104160			104793
6	0.75	20.0	7.0	4	4	5.90		104162	104163			104794
7	0.50	25.0	9.0	4	4	6.93		104169				
7	0.75	25.0	9.0	4		6.90	6.87	104171		* 104170	0.035	
8	0.50	25.0	9.0	5		7.93		104177				
8	0.75	25.0	9.0	4	4	7.90		104180				104796
8	1.00	25.0	9.0	4	4	7.88	7.85	104183	104184	104182	0.035	104797
9	0.50	25.0	9.0	5		8.93		104188				
9	0.75	25.0	9.0	5		8.90		104189				
9	1.00	25.0	9.0	5		8.88		104190				
10	0.50	30.0	11.0	5		9.93		103942				
10	0.75	30.0	11.0	5	5	9.90	9.87	103945		* 103944	0.035	104765
10	1.00	30.0	11.0	5	5	9.88	9.85	103948	103949	103947	0.035	104766
10	1.25	30.0	11.0	4		9.86		103950	103951			
11	0.75	30.0	11.0	5		10.90		103956				
11	1.00	30.0	11.0	5		10.88		103957				
11	1.25	30.0	11.0	5		10.87		103958				
12	0.50	38.0	10.0	5		11.93		103960				
12	0.75	38.0	10.0	5		11.90	11.87	103962		* 103961	0.035	
12	1.00	38.0	10.0	5	5	11.88	11.85	103965	103966	103964	0.035	104768
12	1.25	38.0	10.0	4		11.86		103967	103968			
12	1.50	38.0	10.0	4	5	11.85		103970	103971			104769
13	1.00	38.0	10.0	5		12.88		103976				



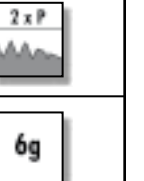

* N5110

P 0.25

6h

N5120		N5120 LH		N5120		Z5120		N5120	N5120 LH	N5120	Z5120	
												
												
$\varnothing d_1$ MF	P mm	d_2 mm	l_1 mm	N	Z	$\rightarrow 6g \leftarrow$	$\rightarrow 6e \leftarrow$	ID	ID	ID	$6g$ - mm	ID
14	0.50	38.0	10.0	5		13.93		103977				
14	0.75	38.0	10.0	5		13.90		103979				
14	1.00	38.0	10.0	5	5	13.88		103981	103982			104771
14	1.25	38.0	10.0	5		13.86		103983				
14	1.50	38.0	10.0	5	5	13.85		103986	103987			104772
15	1.00	38.0	10.0	5		14.88		103991				
15	1.50	38.0	10.0	5		14.85		103992				
16	1.00	45.0	14.0	5	5	15.88	15.85	103996	103997	* 103995	0.035	104774
16	1.25	45.0	14.0	5		15.87		103998				
16	1.50	45.0	14.0	5	5	15.85		104000	104001			104775
17	1.00	45.0	14.0	5		16.88		104005				
18	1.00	45.0	14.0	5		17.88		104008				
18	1.50	45.0	14.0	5	5	17.85		104011	104012			
18	2.00	45.0	14.0	5		17.82		104013				
19	1.00	45.0	14.0	6		18.88		104017				
20	1.00	45.0	14.0	6	6	19.88		104021	104022			104781
20	1.50	45.0	14.0	6	6	19.85		104024	104025			104782
20	2.00	45.0	14.0	6		19.82		104026	* 104027			
21	1.00	45.0	14.0	7		20.88		111386				
22	1.00	55.0	16.0	6		21.88		104030				
22	1.50	55.0	16.0	5	6	21.85		104032				
22	2.00	55.0	16.0	5		21.82		104034				
23	1.00	55.0	16.0	6		22.88		121704				
24	1.00	55.0	16.0	6		23.88		104037				
24	1.50	55.0	16.0	6	6	23.85		104039				
24	2.00	55.0	16.0	6		23.82		104041	104042			
25	1.00	55.0	16.0	6		24.88		104045				
25	1.50	55.0	16.0	6		24.85		104046				
26	1.00	55.0	16.0	7		25.88		104049				
26	1.50	55.0	16.0	6		25.85		104050				
26	2.00	55.0	16.0	6		25.82		104052				
27	1.00	65.0	18.0	6		26.88		104053				
27	1.50	65.0	18.0	6		26.85		104054	* 104055			
27	2.00	65.0	18.0	6		26.82		104056				



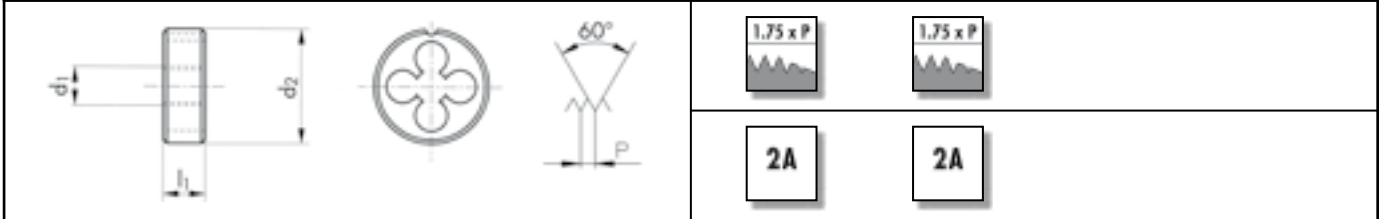

N5120		N5120 LH		N5120		N5120 LH	
$\varnothing d_1$ MF	P mm	d_2 mm	l_1 mm	\oplus	$\rightarrow 6g \leftarrow$	ID	ID
28	1.00	65.0	18.0	6	27.88	104060	
28	1.50	65.0	18.0	6	27.85	104061	
30	1.00	65.0	18.0	7	29.88	104073	
30	1.50	65.0	18.0	6	29.85	104074	
30	2.00	65.0	18.0	6	29.82	104076	
32	1.50	65.0	18.0	7	31.85	104082	* 104083
33	1.50	65.0	18.0	7	32.85	104085	
33	2.00	65.0	18.0	7	32.82	104086	
33	3.00	65.0	25.0	7	32.76	* 104088	
34	1.50	65.0	18.0	7	33.85	104091	
35	1.50	65.0	18.0	8	34.85	104092	* 104093
36	1.50	65.0	18.0	8	35.85	104095	* 104096
36	2.00	65.0	18.0	8	35.82	104097	
36	3.00	65.0	25.0	7	35.76	104099	
38	1.50	75.0	20.0	7	37.85	104101	
39	1.50	75.0	20.0	7	38.85	104104	
40	1.50	75.0	20.0	8	39.85	104118	* 104119
40	2.00	75.0	20.0	7	39.82	104120	
42	1.50	75.0	20.0	8	41.85	104122	
42	3.00	75.0	20.0	8	41.76	104125	
45	1.50	90.0	22.0	7	44.85	104127	
45	2.00	90.0	22.0	7	44.82	104129	
48	1.50	90.0	22.0	8	47.85	104133	* 104134
48	2.00	90.0	22.0	8	47.82	104135	
48	3.00	90.0	22.0	7	47.76	104137	
50	1.50	90.0	22.0	8	49.85	104150	
60	2.00	105.0	22.0	9	59.82	104168	

N5110 N5120	 	 	N5110	N5120		
						



Ø" d ₁ UNC	P TPI	d ₂ mm	l ₁ mm	⊕	⚙ →2A←	ID	ID
1	64	16.0	5.0	3	1.79	103893	
2	56	16.0	5.0	4	2.12	103894	
3	48	16.0	5.0	4	2.44	103895	
4	40	16.0	5.0	4	2.76	103896	
5	40	20.0	5.0	4	3.09		104263
6	32	20.0	7.0	4	3.41		104266
8	32	20.0	7.0	4	4.07		104269
10	24	20.0	7.0	4	4.71		104258
12	24	20.0	7.0	4	5.37		104259
1/4	20	20.0	7.0	4	6.22		104256
5/16	18	25.0	9.0	4	7.80		104264
3/8	16	30.0	11.0	4	9.37		104262
7/16	14	30.0	11.0	4	10.95		104267
1/2	13	38.0	14.0	4	12.52		111387
9/16	12	38.0	14.0	4	14.10		104270
5/8	11	45.0	18.0	4	15.68		104265
3/4	10	45.0	18.0	5	18.84		104261
7/8	9	55.0	22.0	5	22.00		104268
1	8	55.0	22.0	5	25.16		104257
1 1/4	7	65.0	25.0	6	31.49		104251
1 1/2	6	75.0	30.0	6	37.81		104250
2	4.5	90.0	36.0	7	50.45		* 104260



N5110							N5110	N5120		
N5120										
										
										
Ø" d ₁ UNF	P TPI	d ₂ mm	l ₁ mm	⊕	⊖	→2A←	ID	ID		
0	80	16.0	5.0	3		1.47	103897			
1	72	16.0	5.0	3		1.79	103898			
2	64	16.0	5.0	4		2.12	103899			
3	56	16.0	5.0	4		2.44	103900			
4	48	16.0	5.0	4		2.77	103901			
5	44	20.0	5.0	4		3.10		104299		
6	40	20.0	5.0	4		3.42		104302		
8	36	20.0	7.0	4		4.08		104305		
10	32	20.0	7.0	4		4.73		104295		
12	28	20.0	7.0	4		5.38		104296		
1/4	28	20.0	7.0	4		6.24		104293		
5/16	24	25.0	9.0	4		7.82		104300		
3/8	24	30.0	11.0	4		9.41		104298		
7/16	20	30.0	11.0	5		10.98		104303		
1/2	20	38.0	10.0	5		12.56		104292		
9/16	18	38.0	10.0	5		14.14		104306		
5/8	18	45.0	14.0	5		15.73		104301		
3/4	16	45.0	14.0	6		18.89		104297		
7/8	14	55.0	16.0	5		22.05		104304		
1	12	55.0	16.0	6		25.21		104294		
1 1/4	12	65.0	18.0	7		31.56		104289		
1 1/2	12	75.0	20.0	7		37.91		111390		

UNEF, UNS, UN

















ANSI B1.1

HSS



N5120						N5120			
Ø" d ₁ UNEF	P TPI	d ₂ mm	l ₁ mm	⊕	→2A←	ID			
12	32	20.0	7.0	4	5.39	104278			
1/4	32	20.0	7.0	4	6.25	104275			
5/16	32	25.0	9.0	4	7.84	104283			
3/8	32	30.0	11.0	4	9.42	104282			
7/16	28	30.0	11.0	5	11.00	104285			
1/2	28	38.0	10.0	5	12.59	104274			
9/16	24	38.0	10.0	5	14.17	104287			
5/8	24	45.0	14.0	5	15.75	104284			
3/4	20	45.0	14.0	5	18.91	104281			
13/16	20	45.0	14.0	6	20.50	* 104279			
7/8	20	55.0	16.0	5	22.09	* 104286			
1	20	55.0	16.0	6	25.26	* 104276			
Ø" d ₁ UNS	P TPI	d ₂ mm	l ₁ mm	⊕	→2A←	ID			
1/4	40	20.0	5.0	4	6.26	104309			
1/4	36	20.0	5.0	4	6.26	104308			
7/16	24	30.0	11.0	5	10.99	104311			
1/2	24	38.0	10.0	5	12.58	104307			
1	14	55.0	16.0	6	25.23	104310			
Ø" d ₁ UN	P TPI	d ₂ mm	l ₁ mm	⊕	→2A←	ID			
1 1/8	8	65.0	25.0	5	28.33	104246			
1 1/4	8	65.0	25.0	6	31.51	104245			
1 1/2	8	75.0	20.0	7	37.85	104244			
1 3/4	8	90.0	22.0	7	44.20	104247			



						N5120	N5120 LH				
<p>N5120</p>   <p>N5120 LH</p>   						 					
						 					
						 					
						 					
\varnothing " d ₁ G	P TPI	d ₂ mm	l ₁ mm		 → A ←	ID	ID				
1/8	28	30.0	11.0	5	9.62	103926					
1/4	19	38.0	10.0	5	13.03	103924	103925				
3/8	19	45.0	14.0	5	16.54	103935	103936				
1/2	14	45.0	14.0	6	20.81	103922	103923				
5/8	14	55.0	16.0	5	22.77	103938					
3/4	14	55.0	16.0	6	26.30	103933	103934				
7/8	14	65.0	18.0	6	30.06	103940					
1	11	65.0	18.0	7	33.07	103928					
1 1/4	11	75.0	20.0	8	41.73	103918					
1 3/8	11	90.0	22.0	7	44.14	* 103921					
1 1/2	11	90.0	22.0	8	47.62	103917					
2	11	105.0	22.0	9	59.43	103932					
2 1/2	11	120.0	22.0	10	74.97	103930					





G DIN ISO 228 (BSP)

Z
MS
HSSE HSS



Z5120		NI		Z5120	MS5120	MS5120	
MS5120							
MS5120							
\varnothing " d ₁ G	P TPI	d ₂ mm	l ₁ mm				
1/8	28	30.0	11.0	5	5	9.62	104761 * 101339 * 142831
1/4	19	38.0	10.0	5	5	13.03	104760 101338 * 142832
3/8	19	45.0	14.0	5	5	16.54	104764 101342 119716
1/2	14	45.0	14.0	6	6	20.81	104759 101337 119243
3/4	14	55.0	16.0	6	6	26.30	104763 101341 119648
1	11	65.0	18.0	8	7	33.07	104762 101340 135186
1 1/2	11	90.0	22.0		8	47.62	* 142830



<p>N5120</p>  	<p>N5120</p> 																																													
	 																																													
<table border="1"> <thead> <tr> <th>Ø" d₁ R</th> <th>P TPI</th> <th>d₂ mm</th> <th>l₁ mm</th> <th>⊕</th> <th>ID</th> </tr> </thead> <tbody> <tr> <td>1/8</td> <td>28</td> <td>30.0</td> <td>11.0</td> <td>5</td> <td>104226</td> </tr> <tr> <td>1/4</td> <td>19</td> <td>38.0</td> <td>14.0</td> <td>5</td> <td>104225</td> </tr> <tr> <td>3/8</td> <td>19</td> <td>45.0</td> <td>14.0</td> <td>5</td> <td>104230</td> </tr> <tr> <td>1/2</td> <td>14</td> <td>45.0</td> <td>18.0</td> <td>6</td> <td>104224</td> </tr> <tr> <td>3/4</td> <td>14</td> <td>55.0</td> <td>22.0</td> <td>6</td> <td>104229</td> </tr> <tr> <td>1</td> <td>11</td> <td>65.0</td> <td>25.0</td> <td>7</td> <td>104227</td> </tr> </tbody> </table>	Ø" d ₁ R	P TPI	d ₂ mm	l ₁ mm	⊕	ID	1/8	28	30.0	11.0	5	104226	1/4	19	38.0	14.0	5	104225	3/8	19	45.0	14.0	5	104230	1/2	14	45.0	18.0	6	104224	3/4	14	55.0	22.0	6	104229	1	11	65.0	25.0	7	104227				
Ø" d ₁ R	P TPI	d ₂ mm	l ₁ mm	⊕	ID																																									
1/8	28	30.0	11.0	5	104226																																									
1/4	19	38.0	14.0	5	104225																																									
3/8	19	45.0	14.0	5	104230																																									
1/2	14	45.0	18.0	6	104224																																									
3/4	14	55.0	22.0	6	104229																																									
1	11	65.0	25.0	7	104227																																									

Richtwerte für den Drehdurchmesser
Turning dimensions for R threads (in mm)

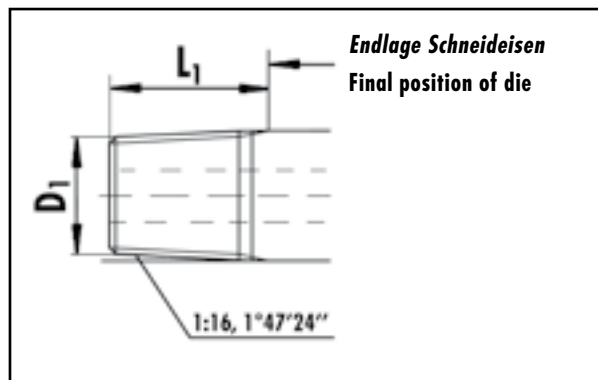

Ø" R	D ₁ mini mm	D ₁ maxi mm	D ₁ (guide line) mm	L ₁ (guide line) mm
1/8	9.422	9.534	9.48	8.2
1/4	12.700	12.863	12.78	12.1
3/8	16.181	16.343	16.26	12.5
1/2	20.330	20.555	20.44	16.4
3/4	25.735	25.960	25.85	17.7
1	32.455	32.743	32.60	20.9

N5120			N5120	N5120
N5120			NPT	NPTF
$\varnothing'' d_1$	P	d_2	l_1	\oplus
NPT, NPTF	TPI	mm	mm	
1/16	27	25.0	9.0	4
1/8	27	30.0	11.0	5
1/4	18	38.0	14.0	5
3/8	18	45.0	14.0	5
1/2	14	45.0	18.0	6
3/4	14	55.0	22.0	6
1	11.5	65.0	25.0	7
1 1/4	11.5	75.0	26.0	8
			ID	ID
			104194	
			104197	* 104207
			104196	
			104201	
			104195	* 104205
			104200	
			104198	* 104208
			104193	

Richtwerte für den Drehdurchmesser

Turning dimensions for NPT and NPTF threads (in mm)

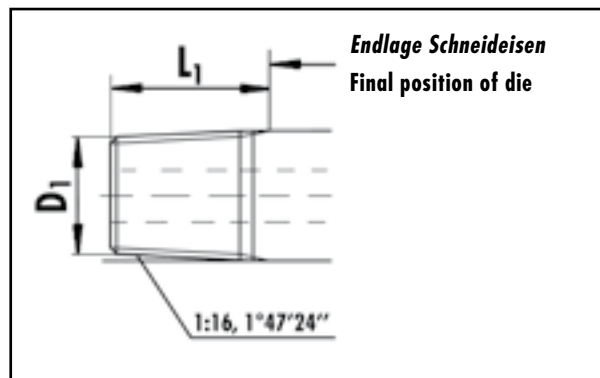

\varnothing'' NPT	D_1 mini mm	D_1 maxi mm	D_1 (guide line) mm	L_1 (guide line) mm	\varnothing'' NPTF	D_1 mini mm	D_1 maxi mm	D_1 (guide line) mm	L_1 (guide line) mm
1/16	7.521	7.643	7.58	8.4	1/16	7.525	7.617	7.57	8.4
1/8	9.866	9.988	9.93	8.5	1/8	9.870	9.962	9.92	8.5
1/4	13.099	13.255	13.18	12.7	1/4	13.129	13.215	13.17	12.7
3/8	16.518	16.674	16.60	12.9	3/8	16.548	16.634	16.59	12.9
1/2	20.551	20.713	20.63	16.8	1/2	20.617	20.703	20.66	16.8
3/4	25.866	26.028	25.95	17.1	3/4	25.932	26.018	25.98	17.1
1	32.419	32.591	32.51	21.3	1	32.475	32.561	32.52	21.3
1 1/4	41.144	41.316	41.23	21.9					

N5120			N5120	N5120		
N5120			PG	TR		

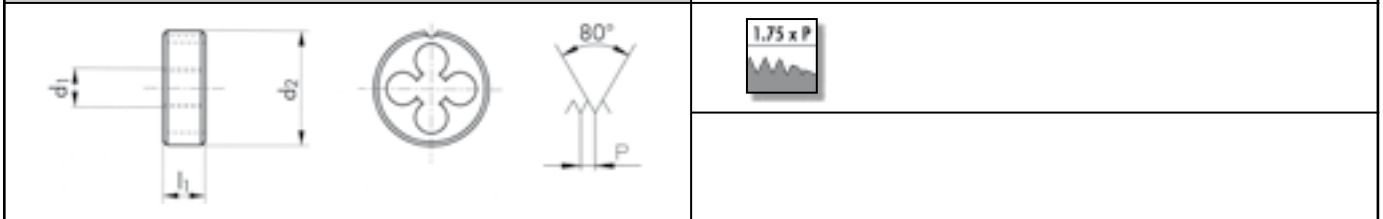

$\varnothing d_1$ PG	P TPI	d_2 mm	l_1 mm	\oplus	$\rightarrow \leftarrow$	ID
7	20	38.0	10.0	5	12.40	104220
9	18	38.0	10.0	5	15.10	104221
11	18	45.0	14.0	5	18.50	104212
13.5	18	45.0	14.0	6	20.30	104213
16	18	55.0	16.0	5	22.40	104214
21	16	65.0	18.0	6	28.15	* 104215
29	16	65.0	18.0	8	36.85	* 104216
36	16	90.0	22.0	8	46.85	* 104217
42	16	90.0	22.0	10	53.85	* 104218
48	16	105.0	22.0	9	59.15	* 104219

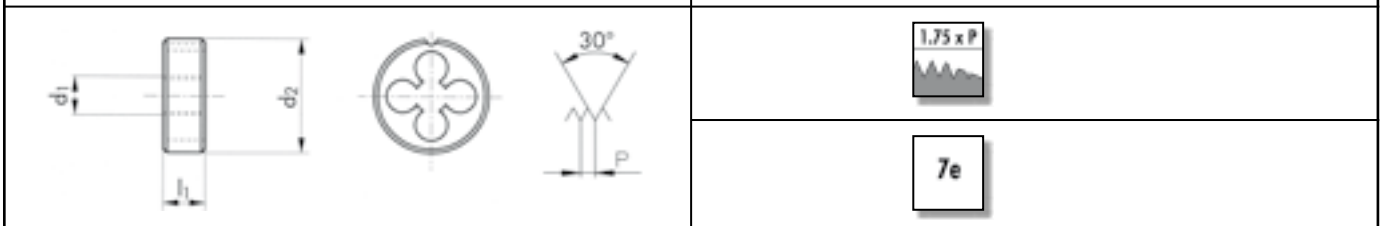













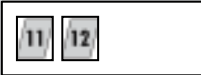



$\varnothing d_1$ TR	P mm	d_2 mm	l_1 mm	\oplus	$\rightarrow \leftarrow$	ID
*10	2	38.0	14.0	4	9.91	* 104231
12	3	38.0	14.0	4	11.88	* 104232
16	4	45.0	18.0	4	15.85	* 104234
26	5	65.0	25.0	5	25.83	* 104239
28	5	65.0	25.0	5	27.83	* 104240
32	6	65.0	25.0	6	31.81	* 104242
36	6	65.0	25.0	6	35.81	* 104243

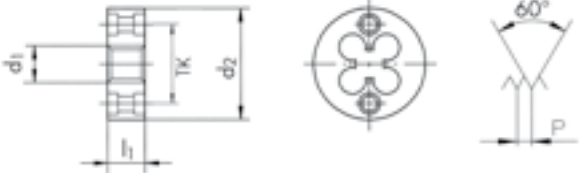

						N5120	N5120 LH		
						MC		MC	
\varnothing'' d_1	P	d_2	l_1	\oplus	$\rightarrow \leftarrow$	ID	ID		
W	TPI	mm	mm						
1/8	40	20.0	5.0	4	3.09	104320			
5/32	32	20.0	7.0	4	3.88	104333			
3/16	24	20.0	7.0	4	4.66	104325			
1/4	20	20.0	7.0	4	6.24	104318			
5/16	18	25.0	9.0	4	7.82	104331			
3/8	16	30.0	11.0	4	9.40	104329			
7/16	14	30.0	11.0	4	10.98	104336			
1/2	12	38.0	14.0	4	12.56	104316			
5/8	11	45.0	18.0	4	15.72	104334	* 104335		
3/4	10	45.0	18.0	5	18.89	104327	* 104328		
7/8	9	55.0	22.0	5	22.10	* 104338			
1	8	55.0	22.0	5	25.27	104322			
1 3/8	6	65.0	25.0	6	34.77	* 104315			



								N5220	N5220	Z5220		
<p>N5220   </p> <p>N5220   </p> <p>Z5220    </p>												
												
								6g	6e	6g		
∅ d ₁ M	P mm	d ₂ mm	l ₁ mm		TK mm			ID	ID ^{6g} - mm	ID		
1.4	0.30	16.0	2.6	4	12.2	1.36		104346				
1.6	0.35	16.0	2.6	4	12.2	1.54		104347				
1.7	0.35	16.0	2.6	4	12.2	1.64		* 104348				
2	0.40	16.0	3.5	4	12.2	1.93	1.90	104367				
2.3	0.40	16.0	3.5	4	12.2	2.23		104369				
2.5	0.45	16.0	3.5	4	12.2	2.43	2.40	104371	* 104370 0.030	104803		
2.6	0.45	16.0	3.5	4	12.2	2.53		104372				
3	0.50	16.0	3.5	4	12.2	2.92	2.90	104375	104374 0.030	104804		
3.5	0.60	16.0	4.0	4	12.2	3.41		104376				
4	0.70	16.0	5.0	4	12.2	3.91	3.87	104380	104379 0.035	104805		
5	0.80	20.0	7.0	4	15.0	4.90	4.87	104384	104383 0.035	104806		
6	1.00	20.0	7.0	4	15.0	5.88	5.85	104388	104387 0.035	104807		
7	1.00	25.0	7.0	4	19.0	6.88		* 104392				
8	1.25	25.0	9.0	4	19.0	7.87	7.83	104397	104396 0.035	104808		
10	1.50	30.0	11.0	6	23.0	9.85	9.82	104354	104353 0.035			
12	1.75	30.0	11.0	6	23.0	11.83		104358				

≤ M1.4

6h







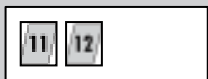

N5220

N5220

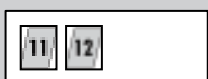
$\varnothing d_1$ MF	P mm	d_2 mm	l_1 mm		TK mm		ID
3	0.35	16.0	3.0	4	12.2	2.94	104373
4	0.35	16.0	3.5	4	12.2	3.94	* 104377
4	0.50	16.0	4.0	4	12.2	3.93	104378
5	0.50	20.0	5.0	4	15.0	4.93	104382
6	0.50	20.0	5.0	4	15.0	5.93	104385
6	0.75	20.0	7.0	4	15.0	5.90	104386
7	0.50	25.0	7.0	4	19.0	6.93	* 104389
7	0.75	25.0	7.0	4	19.0	6.90	* 104390
8	0.75	25.0	7.0	4	19.0	7.90	* 104394
8	1.00	25.0	7.0	4	19.0	7.88	* 104395
10	0.75	30.0	7.0	6	23.0	9.90	* 104350
10	1.00	30.0	7.0	6	23.0	9.88	* 104351
10	1.25	25.0	9.0	6	19.0	9.86	* 104352
12	1.00	30.0	7.0	6	23.0	11.88	* 104355
12	1.50	30.0	11.0	6	23.0	11.85	* 104356
14	1.00	35.0	10.0	6	27.5	13.88	* 104359
14	1.50	35.0	10.0	6	27.5	13.85	* 104360

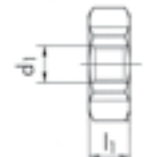

N5310						N5310			
∅ d ₁ M	P mm	s mm	l ₁ mm	⊕	↔	ID			
3	0.50	18.0	5.0	3	2.92	104464			
3.5	0.60	18.0	5.0	3	3.41	* 104465			
4	0.70	18.0	5.0	3	3.91	104478			
4.5	0.75	18.0	7.0	3	4.41	* 104479			
5	0.80	18.0	7.0	4	4.90	104487			
6	1.00	18.0	7.0	4	5.88	104493			
7	1.00	21.0	9.0	4	6.88	* 104497			
8	1.25	21.0	9.0	4	7.87	104502			
9	1.25	21.0	9.0	5	8.87	* 104503			
10	1.50	27.0	11.0	4	9.85	104438			
12	1.75	36.0	14.0	4	11.83	104443			
14	2.00	36.0	14.0	4	13.82	104445			
16	2.00	41.0	18.0	4	15.82	104447			
18	2.50	41.0	18.0	5	17.79	104450			
20	2.50	41.0	18.0	5	19.79	104453			
22	2.50	50.0	22.0	5	21.79	104456			
24	3.00	50.0	22.0	5	23.76	104459			
27	3.00	60.0	25.0	5	26.76	* 104463			
30	3.50	60.0	25.0	5	29.73	104468			
52	5.00	85.0	36.0	8	51.66	* 104489			
∅ d ₁ MF	P mm	s mm	l ₁ mm	⊕	↔	ID			
6	0.75	18.0	7.0	4	5.90	* 104492			
8	0.75	21.0	9.0	4	7.90	* 104500			
8	1.00	21.0	9.0	4	7.88	* 104501			
12	1.00	36.0	10.0	4	11.88	* 104440			
20	1.50	41.0	14.0	6	19.85	* 104451			
27	1.50	60.0	18.0	6	26.85	* 104461			
27	2.00	60.0	18.0	6	26.82	* 104462			
30	2.00	60.0	18.0	6	29.82	* 104467			
33	1.50	60.0	18.0	7	32.85	* 104469			
33	2.00	60.0	18.0	7	32.82	* 104470			
38	1.50	70.0	20.0	8	37.85	* 104475			
39	1.50	70.0	20.0	8	38.85	* 104476			
40	1.50	70.0	20.0	8	39.85	* 104480			
64	2.00	115.0	22.0	8	63.82	* 104495			

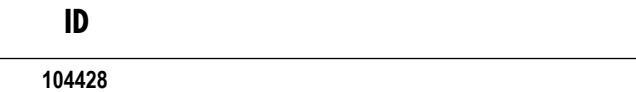
N5310						N5310	N5310	N5420
								
								
 								
  								
$\varnothing'' d_1$ G	P TPI	s mm	l_1 mm	\oplus	$\rightarrow \leftarrow$	ID		
1/4	19	36.0	10.0	5	13.03	104428		
3/8	19	41.0	14.0	5	16.54	104433		
1/2	14	41.0	14.0	6	20.81	104427		
5/8	14	50.0	16.0	6	22.77	* 104434		
3/4	14	50.0	16.0	6	26.30	104432		
7/8	14	60.0	18.0	6	30.06	* 104435		
1	11	60.0	18.0	7	33.07	104430		
1 3/8	11	85.0	22.0	7	44.14	* 104426		
1 3/4	11	100.0	22.0	8	53.57	* 104425		
$\varnothing'' d_1$ W	P TPI	s mm	l_1 mm	\oplus	$\rightarrow \leftarrow$	ID		
1/8	40	18.0	5.0	3	3.09	* 104512		
3/16	24	18.0	7.0	3	4.66	* 104515		
7/16	14	27.0	11.0	5	10.98	* 104520		
9/16	12	36.0	14.0	4	14.14	* 104522		
7/8	9	50.0	22.0	5	22.10	* 104521		
1 3/8	6	60.0	25.0	6	34.77	* 104508		
1 1/2	6	70.0	30.0	6	37.95	* 104504		
1 3/4	5	85.0	36.0	6	44.28	* 104507		
2	4.5	85.0	36.0	7	50.63	* 104514		
$\varnothing d_1$ M	P mm	d_2 mm	l_1 mm	\oplus	$\rightarrow \leftarrow$	ID		
2.5	0.45	16.0	8.0	4	2.43	* 104527		
3.5	0.60	16.0	9.5	4	3.41	* 104530		
4	0.70	16.0	9.5	4	3.90	* 104531		
8	1.25	25.0	14.0	5	7.86	* 104535		

Inhaltsverzeichnis - Gewindelehrdorne und Gewindelehrringe

Directory - Screw thread plug and ring gauges

Merkmale Characteristics								
								
		D5701-1	D5701-2	D5703		D5720	D5722	D5725
M 6H / 6g	ISO DIN 13	266	266	266				
M 6G / 6e	ISO DIN 13			266				
M 6H / 6g LH	ISO DIN 13			266				
MF 6H / 6g	ISO DIN 13	268-269	269	268-269				
MF 6G / 6e	ISO DIN 13			268				
MF 6H / 6g LH	ISO DIN 13			268				
UNC	ANSI B1.1	272		272				
UNF	ANSI B1.1	273		273				
UNEF	ANSI B1.1			273				
NPT	ANSI B1.20.1					275		
NPTF	ANSI B1.20.3					275		
G (BSP)	DIN ISO 228	274	274	274				
PG	DIN 40430							274
EG M	ISO DIN 8140			276				
EG UNC	NASM 33537			276				
EG UNF	NASM 33537			276				

D5704	D5714	D5721	D5723
267	267		
267	267		
267			
270-271	270-271		
270			
272	272		
273	273		
273	273		
		275	
		275	
274	274		
274			

Piktogramme - Pictographs



"Gut"
"Go"



"Ausschuss"
"No-go"



"Gut / Ausschuss"
"Go" / "No-go"



Toleranz 6H, "Gut"
Tolerance 6H, "Go"











Toleranz 6G, "Gut" / "Ausschuss"
Tolerance 6G, "Go" / "No-go"











Toleranz 6g, "Ausschuss"
Tolerance 6g, "No-go"















Linksgewinde
Left hand thread

		D5701-1	D5701-2	D5703	D5703 LH	D5703	
D5701-1 M1 - M1.4 =  D5703 M1 - M1.4 = 							
					 LH		
∅ d ₁ M	P mm	ID	ID	ID	ID	ID	
1	0.25			100242			
1.1	0.25			100243			
1.2	0.25			100244			
1.4	0.30			100245			
1.6	0.35			100246	* 110168		
1.7	0.35			100247			
1.8	0.35			100248	* 110169		
2	0.40			100278	105159	104982	
2.2	0.45			100280			
2.3	0.40			100281			
2.5	0.45			100283	105160	104979	
2.6	0.45	* 100064		100285			
3	0.50			100310	104964	104976	
3.5	0.60			100312		104977	
4	0.70			100333	104966	104978	
4.5	0.75	* 100114					
5	0.80			100348	104967	104980	
6	1.00			100363	104968	104981	
7	1.00			100369	* 110186		
8	1.25			100373	104969	104983	
9	1.25			100375			
10	1.50			100253	104970	104984	
11	1.50			* 100256			
12	1.75			100261	104971	104985	
14	2.00	* 100045		100266		104986	
16	2.00			100271	104973	104987	
18	2.50	* 100055		100276		* 104988	
20	2.50	* 100068		100289	104975	104989	
22	2.50	* 100072		100293	* 110178		
24	3.00	* 100076		100297	110179		
27	3.00			100305	* 110180		
30	3.50			100316			
33	3.50	* 100101		100322			
36	4.00	* 100107		100328			
39	4.00	* 100109		100330			
42	4.50	100119	142843				
45	4.50	100122	142844				
48	5.00	100125	142845				
52	5.00	100132	142846				
56	5.50	100137	142847				



		D5704	D5704 LH	D5704	D5714	D5714	
D5704 M1 - M1.4 =  D5714 M1 - M1.4 = 							
			 LH				
$\varnothing d_1$ M	P mm	ID	ID	ID	ID	ID	
1	0.25	100480			110419		
1.2	0.25	100481			110420		
1.4	0.30	100482			110421		
1.6	0.35	100483			110422		
1.7	0.35	100484			111439		
1.8	0.35	100485			110423		
2	0.40	100515	105006	* 104997	100734	* 142833	
2.2	0.45	100517			100735		
2.3	0.40	100518			100736		
2.5	0.45	100520		* 104991	100737	* 142834	
2.6	0.45	100522			100738		
3	0.50	100547	105001	* 104990	100763	* 142835	
3.5	0.60	100549	110302	* 110301	100765	* 142836	
4	0.70	100570	105003	* 104992	100774	* 142837	
5	0.80	100585	105004	* 104993	100778	* 143406	
6	1.00	100600	105005	* 104994	100781	* 135556	
7	1.00	100605	* 126560	* 104995	100783	* 142840	
8	1.25	100611	105007	* 104996	100786	* 142841	
9	1.25	100610			100788		
10	1.50	100490	105008	* 104998	100711	* 142842	
11	1.50	* 100493			* 100713		
12	1.75	100498	105009		100718		
14	2.00	100503	105010		100723		
16	2.00	100508	105011	* 105000	100728		
18	2.50	100513	105012		100733		
20	2.50	100526	105013		100742		
22	2.50	100530	110298		100746		
24	3.00	100534			100750		
27	3.00	100542			100758		
30	3.50	100553			100769		
33	3.50	* 100559			* 100770		
36	4.00		* 110305				
39	4.00				* 110440		
42	4.50	* 100577					
45	4.50	* 100580			* 110448		
48	5.00				* 110451		
52	5.00	* 100590			* 110456		
56	5.50	* 100595			* 110461		





		D5701-1	D5703	D5703 LH	D5703		
							
				 			
$\varnothing d_1$ MF	P mm	ID	ID	ID	ID		
2.5	0.35		100282				
3	0.35		100309				
4	0.35		100331				
4	0.50		100332				
4.5	0.50		* 100334				
5	0.50		100347	105016	105045		
6	0.50	* 100140	100361	110184			
6	0.75		100362		105046		
7	0.50		100367				
7	0.75	* 100147	100368				
8	0.50	* 100149	100370				
8	0.75		100371	105018	105047		
8	1.00	* 100151	100372	105019	105048		
9	1.00		100374				
10	0.50		100249				
10	0.75		100250				
10	1.00		100251	105020	105049		
10	1.25	* 100031	100252				
11	0.75	* 100033					
11	1.00	* 100034	100255				
12	0.75	* 100036	100257				
12	1.00		100258	105021	105050		
12	1.25		100259				
12	1.50	* 100039	100260	105022			
14	1.00		100263	110171			
14	1.25		100264				
14	1.50	* 100044	100265	105023	105052		
15	1.00	* 100046	100267				
15	1.50		100268				
16	1.00		100269	110172			
16	1.50	* 100049	100270	105024	105053		
17	1.00		100272				
18	1.00		100273				
18	1.50	* 100053	100274	105025	105054		
18	2.00	* 100054	100275				
20	1.00	* 100065	100286				
20	1.50		100287	105026			
20	2.00	* 100067	100288		* 110176		
22	1.00		100290				
22	1.50		100291	110177			
22	2.00		100292				
24	1.00		100294				
24	1.50		100295				
24	2.00		100296				

		D5701-1	D5701-2	D5703			
							
							
$\varnothing d_1$ MF	P mm	ID	ID	ID			
25	1.00	* 100077		100298			
25	1.50			100299			
25	2.00			100300			
26	1.00			100301			
26	1.50	* 100081		100302			
27	1.50	* 100082		100303			
27	2.00	* 100083		100304			
28	1.00			100306			
28	1.50	* 100086		100307			
28	2.00	* 100087		100308			
30	1.00	* 100092		100313			
30	1.50			100314			
30	2.00			100315			
32	1.00			100317			
32	1.50	* 100097		100318			
32	2.00			100319			
33	1.50			100320			
33	2.00	* 100100		100321			
35	1.50	* 100102		100323			
36	1.50	* 100104		100325			
36	2.00			100326			
36	3.00			100327			
38	1.50	* 100108		100329			
40	1.50			100336			
40	2.00			100337			
42	1.50	100117	142848				
42	2.00	100118	142849				
45	1.50	100120	110127				
45	2.00	100121	142851				
48	1.50	100123	123180				
48	2.00	100124	142853				
50	1.50	100128	142854				
50	2.00	100129	142855				
52	1.50	100130	123428				
52	2.00	100131	142857				
55	1.50	100133	123468				
55	2.00	100134	142859				
56	1.50	100135	142860				
56	2.00	100136	142861				
58	1.50	100138	142862				
58	2.00	100139	142863				
60	1.50	100143	142864				
60	2.00	100144	142865				











		D5704	D5704 LH	D5714			
							
							
$\varnothing d_1$ MF	P mm	ID	ID	ID			
2.5	0.35	100519		110427			
3	0.35	100546		100762			
3.5	0.35	100548		100764			
4	0.35	100568		100772			
4	0.50	100569		100773			
4.5	0.50	100571		100775			
5	0.50	100584	105057	100777			
6	0.50	100598	110307	100779			
6	0.75	100599	105058	100780			
7	0.50	100603		110467			
7	0.75	100604		100782			
8	0.50	100606					
8	0.75	100607	* 105059	100784			
8	1.00	100608	105060	100785			
9	1.00	100609		100787			
10	0.50	100486		100707			
10	0.75	100487		100708			
10	1.00	100488	105061	100709			
10	1.25	100489		100710			
11	1.00	100492		100712			
12	0.75	100494		100714			
12	1.00	100495	105062	100715			
12	1.25	100496		100716			
12	1.50	100497	105063	100717			
13	1.00	100499		100719			
14	1.00	100500	110290	100720			
14	1.25	100501		100721			
14	1.50	100502	105064	100722			
15	1.00	100504		100724			
15	1.50	100505		100725			
16	1.00	100506	110292	100726			
16	1.50	100507	105065	100727			
17	1.00	100509		100729			
18	1.00	100510		100730			
18	1.50	100511	105066	100731			
20	1.00	100523	110295	100739			
20	1.50	100524	105067	100740			
20	2.00	100525		100741			
22	1.00	100527		100743			
22	1.50	100528		100744			
22	2.00	100529		100745			
24	1.00	100531		100747			
24	1.50	100532		100748			
24	2.00	100533					

		D5704	D5714				
							
							
Ø d ₁ MF	P mm	ID	ID				
25	1.00	100535					
25	1.50	100536					
26	1.00	100538	* 100754				
26	1.50	100539	* 100755				
27	1.50	100540	* 100756				
27	2.00	100541	* 100757				
28	1.00	100543					
28	1.50	100544	* 100760				
30	1.00	100550					
30	1.50	100551					
30	2.00	100552	* 100768				
32	1.00	100554					
32	1.50	100555					
32	2.00	100556	* 110431				
33	1.50	100557	* 110432				
33	2.00	100558	* 110433				
35	1.50	100560					
36	1.50	100562					
36	2.00	100563					
36	3.00	100564					
38	1.50	100566	* 110439				
40	1.50	100573	* 110441				
42	1.50	100575					
42	2.00	100576					
45	1.50	100578					
45	2.00	100579	* 110447				
48	1.50	100581	* 110449				
48	2.00	100582					
50	1.50	100586	* 110452				
50	2.00	100587	* 110453				
52	1.50		* 110454				
52	2.00	100589					
55	1.50	100591					
55	2.00	100592	* 110458				
56	1.50	100593	* 110459				
56	2.00	100594	* 110460				
58	1.50	100596					
58	2.00	100597	* 110463				
60	1.50	100601	* 110464				
60	2.00	105014					



UNC









ANSI B1.1
ANSI B1.2

		D5701-1	D5703	D5704	D5714		
							
							
Ø" d ₁ UNC	P TPI	ID	ID	ID	ID		
1	64		100408	110347	110473		
2	56	* 110076	100414	110353	110479		
3	48	* 110077	100416		* 110480		
4	40	* 110080	110224	110357	110483		
5	40		100420	* 110358	* 110484		
6	32	* 110084	100423	110361	110487		
8	32	* 110087	100426	110364	110490		
10	24	* 110074	100412	110351	110477		
12	24		100413				
1/4	20		100410	110349	110475		
5/16	18	* 110082	100421	110359	110485		
3/8	16	* 110079	100418	110356	110482		
7/16	14	* 110085	100424	110362	110488		
1/2	13	* 110071	100409	110348	110474		
9/16	12		100427	110365	* 110491		
5/8	11	* 110083	100422	110360			
3/4	10	* 110078	100417	110355	* 110481		
7/8	9		100425	110363	* 110489		
1	8	* 110073	100411	110350	* 110476		
1 1/8	7	* 110068	100405	* 110345	* 110471		
1 1/4	7	* 110067	100404	* 110344	* 110470		
1 3/8	6	* 110069	100407	* 110346	* 110472		
1 1/2	6	* 110066	100403	* 110343	* 110469		













UNF, UNEF

ANSI B1.1

ANSI B1.2

		D5701-1	D5703	D5704	D5714		
							
							
\varnothing " d ₁ UNF	P TPI	ID	ID	ID	ID		
0	80		110246	* 110378	* 110503		
1	72	* 110105	110251	110383	110508		
2	64		110256	110389	110514		
3	56	* 110112	110257	110390	110515		
4	48		110260	110393	110518		
5	44	* 110116	* 110261				
6	40		110264	110397	110522		
8	36	* 110122	110267	* 110400			
10	32		110254	110387	110512		
12	28		110255	110388	110513		
1/4	28	* 110107	110006	110385	110510		
5/16	24	* 110117	110262	110395	110520		
3/8	24	* 110114	110259	110392	110517		
7/16	20	* 110120	110265	110398	111440		
1/2	20	* 110106	110252	110384	110509		
9/16	18		110268	110401			
5/8	18	* 110118	110263	110396			
3/4	16		110258	110391	* 110516		
7/8	14		110266	110399			
1	12		128646	110386			
1 1/8	12	* 110103	110249	110381	* 110506		
1 1/4	12	* 110102	110248	110380	* 110505		
1 3/8	12	* 110104	110250	* 110382	* 110507		
1 1/2	12		110247	110379			
\varnothing " d ₁ UNEF	P TPI	ID	ID	ID	ID		
12	32		110238	* 110370	* 110495		
1/4	32		110236	110368	110493		
5/16	32		110241	110373	110498		
3/8	32		110240	110372	110497		
7/16	28		110243	110375	110500		
1/2	28		110235	110367	110492		
9/16	24		110245	110377	110502		
5/8	24		110242	110374	110499		
3/4	20		110239	110371	110496		
7/8	20		110244		* 110501		
1	20		110253	110369	110494		





		D5701-1	D5701-2	D5703	D5704	D5714	D5725	
								
								
\varnothing d ₁ G	P TPI	ID	ID	ID	ID	ID		
1/8	28	* 110044		110009	110277	110408		
1/4	19			110003	110276	110407		
3/8	19	* 110052		110162	110284	110415		
1/2	14			110001	110275	110406		
5/8	14			110164	110286	110417		
3/4	14			110161	110283	110414		
7/8	14	* 110054		110165	* 110287	* 110418		
1	11			110156	110278	110409		
1 1/8	11			110154		* 110404		
1 1/4	11	110041	119459		110272			
1 1/2	11	110040	119429		110271			
1 3/4	11	110043	142868		110274	* 110405		
2	11	110050	110126		110282			
2 1/4	11					* 110411		
2 1/2	11		* 110125					
2 3/4	11					* 110412		
3	11				* 110285	* 110416		
\varnothing d ₁ PG	P TPI	ID				ID		
7	20					110216		
9	18					110217		
11	18					110205		
13.5	18					110209		
16	18					* 110330	110210	
21	16					* 110331	110211	
29	16					* 110332	110212	

NPT, NPTF



ANSI B1.20.1 / ANSI B1.20.3

ANSI B1.20.1 / ANSI B1.20.5

		D5720	D5721				
							
							
\varnothing " d ₁ NPT	P TPI	ID	ID				
1/16	27	110190	110313				
1/8	27	110193	110316				
1/4	18	110192	110315				
3/8	18	110197	110320				
1/2	14	110191	110314				
3/4	14	110196	110319				
1	11.5	110194	110317				
1 1/4	11.5	110189	110312				
1 1/2	11.5	110188	110311				
2	11.5	110195	110318				
\varnothing " d ₁ NPTF	P TPI	ID	ID				
1/8	27	110201	* 110324				
1/4	18	110200	* 110323				
3/8	18	110204	* 110327				
1/2	14	110199	* 110322				
3/4	14	110203	* 110326				
1	11.5	110202	* 110325				



EG M ISO DIN 8140 ISO DIN 1502 EG UNC, EG UNF NASM 33537

		D5703	D5703	D5703			
							
							
$\varnothing d_1$ EG M	P mm	ID					
2.5	0.45	110132					
3	0.50	110133					
4	0.70	110134					
5	0.80	110135					
6	1.00	110136					
8	1.25	110137					
10	1.50	110128					
12	1.75	110129					
16	2.00	110131					
\varnothing " d ₁ EG UNC	P TPI	ID					
4	40	170252					
6	32	170253					
8	32	170254					
10	24	170255					
1/4	20	170256					
5/16	18	170257					
3/8	16	170258					
\varnothing " d ₁ EG UNF	P TPI	ID					
6	40	170259					
8	36	170260					
10	32	161020					
1/4	28	151790					
5/16	24	170261					
3/8	24	160134					



SYNCHRO



SRT Synchron-Gewindeschneidfutter mit Axial-Stossdämpfer

Tapping chucks with axial shock absorber



Uniquement pour taraudage synchrone
 Nur für Synchronbearbeitung
 Only for rigid tapping
 Solo per maschiatura sincrona
 Solo para roscado sincronizado







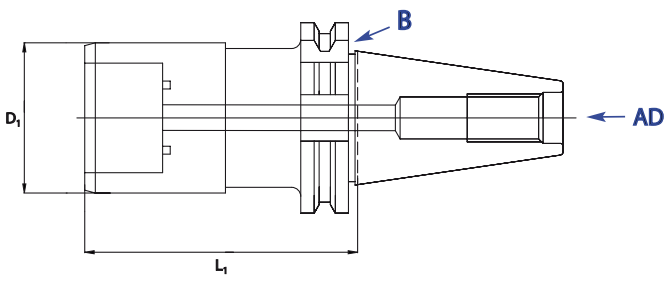

DIN 69 893 A					SRT-HSK63-312	SRT-HSK63-520	SRT-HSK63-1433
<h1>HSK</h1>							
D_1 mm	L_1 mm			282	ID	ID	ID
M3 - M12	36 72.0	HSK A 63	S1		170111		
M5 - M20	53 89.0	HSK A 63	S2			170112	
M14 - M33	78 121.0	HSK A 63	S3				170114
MAS/BT Form AD + B					SRT-BT40-312	SRT-BT40-520	SRT-BT40-1433
<h1>BT</h1>							
D_1 mm	L_1 mm			282	ID	ID	ID
M3 - M12	36 71.0	BT 40	S1		170133		
M5 - M20	53 85.0	BT 40	S2			170134	
M14 - M33	78 121.0	BT 40	S3				170135

SRT Synchron-Gewindeschneidfutter mit Axial-Stossdämpfer

Tapping chucks with axial shock absorber

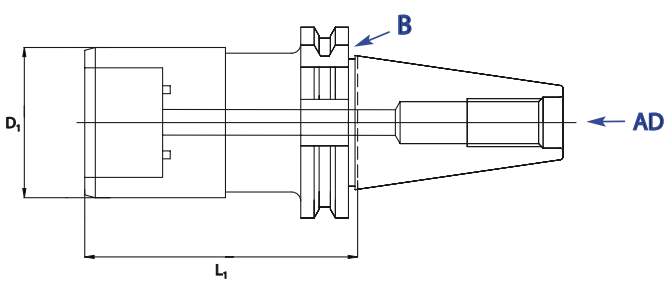

Uniquement pour taraudage synchrone
Nur für Synchronbearbeitung
Only for rigid tapping
Solo per maschiatura sincrona
Solo para roscado sincronizado

DIN 69 871 Form AD + B					SRT-SK40-312	SRT-SK40-520	SRT-SK40-1433
<h1>SK</h1>							
							
  282					ID	ID	ID
M3 - M12	36	65.0	SK 40	S1	170124		
M5 - M20	53	79.0	SK 40	S2		170125	
M14 - M33	78	115.0	SK 40	S3			170126
DIN 69 871 Form AD + B					SRT-SK50-520	SRT-SK50-1433	SRT-SK50-2248
<h1>SK</h1>							
							
  282					ID	ID	ID
M5 - M20	53	79.0	SK 50	S2	170128		
M14 - M33	78	115.0	SK 50	S3		170129	
M22 - M48	96	170.0	SK 50	S4			170130



SRT Synchron-Gewindeschneidfutter mit Axial-Stossdämpfer

Tapping chucks with axial shock absorber



Uniquement pour taraudage synchrone
Nur für Synchronbearbeitung
Only for rigid tapping
Solo per maschiatura sincrona
Solo para roscado sincronizado













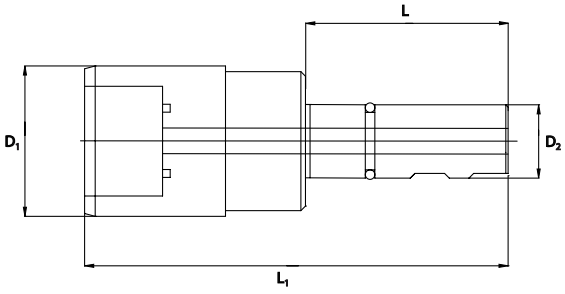









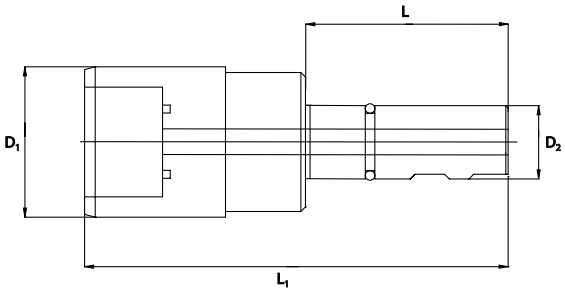

DIN 1835 B							SRT032-D6	SRT054-D12	ER8
SRT nano									
SRT032 / SRT054			D9865-						
	D	D ₁	D ₂	L	L ₁	L ₂	ID	ID	
	mm	mm	mm	mm	mm	mm			
M0.3 - M2	12	11	6	25	40	56.0	157610		
M0.5 - M4	12	20	12	33	59	75.0		127413	
No	D ₂	L ₃	d ₂	ID					
	mm	mm	mm						
ER8-0200	8.5	13.5	2.0	118895					
ER8-0250	8.5	13.5	2.5	118896					
ER8-0300	8.5	13.5	3.0	118897					
ER8-0350	8.5	13.5	3.5	118898					
ER8-0400	8.5	13.5	4.0	118899					
ER8-0450	8.5	13.5	4.5	118900					
DIN 1835 B							SRT312-D20	SRT312-D25	SRT520-D25
SRT short									
	D ₁	D ₂	L	L ₁			ID	ID	ID
	mm	mm	mm	mm					
M3 - M12	39	20	47	86.0	S1		162832		
M3 - M12	39	25	53	90.0	S1			162831	
M5 - M20	56	25	53	110.0	S2				162833

SRT Synchron-Gewindeschneidfutter mit Axial-Stossdämpfer

Tapping chucks with axial shock absorber



Uniquement pour taraudage synchrone
Nur für Synchronbearbeitung
Only for rigid tapping
Solo per maschiatura sincrona
Solo para roscado sincronizado

DIN 1835 B	SRT-1D20-312	SRT-1D25-312	SRT-2D25-520																												
SRT																															
	 <50 bar	 <50 bar	 <50 bar																												
<table border="1"> <thead> <tr> <th></th> <th>D₁ mm</th> <th>D₂ mm</th> <th>L mm</th> <th>L₁ mm</th> <th></th> <th> 282</th> </tr> </thead> <tbody> <tr> <td>M3 - M12</td> <td>36</td> <td>20</td> <td>51.0</td> <td>97</td> <td>S1</td> <td></td> </tr> <tr> <td>M3 - M12</td> <td>36</td> <td>25</td> <td>57.0</td> <td>103</td> <td>S1</td> <td></td> </tr> <tr> <td>M5 - M20</td> <td>53</td> <td>25</td> <td>57.0</td> <td>131</td> <td>S2</td> <td></td> </tr> </tbody> </table>		D ₁ mm	D ₂ mm	L mm	L ₁ mm		 282	M3 - M12	36	20	51.0	97	S1		M3 - M12	36	25	57.0	103	S1		M5 - M20	53	25	57.0	131	S2		ID 170140	ID 170020	ID 170141
	D ₁ mm	D ₂ mm	L mm	L ₁ mm		 282																									
M3 - M12	36	20	51.0	97	S1																										
M3 - M12	36	25	57.0	103	S1																										
M5 - M20	53	25	57.0	131	S2																										
DIN 1835 B	SRT-2D32-520	SRT-3D25-1433	SRT-3D32-1433																												
SRT																															
	 <50 bar	 <50 bar	 <50 bar																												
<table border="1"> <thead> <tr> <th></th> <th>D₁ mm</th> <th>D₂ mm</th> <th>L mm</th> <th>L₁ mm</th> <th></th> <th> 282</th> </tr> </thead> <tbody> <tr> <td>M5 - M20</td> <td>53</td> <td>32</td> <td>61.5</td> <td>135.5</td> <td>S2</td> <td></td> </tr> <tr> <td>M14 - M33</td> <td>78</td> <td>25</td> <td>57.0</td> <td>164.5</td> <td>S3</td> <td></td> </tr> <tr> <td>M14 - M33</td> <td>78</td> <td>32</td> <td>61.5</td> <td>169.0</td> <td>S3</td> <td></td> </tr> </tbody> </table>		D ₁ mm	D ₂ mm	L mm	L ₁ mm		 282	M5 - M20	53	32	61.5	135.5	S2		M14 - M33	78	25	57.0	164.5	S3		M14 - M33	78	32	61.5	169.0	S3		ID 170142	ID 170143	ID 170144
	D ₁ mm	D ₂ mm	L mm	L ₁ mm		 282																									
M5 - M20	53	32	61.5	135.5	S2																										
M14 - M33	78	25	57.0	164.5	S3																										
M14 - M33	78	32	61.5	169.0	S3																										



SRT

Einsätze ohne Sicherheitskupplung
Inserts without slipping clutch



Uniquement pour taraudage synchrone
 Nur für Synchrobearbeitung
 Only for rigid tapping
 Solo per maschiatura sincrona
 Solo para roscado sincronizado

SRT					S1-	S2-	S3-	S4-
No	D ₁ mm	D ₂ mm	d ₂ mm	α mm	ID	ID	ID	ID
S1-0028	30	19.0	2.8	2.1	129915			
S1-0035	30	19.0	3.5	2.7	129916			
S1-0045	30	19.0	4.5	3.4	129918			
S1-0060	30	19.0	6.0	4.9	129920			
S1-0070	30	19.0	7.0	5.5	129921			
S1-0080	30	19.0	8.0	6.2	129922			
S1-0090	30	19.0	9.0	7.0	129923			
S1-0100	30	19.0	10.0	8.0	129924			
S1-0110	30	19.0	11.0	9.0	129925			
S2-0060	48	31.0	6.0	4.9		129927		
S2-0070	48	31.0	7.0	5.5		129928		
S2-0080	48	31.0	8.0	6.2		129929		
S2-0090	48	31.0	9.0	7.0		129930		
S2-0100	48	31.0	10.0	8.0		129931		
S2-0110	48	31.0	11.0	9.0		148303		
S2-0120	48	31.0	12.0	9.0		129932		
S2-0140	48	31.0	14.0	11.0		129933		
S2-0160	48	31.0	16.0	12.0		129934		
S2-0180	48	31.0	18.0	14.5		151355		
S3-0110	70	48.0	11.0	9.0			170145	
S3-0120	70	48.0	12.0	9.0			170146	
S3-0140	70	48.0	14.0	11.0			170147	
S3-0160	70	48.0	16.0	12.0			170148	
S3-0180	70	48.0	18.0	14.5			170149	
S3-0200	70	48.0	20.0	16.0			170150	
S3-0220	70	48.0	22.0	18.0			170151	
S3-0250	70	48.0	25.0	20.0			170152	
S4-0180	96	60.0	18.0	14.5				170153
S4-0200	96	60.0	20.0	16.0				170154
S4-0220	96	60.0	22.0	18.0				170155
S4-0250	96	60.0	25.0	20.0				170156
S4-0280	96	60.0	28.0	22.0				170157
S4-0320	96	60.0	32.0	24.0				170158
S4-0360	96	60.0	36.0	29.0				170159

Einsätze mit Sicherheitskupplung
Inserts with slipping clutch



CLASSIC

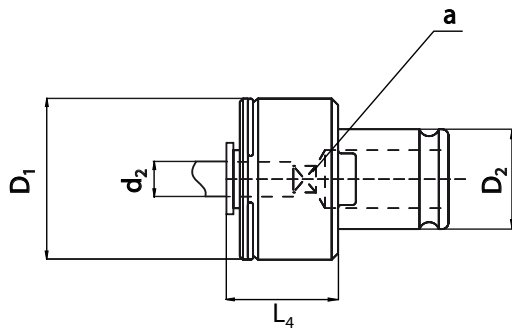

SC1-

SC2-

SC3-

SC4-



No	D_1 mm	D_2 mm	d_2 mm	a mm	L_4 mm	ID	ID	ID	ID
SC1-0028	32	19.0	2.8	2.1	25	170160			
SC1-0035	32	19.0	3.5	2.7	25	170161			
SC1-0045	32	19.0	4.5	3.4	25	170162			
SC1-0060	32	19.0	6.0	4.9	25	170163			
SC1-0070	32	19.0	7.0	5.5	25	170164			
SC1-0080	32	19.0	8.0	6.2	25	170165			
SC1-0090	32	19.0	9.0	7.0	25	170166			
SC1-0100	32	19.0	10.0	8.0	25	170167			
SC2-0060	50	31.0	6.0	4.9	34		170168		
SC2-0070	50	31.0	7.0	5.5	34		170169		
SC2-0080	50	31.0	8.0	6.2	34		170170		
SC2-0090	50	31.0	9.0	7.0	34		170171		
SC2-0100	50	31.0	10.0	8.0	34		170172		
SC2-0110	50	31.0	11.0	9.0	34		170173		
SC2-0120	50	31.0	12.0	9.0	34		170174		
SC2-0140	50	31.0	14.0	11.0	34		170175		
SC2-0160	50	31.0	16.0	12.0	34		170176		
SC2-0180	50	31.0	18.0	14.5	34		170177		
SC3-0110	72	48.0	11.0	9.0	45			170178	
SC3-0120	72	48.0	12.0	9.0	45			170179	
SC3-0140	72	48.0	14.0	11.0	45			170180	
SC3-0160	72	48.0	16.0	12.0	45			170181	
SC3-0180	72	48.0	18.0	14.5	45			170182	
SC3-0200	72	48.0	20.0	16.0	45			170183	
SC3-0220	72	48.0	22.0	18.0	45			170184	
SC3-0250	72	48.0	25.0	20.0	45			170185	
SC4-0180	96	60.0	18.0	14.5	68				170186
SC4-0200	96	60.0	20.0	16.0	68				170187
SC4-0220	96	60.0	22.0	18.0	68				170188
SC4-0250	96	60.0	25.0	20.0	68				170189
SC4-0280	96	60.0	28.0	22.0	68				170190
SC4-0320	96	60.0	32.0	24.0	68				170191
SC4-0360	96	60.0	36.0	29.0	68				170192



Vollhartmetall-Spiralbohrer

Solid carbide twist drills























sur demande
auf Anfrage
on request
su richiesta
sobre pedido

							F313VS	F285VS	F286VS			
<p>F313VS</p> <p>F285VS F286VS</p>												
$\varnothing d_1$ (h_7)	d_2 (h_6) mm	l_1 mm	l_2 mm				ID					
0.88	3.0	38.0	8.0	2	M 1		158515					
1.08	3.0	38.0	10.0	2	M 1.2		158516					
1.25	3.0	38.0	12.0	2	M 1.4		158517					
1.45	3.0	38.0	12.0	2	M 1.6		158518					
1.65	3.0	38.0	12.0	2	M 1.8		158519					
1.80	3.0	38.0	12.0	2	M 2		158520					
1.95	3.0	38.0	12.0	2	UNC 2-56		158521					
2.30	3.0	38.0	16.0	2	M 2.5		158522					
2.55	3.0	38.0	16.0	2	UNC 4-40		158523					
2.80	3.0	38.0	16.0	2	M 3		158524					
							ID					
$\varnothing d_1$ (m_7)	d_2 (h_6) mm	l_1 mm	l_2 mm	l_3 mm								
3.25	6.0	62.0	20.0	14.0	2	M 3.5	158527					
3.70	6.0	62.0	20.0	14.0	2	M 4	158528					
4.65	6.0	66.0	24.0	17.0	2	M 5	158532					
5.55	6.0	66.0	28.0	20.0	2	M 6	158534					
7.40	8.0	79.0	41.0	29.0	2	M 8	158540					
9.30	10.0	89.0	47.0	35.0	2	M 10	158544					
11.20	12.0	102.0	55.0	40.0	2	M 12	158546					
							ID					
$\varnothing d_1$ (m_7)	d_2 (h_6) mm	l_1 mm	l_2 mm	l_3 mm								
3.30	6.0	66.0	28.0	23.0	2	M 4	160989					
4.20	6.0	74.0	36.0	29.0	2	M 5	160990					
5.00	6.0	82.0	44.0	35.0	2	M 6	160991					
6.80	8.0	91.0	53.0	43.0	2	M 8	160992					
8.50	10.0	103.0	61.0	49.0	2	M 10	160993					
10.20	12.0	118.0	71.0	56.0	2	M 12	160994					

Gewindeschneid-Sortimente

Tap assortments

Boxset		D5855	D5860	D5891
D5855	  N1110-S M3, M4, M5, M6, M8, M10 N1210-S M12			
D5860	  N1110-S M3, M4, M5, M6, M8, M10 N1210-S M12   FO DIN 338 D2.5, 3.3, 4.2, 5.0, 6.8, FO DIN 338 8.5, 10.2			
D5891	  N310-3 M3, M4, M5, M6, M8, M10 N410-3 M12			
No D5855 / D5860 / D5891		ID	ID	ID
M3 - M12		118728	118733	170922
Boxset		D5892		
D5892	   N320V-4 M3, M4, M5, M6, M8, M10 			
No D5892			ID	
M3 - M10			170921	
Boxset		D5896		
D5896	   N360V-3 M3, M4, M5, M6, M8, M10 			
No D5896			ID	
M3 - M10			167599	



Schneideisenhalter und Windeisen

Die stocks and tap wrenches

D5810- Schneideisenhalter für runde Schneideisen nach DIN EN 22568, DIN EN 24230, DIN EN 24231, DIN EN 40434. Die stocks for round dies to DIN EN 22568, DIN EN 24230, DIN EN 24231, DIN EN 40434.									D5810-	D5820-
D5820- Windeisen verstellbar DIN 1814 Tap wrenches, adjustable DIN 1814										
DIN EN	M	MF	UNC	UNF	UNEF UNS UN	W	G (BSP)	NPT NPTF R (BSPT)	ID	
No D5810- Ø	Ø	Ø	Ø	Ø	Ø	Ø	Ø	Ø		
1	16 x 5	1 - 2.6	2 - 2.6	No 1 - 4	No 1 - 4		1/16" - 3/32"		170712	
2	20 x 5	3 - 4	3 - 6	No 5	No 5 - 6		1/8"		170713	
3	20 x 7	4.5 - 6		No 6 - 1/4"	No 8 - 1/4"	No 12 - 1/4"	5/32" - 1/4"		170714	
4	25 x 9	7 - 9	7 - 9	5/16"	5/16"	5/16"	5/16"	1/16"	170715	
5	30 x 11	10 - 11	10 - 11	3/8" - 7/16"	3/8" - 7/16"	3/8" - 7/16"	3/8" - 7/16"	1/8"	170716	
6	38 x 10		12 - 15		1/2" - 9/16"	1/2" - 9/16"		1/4"	170717	
7	38 x 14	12 - 14		1/2" - 9/16"			1/2" - 9/16"	1/4"	170718	
8	45 x 14		16 - 20		5/8" - 3/4"	5/8" - 13/16"		3/8" - 1/2"	170719	
9	45 x 18	16 - 20		5/8" - 3/4"			5/8" - 3/4"	1/2"	170720	
10	55 x 16		22 - 26		7/8" - 1"	7/8" - 1"		5/8" - 3/4"	170721	
11	55 x 22	22 - 24		7/8" - 1"			7/8" - 1"	3/4"	170722	
12	65 x 18		*27 - 36		1 1/8" - 1 3/8"	1 1/16" - 1 3/8"		7/8" - 1"	170723	
13	65 x 25	27 - 36		1 1/8" - 1 3/8"			1 1/8" - 1 3/8"	1"	170724	
14	75 x 20		38 - 42		1 1/2"	1 7/16" - 1 1/2"		1 1/8" - 1 1/4"	170725	
15	75 x 30	39 - 42		1 1/2"			1 1/2" - 1 5/8"		170726	
16	90 x 22		45 - 52			1 3/4" - 2"		1 3/8" - 1 3/4"	170727	
17	90 x 36	45 - 52		1 3/4" - 2"			1 3/4" - 2"		170728	
18	105 x 22		55 - 65					2" - 2 1/4"	170729	
* Ausnahme Steigung 3 mm (Nr. 13 verlangen). For 3 mm pitches use No. 13.										
No D5820-	a mm								ID	
0	1.9 - 3.0								170730	
1	2.5 - 5.5								170731	
2	4.3 - 8.0								170732	
3	5.5 - 12.0								170733	
4	9.5 - 15.5								170734	
5	12.5 - 22.4								170735	

Verlängerungen

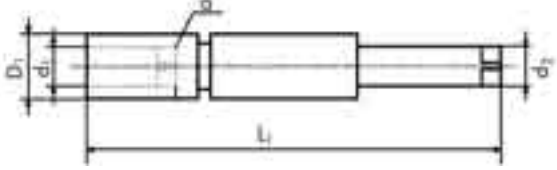
Tap extension sleeves

D5830- Verlängerungen für Gewindebohrer, ~DIN 377. Tap extension sleeves ~DIN 377.		D5840- Verlängerungen für Gewindebohrer. Tap extension sleeves.		D5830-	D5840-		
							
No	a	L ₁	D ₁	ID			
D5830-	mm	mm	mm				
1	2.10	60	6	110571			
2	2.24	70	6	110572			
3	2.40	70	6	110573			
4	2.50	80	7	110574			
5	2.80	90	7	110575			
6	3.00	90	7	110579			
7	3.15	95	7	110580			
8	3.40	95	8	110581			
9	3.55	100	8	118706			
10	3.80	100	9	118707			
11	4.00	105	10	118708			
12	4.30	105	10	118709			
13	4.50	105	10	118710			
14	4.90	110	10	118711			
15	5.00	110	11	118712			
16	5.50	115	12	118713			
17	5.60	110	12	118714			
18	6.20	120	14	118715			
19	6.30	120	14	118716			
20	7.00	125	15	118717			
21	7.10	120	15	118718			
22	7.50	120	15	118719			
23	8.00	125	17	118720			
24	9.00	130	19	118721			
25	10.00	140	21	110562			
26	11.00	150	23	110563			
27	11.20	145	23	110564			
28	12.00	155	25	110565			
29	12.50	160	25	110566			
30	14.00	165	28	110567			
31	14.50	175	29	110568			
32	16.00	180	30	110569			
33	18.00	200	33	110570			
34	20.00	220	36	110576			
35	22.00	220	40	110577			
36	22.40	240	40	110578			
No	a	L ₁	d ₂	d ₁	D ₁	ID	
D5840-	mm	mm	mm	mm	mm		
10	2.70	130	6	3.5	7.5	169928	
11	3.40	130	6	4.5	8.5	169929	
1	4.90	130	6	6.0	12.0	142137	
2	5.50	130	7	7.0	13.0	142138	
3	6.20	130	8	8.0	13.0	142139	
4	7.00	130	9	9.0	17.0	142140	
5	8.00	130	10	10.0	17.0	142141	
6	9.00	130	11	11.0	17.0	142142	
7	9.00	130	12	12.0	20.0	142143	
8	11.00	130	14	14.0	20.0	142144	
9	12.00	130	16	16.0	25.0	142145	

HÄRTEVERGLEICHSTABELLE - HARDNESS CHART

HRC <i>Rockwellhärte</i> Hardness Rockwell	HB <i>Brinellhärte</i> Hardness Brinell	HV <i>Vickershärte</i> Hardness Vickers	N/mm² Mpa <i>Zugfestigkeit</i> Tensile strength
25	253	266	854
26	254	273	873
27	265	279	897
28	272	286	914
29	274	294	944
30	287	302	970
31	295	310	995
32	302	318	1024
33	311	327	1052
34	320	336	1082
35	329	345	1111
36	337	355	1139
37	346	364	1168
38	354	373	1198
39	363	382	1227
40	373	392	1262
41	382	402	1296
42	392	412	1327
43	402	423	1362
44	413	434	1401
45	424	446	1442
46	436	459	1481
47	448	471	1524
48	460	484	1572
49	474	499	1625
50	488	513	1668
51	502	528	1733
52	518	545	1793
53	532	560	1845
54	548	578	1912
55	566	596	1979
56	585	615	2050
57	603	634	2121
58		654	
59		675	
60		698	

Umrechnungstabelle für Härtewerte, Auszug aus DIN 50150
 Conversion chart for hardness values, according to DIN 50150

ZOLL-MM - INCHES-MM

Ø" d ₁	Ø mm	TPI UN											W(BSW)	BSF	G (BSP) R _p	Ø mm			
		UNC	UNF	UNEF	4	6	8	12	16	20	28	32							
0 1/16"	1.52 1.59		80											48		28	7.72		
1 2 3/32"	1.85 2.18 2.38	64 56	72 64																
3 4 5 1/8"	2.51 2.84 3.17 3.17 3.50	48 40 40 32	56 48 44 40											40		28	9.72		
5/32" 8 3/16" 10 12	3.96 4.16 4.76 4.82 5.48	32 32 24 24	36 32 28											32 24	32				
7/32" 1/4" 9/32" 5/16" 3/8"	5.55 6.35 7.14 7.93 9.52	20 18 16	28 24 24	32 32										24 20 16	28 26 20	19 19	13.15 16.66		
7/16" 1/2" 9/16" 5/8" 11/16"	11.11 12.70 14.28 15.87 17.46	14 13 12 11	20 20 18 18	28 28 24 24 24					16 16 16 12 12					32 32 32 28 28	14 12 12 11 14	18 16 16 14	14 14	20.95 22.91	
3/4" 13/16" 7/8" 15/16" 1"	19.05 20.64 22.22 23.81 25.40	10 9 8	16 14 12	20 20 20 20				12 12 12						28 28 28 28	32 32 32	10 9 8	12 12 11	14 14 11	26.44 30.20 33.24
1 1/16" 1 1/8" 1 3/16" 1 1/4" 1 5/16"	26.99 28.57 30.16 31.75 33.34	7 7	12 12	18 18 18 18			8 8 8	12 12 12	16 16 16	20 20 20	28 28 28			7 7	9 9	11 11	37.89 41.91		
1 3/8" 1 7/16" 1 1/2" 1 9/16" 1 5/8"	34.92 36.51 38.10 39.69 41.28	6 6	12 12	18 18 18 18		6 6	8 8 8	12 12	16 16 16	20 20 20	28 28			6 6 5	8 8	11 11	44.32 47.80		
1 11/16" 1 3/4" 1 13/16" 1 7/8" 1 15/16"	42.86 44.45 46.04 47.63 49.21	5		18		6 6 6 6	8 8 8	12 12 12	16 16 16	20 20 20				5 4 1/2	7	11	53.74		
2" 2 1/8" 2 1/4" 2 3/8" 2 1/2"	50.80 53.97 57.15 60.32 63.50	4 1/2 4 1/2 4				6 6 6 6	8 8 8	12 12 12	16 16 16	20 20 20				4 1/2 4 4	7 6 6	11 11 11	59.61 65.71 75.18		
2 5/8" 2 3/4" 2 7/8" 3" 3 1/8"	66.67 69.85 73.02 76.20 79.37	4 4			4 4	6 6 6	8 8 8	12 12 12	16 16 16	20 20 20				3 1/2 3 1/2	6 5	11 11	81.53 87.88		
3 1/4" 3 3/8" 3 1/2" 3 5/8" 3 3/4"	82.55 85.72 88.90 92.07 95.25	4 4 4			4 4	6 6 6	8 8 8	12 12	16 16					3 1/4 3 1/4 3	5 4 1/2 4 1/2	11 11 11	93.98 100.33 106.68		
3 7/8" 4"	98.42 101.60	4			4	6 6	8 8	12 12	16 16					3 3	4 1/2	11	113.03		



UMRECHNUNGSTABELLE - CONVERSION TABLE

	Vc m/min															
	1	2	3	4	5	6	8	10	12	15	20	25	30	40	50	60
	min ⁻¹															
1	318	637	955	1273	1592	1910	2546	3183	3820	4775	6366	7958	9549	12732	15915	19099
2	159	318	477	637	796	955	1273	1592	1910	2387	3183	3979	4775	6366	7958	9549
3	106	212	318	424	531	637	849	1061	1273	1592	2122	2653	3183	4244	5305	6366
4	80	159	239	318	398	477	637	796	955	1194	1592	1989	2387	3183	3979	4775
5	64	127	191	255	318	382	509	637	764	955	1273	1592	1910	2546	3183	3820
6	53	106	159	212	265	318	424	531	637	796	1061	1326	1592	2122	2653	3183
8	40	80	119	159	199	239	318	398	477	597	796	995	1194	1592	1989	2387
10	32	64	95	127	159	191	255	318	382	477	637	796	955	1273	1592	1910
12	27	53	80	106	133	159	212	265	318	398	531	663	796	1061	1326	1592
14	23	45	68	91	114	136	182	227	273	341	455	568	682	909	1137	1364
16	20	40	60	80	99	119	159	199	239	298	398	497	597	796	995	1194
18	18	35	53	71	88	106	141	177	212	265	354	442	531	707	884	1061
20	16	32	48	64	80	95	127	159	191	239	318	398	477	637	796	955
25	13	25	38	51	64	76	102	127	153	191	255	318	382	509	637	764
30	11	21	32	42	53	64	85	106	127	159	212	265	318	424	531	637
35	9	18	27	36	45	55	73	91	109	136	182	227	273	364	455	546
40	8	16	24	32	40	48	64	80	95	119	159	199	239	318	398	477
45	7	14	21	28	35	42	57	71	85	106	141	177	212	283	354	424
50	6	13	19	25	32	38	51	64	76	95	127	159	191	255	318	382

KERNLOCHBOHRUNGEN - CORE HOLES

M DIN 13, ISO 261, *5H / 6H

Ø	P	Kern-Ø Mutter - Core Ø nut			
		Ø mini	Ø maxi	Ø guide line	
d ₁	mm				
* 1	0.25	0.729	0.785	0.75	
* 1.1	0.25	0.829	0.885	0.85	
* 1.2	0.25	0.929	0.985	0.95	
* 1.4	0.30	1.075	1.142	1.10	
1.6	0.35	1.221	1.321	1.25	
1.7	0.35	1.321	1.421	1.35	
1.8	0.35	1.421	1.521	1.45	
2	0.40	1.567	1.679	1.60	
2.2	0.45	1.713	1.838	1.75	
2.3	0.40	1.867	1.979	1.90	
2.5	0.45	2.013	2.138	2.05	
2.6	0.45	2.113	2.238	2.15	
3	0.50	2.459	2.599	2.50	
3.5	0.60	2.850	3.010	2.90	
4	0.70	3.242	3.422	3.30	
4.5	0.75	3.688	3.878	3.75	
5	0.80	4.134	4.334	4.20	
6	1.00	4.917	5.153	5.00	
7	1.00	5.917	6.153	6.00	
8	1.25	6.647	6.912	6.80	
9	1.25	7.647	7.912	7.80	
10	1.50	8.376	8.676	8.50	
11	1.50	9.376	9.676	9.50	
12	1.75	10.106	10.441	10.20	
14	2.00	11.835	12.210	12.00	
16	2.00	13.835	14.210	14.00	
18	2.50	15.294	15.744	15.50	
20	2.50	17.294	17.744	17.50	
22	2.50	19.294	19.744	19.50	
24	3.00	20.752	21.252	21.00	
27	3.00	23.752	24.252	24.00	
30	3.50	26.211	26.771	26.50	
33	3.50	29.211	29.771	29.50	
36	4.00	31.670	32.270	32.00	
39	4.00	34.670	35.270	35.00	
42	4.50	37.129	37.799	37.50	
45	4.50	40.129	40.799	40.50	
48	5.00	42.587	43.297	43.00	
52	5.00	46.587	47.297	47.00	
56	5.50	50.046	50.796	50.50	

MF DIN 13, ISO 261, 6H

Ø	P	Kern-Ø Mutter - Core Ø nut			
		Ø mini	Ø maxi	Ø guide line	
d ₁	mm				
8	1.00	6.917	7.153	7.00	
9	0.75	8.188	8.378	8.25	
9	1.00	7.917	8.153	8.00	
10	0.75	9.188	9.378	9.25	
10	1.00	8.917	9.153	9.00	
10	1.25	8.647	8.912	8.80	
11	0.75	10.188	10.378	10.25	
11	1.00	9.917	10.153	10.00	
12	1.00	10.917	11.153	11.00	
12	1.25	10.647	10.912	10.80	
12	1.50	10.376	10.676	10.50	
14	1.00	12.917	13.153	13.00	
14	1.25	12.647	12.912	12.80	
14	1.50	12.376	12.676	12.50	
15	1.00	13.917	14.153	14.00	
15	1.50	13.376	13.676	13.50	
16	1.00	14.917	15.153	15.00	
16	1.50	14.376	14.676	14.50	
17	1.00	15.917	16.153	16.00	
17	1.50	15.376	15.676	15.50	
18	1.00	16.917	17.153	17.00	
18	1.50	16.376	16.676	16.50	
18	2.00	15.835	16.210	16.00	
20	1.00	18.917	19.153	19.00	
20	1.50	18.376	18.676	18.50	
20	2.00	17.835	18.210	18.00	
22	1.00	20.917	21.153	21.00	
22	1.50	20.376	20.676	20.50	
22	2.00	19.835	20.210	20.00	
24	1.00	22.917	23.153	23.00	
24	1.50	22.376	22.676	22.50	
24	2.00	21.835	22.210	22.00	
25	1.00	23.917	24.153	24.00	
25	1.50	23.376	23.676	23.50	
25	2.00	22.835	23.210	23.00	
27	1.50	25.376	25.676	25.50	
27	2.00	24.835	25.210	25.00	
28	1.00	26.917	27.153	27.00	
28	1.50	26.376	26.676	26.50	
28	2.00	25.835	26.210	26.00	
30	1.00	28.917	29.153	29.00	
30	1.50	28.376	28.676	28.50	
30	2.00	27.835	28.210	28.00	
32	1.50	30.376	30.676	30.50	
32	2.00	29.835	30.210	30.00	
33	1.50	31.376	31.676	31.50	
33	2.00	30.835	31.210	31.00	
35	1.50	33.376	33.676	33.50	
36	1.50	34.376	34.676	34.50	
36	2.00	33.835	34.210	34.00	
36	3.00	32.752	33.252	33.00	
39	1.50	37.376	37.676	37.50	
39	2.00	36.835	37.210	37.00	
39	3.00	35.752	36.252	36.00	
40	1.50	38.376	38.676	38.50	

MF DIN 13, ISO 261, 6H

Ø	P	Kern-Ø Mutter - Core Ø nut			
		Ø mini	Ø maxi	Ø guide line	
d ₁	mm				
2.5	0.35	2.121	2.221	2.15	
3	0.35	2.621	2.721	2.65	
3.5	0.35	3.121	3.221	3.15	
4	0.50	3.459	3.599	3.50	
4.5	0.50	3.959	4.099	4.00	
5	0.50	4.459	4.599	4.50	
5.5	0.50	4.959	5.099	5.00	
6	0.75	5.188	5.378	5.25	
7	0.75	6.188	6.378	6.25	
8	0.75	7.188	7.378	7.25	



KERNLOCHBOHRUNGEN - CORE HOLES

MF DIN 13, ISO 261, 6H

Ø	P	Kern-Ø Mutter - Core Ø nut			
		Ø mini	Ø maxi	Ø guide line	
d ₁	mm				
40	2.00	37.835	38.210	38.00	
40	3.00	36.752	37.252	37.00	
42	1.50	40.376	40.676	40.50	
42	2.00	39.835	40.210	40.00	
42	3.00	38.752	39.252	39.00	
45	1.50	43.376	43.676	43.50	
45	2.00	42.835	43.210	43.00	
45	3.00	41.752	42.252	42.00	
48	1.50	46.376	46.676	46.50	
48	2.00	45.835	46.210	46.00	
48	3.00	44.752	45.252	45.00	
50	1.50	48.376	48.676	48.50	
50	2.00	47.835	48.210	48.00	
50	3.00	46.752	47.252	47.00	
52	1.50	50.376	50.676	50.50	
52	2.00	49.835	50.210	50.00	
52	3.00	48.752	49.252	49.00	
55	2.00	52.835	53.210	53.00	
60	2.00	57.835	58.210	58.00	

MF EN 60423:1994, 7H

Ø	P	Kern-Ø Mutter - Core Ø nut			
		Ø mini	Ø maxi	Ø guide line	
d ₁	mm				
8	1.00	6.917	7.217	7.00	
10	1.00	8.917	9.217	9.00	
12	1.50	10.376	10.751	10.50	
16	1.50	14.376	14.751	14.50	
20	1.50	18.376	18.751	18.50	
25	1.50	23.376	23.751	23.50	
32	1.50	30.376	30.751	30.50	
40	1.50	38.376	38.751	38.50	
63	1.50	61.376	61.751	61.50	

UNC ANSI B1.1, 2B

Ø"	P	P	Kern-Ø Mutter - Core Ø nut			
			Ø mini	Ø maxi	Ø guide line	
d ₁	TPI	mm				
1	64	0.397	1.425	1.582	1.45	
2	56	0.454	1.695	1.871	1.75	
3	48	0.529	1.941	2.146	2.00	
4	40	0.635	2.157	2.385	2.25	
5	40	0.635	2.487	2.697	2.55	
6	32	0.794	2.642	2.895	2.75	
8	32	0.794	3.302	3.530	3.40	
10	24	1.058	3.683	3.962	3.80	
12	24	1.058	4.344	4.597	4.40	
1/4"	20	1.270	4.979	5.257	5.10	
5/16"	18	1.411	6.401	6.731	6.50	

UNC ANSI B1.1, 2B

Ø"	P	P	Kern-Ø Mutter - Core Ø nut			
			Ø mini	Ø maxi	Ø guide line	
d ₁	TPI	mm				
3/8"	16	1.588	7.798	8.153	8.00	
7/16"	14	1.814	9.144	9.550	9.30	
1/2"	13	1.954	10.592	11.023	10.80	
9/16"	12	2.117	11.989	12.446	12.20	
5/8"	11	2.309	13.386	13.868	13.60	
3/4"	10	2.540	16.307	16.840	16.60	
7/8"	9	2.822	19.177	19.761	19.50	
1"	8	3.175	21.971	22.606	22.30	
1 1/8"	7	3.629	24.638	25.349	25.00	
1 1/4"	7	3.629	27.813	28.524	28.20	
1 3/8"	6	4.233	30.353	31.115	30.80	
1 1/2"	6	4.233	33.528	34.290	34.00	
1 3/4"	5	5.080	38.964	39.827	39.50	
2"	4.5	5.644	44.679	45.593	45.30	

UNJC ISO 3161:1999, 3B

Ø"	P	P	Kern-Ø Mutter - Core Ø nut			
			Ø mini	Ø maxi	Ø guide line	
d ₁	TPI	mm				
4	40	0.635	2.228	2.393	2.30	
5	40	0.635	2.558	2.723	2.60	
6	32	0.794	2.733	2.939	2.80	
8	32	0.794	3.393	3.599	3.45	
10	24	1.058	3.795	4.064	3.90	
12	24	1.058	4.455	4.704	4.55	
1/4"	20	1.270	5.113	5.387	5.20	
5/16"	18	1.411	6.563	6.833	6.70	
3/8"	16	1.588	7.978	8.255	8.10	
7/16"	14	1.814	9.347	9.639	9.40	
1/2"	13	1.954	10.798	11.095	10.90	
9/16"	12	2.117	12.228	12.482	12.40	
5/8"	11	2.309	13.627	13.904	13.80	
3/4"	10	2.540	16.576	16.881	16.70	

KERNLOCHBOHRUNGEN - CORE HOLES

UNF ANSI B1.1, 2B

Ø"	P	P	Kern-Ø Mutter - Core Ø nut		
d _i	TPI	mm	Ø mini	Ø maxi	Ø guide line
0	80	0.318	1.182	1.305	1.20
1	72	0.353	1.474	1.612	1.50
2	64	0.397	1.756	1.912	1.80
3	56	0.454	2.025	2.197	2.10
4	48	0.529	2.271	2.458	2.35
5	44	0.577	2.551	2.740	2.60
6	40	0.635	2.820	3.022	2.90
8	36	0.706	3.404	3.606	3.50
10	32	0.794	3.963	4.165	4.05
12	28	0.907	4.496	4.724	4.60
1/4"	28	0.907	5.360	5.588	5.50
5/16"	24	1.058	6.782	7.035	6.90
3/8"	24	1.058	8.382	8.636	8.50
7/16"	20	1.270	9.729	10.033	9.80
1/2"	20	1.270	11.329	11.607	11.40
9/16"	18	1.411	12.751	13.081	12.90
5/8"	18	1.411	14.351	14.681	14.50
3/4"	16	1.588	17.323	17.678	17.50
7/8"	14	1.814	20.270	20.675	20.40
1"	12	2.117	23.114	23.571	23.30
1 1/8"	12	2.117	26.289	26.746	26.50
1 1/4"	12	2.117	29.464	29.921	29.70
1 3/8"	12	2.117	32.639	33.096	32.80
1 1/2"	12	2.117	35.814	36.271	36.00

UNEF ANSI B1.1, 2B

Ø"	P	P	Kern-Ø Mutter - Core Ø nut		
d _i	TPI	mm	Ø mini	Ø maxi	Ø guide line
12	32	0.794	4.623	4.826	4.70
1/4"	32	0.794	5.487	5.689	5.60
5/16"	32	0.794	7.087	7.264	7.20
3/8"	32	0.794	8.662	8.864	8.75
7/16"	28	0.907	10.135	10.337	10.25
1/2"	28	0.907	11.710	11.938	11.85
9/16"	24	1.058	13.132	13.385	13.20
5/8"	24	1.058	14.732	14.986	14.80
11/16"	24	1.058	16.307	16.560	16.40
3/4"	20	1.270	17.679	17.957	17.80
13/16"	20	1.270	19.254	19.558	19.40
7/8"	20	1.270	20.854	21.132	21.00
1"	20	1.270	24.029	24.307	24.10

UN ANSI B1.1, 2B

Ø"	P	P	Kern-Ø Mutter - Core Ø nut		
d _i	TPI	mm	Ø mini	Ø maxi	Ø guide line
5/16"	20	1.270	6.554	6.858	6.70
3/8"	20	1.270	8.154	8.432	8.30
9/16"	20	1.270	12.904	13.208	13.00
5/8"	20	1.270	14.504	14.782	14.60
1 1/8"	8	3.175	25.146	25.781	25.50
1 1/4"	8	3.175	28.321	28.956	28.70
1 3/8"	8	3.175	31.496	32.131	31.80
1 1/2"	8	3.175	34.671	35.306	35.00
1 5/8"	8	3.175	37.846	38.481	38.20
1 3/4"	8	3.175	41.021	41.656	41.40
1 7/8"	8	3.175	44.196	44.831	44.50
2"	8	3.175	47.371	48.006	47.70
2 1/4"	8	3.175	53.721	54.356	54.10
2 1/2"	8	3.175	60.071	60.706	60.40

UNJF ISO 3161:1999, 3B

Ø"	P	P	Kern-Ø Mutter - Core Ø nut		
d _i	TPI	mm	Ø mini	Ø maxi	Ø guide line
0	80	0.318	1.217	1.298	1.25
1	72	0.353	1.511	1.603	1.55
2	64	0.397	1.798	1.902	1.85
3	56	0.454	2.073	2.189	2.15
4	48	0.529	2.329	2.466	2.35
5	44	0.577	2.614	2.764	2.70
6	40	0.635	2.888	3.053	2.95
8	36	0.706	3.480	3.663	3.60
10	32	0.794	4.054	4.255	4.10
12	28	0.907	4.602	4.816	4.70
1/4"	28	0.907	5.466	5.662	5.55
5/16"	24	1.058	6.906	7.109	7.00
3/8"	24	1.058	8.494	8.679	8.60
7/16"	20	1.270	9.876	10.084	10.00
1/2"	20	1.270	11.463	11.661	11.55
9/16"	18	1.411	12.913	13.122	13.05
5/8"	18	1.411	14.501	14.702	14.60
3/4"	16	1.588	17.506	17.722	17.60
7/8"	14	1.814	20.460	20.706	20.50
1"	12	2.117	23.340	23.594	23.40



KERNLOCHBOHRUNGEN - CORE HOLES

UNS ANSI B1.1, 2B

Ø"	P	P	Kern-Ø Mutter - Core Ø nut		
d _i	TPI	mm	Ø mini	Ø maxi	Ø guide line
10	36	0.706	4.064	4.216	4.10
10	40	0.635	4.141	4.292	4.20
10	56	0.454	4.344	4.445	4.40
1/4"	36	0.706	5.588	5.740	5.65
1/4"	40	0.635	5.665	5.816	5.70
1/4"	48	0.529	5.766	5.892	5.80
1/4"	56	0.454	5.868	5.969	5.90
5/16"	36	0.706	7.163	7.340	7.25
3/8"	36	0.706	8.763	8.940	8.80
7/16"	24	1.058	9.957	10.210	10.00
1/2"	24	1.058	11.557	11.811	11.60
1"	14	1.814	23.445	23.825	23.60

W (BSW) BS 84, (DIN11 - 1970)

Ø"	P	P	Kern-Ø Mutter - Core Ø nut		
d _i	TPI	mm	Ø mini	Ø maxi	Ø guide line
(3/32")	48				1.80
1/8"	40	0.635	2.362	2.591	2.50
(5/32")	32				3.10
3/16"	24	1.058	3.406	3.744	3.60
(7/32")	24				4.40
1/4"	20	1.270	4.724	5.156	4.90
5/16"	18	1.411	6.129	6.588	6.40
3/8"	16	1.588	7.493	7.988	7.70
7/16"	14	1.814	8.791	9.332	9.10
1/2"	12	2.117	9.987	10.589	10.30
5/8"	11	2.309	12.918	13.558	13.30
3/4"	10	2.540	15.799	16.484	16.20
7/8"	9	2.822	18.613	19.355	19.25
1"	8	3.175	21.336	22.149	21.90

G (BSP) DIN ISO 228

Ø"	P	P	Kern-Ø Mutter - Core Ø nut		
d _i	TPI	mm	Ø mini	Ø maxi	Ø guide line
1/16"	28	0.907	6.561	6.843	6.75
1/8"	28	0.907	8.566	8.848	8.75
1/4"	19	1.337	11.445	11.890	11.60
3/8"	19	1.337	14.950	15.395	15.20
1/2"	14	1.814	18.631	19.172	18.90
5/8"	14	1.814	20.587	21.128	20.90
3/4"	14	1.814	24.117	24.658	24.40
7/8"	14	1.814	27.877	28.418	28.20
1"	11	2.309	30.291	30.931	30.70
1 1/8"	11	2.309	34.939	35.579	35.30
1 1/4"	11	2.309	38.952	39.592	39.30
1 3/8"	11	2.309	41.365	42.005	41.80
1 1/2"	11	2.309	44.845	45.485	45.20
1 3/4"	11	2.309	50.788	51.428	51.20
2"	11	2.309	56.656	57.296	57.00
2 1/4"	11	2.309	62.752	63.392	63.10
2 1/2"	11	2.309	72.226	72.866	72.60
3"	11	2.309	84.926	85.566	85.30

PG DIN 40430

Ø	P	P	Kern-Ø Mutter - Core Ø nut		
d _i	TPI	mm	Ø mini	Ø maxi	Ø guide line
7	20	1.270	11.28	11.43	11.35
9	18	1.411	13.86	14.01	13.90
11	18	1.411	17.26	17.41	17.30
13.5	18	1.411	19.06	19.21	19.10
16	18	1.411	21.16	21.31	21.20
21	16	1.588	26.78	27.03	26.80
29	16	1.588	35.48	35.73	35.50
36	16	1.588	45.48	45.73	45.50
42	16	1.588	52.48	52.73	52.50
48	16	1.588	57.78	58.03	57.80

TR ISO 2901-2904, DIN 103, 7H

Ø	P	Kern-Ø Mutter - Core Ø nut		
d _i	mm	Ø mini	Ø maxi	Ø guide line
10	2	8	8.236	8.20
12	3	9	9.315	9.25
14	3	11	11.315	11.25
16	4	12	12.375	12.25
18	4	14	14.375	14.25
20	4	16	16.375	16.25
22	5	17	17.450	17.25
24	5	19	19.450	19.25
26	5	21	21.450	21.25
28	5	23	23.450	23.25
30	6	24	24.500	24.25
32	6	26	26.500	26.25

AUSSENDURCHMESSER - TURNED DIAMETERS

M DIN 13, ISO 261, *6h / 6g

Ø	P	Aussen-Ø Bolzen - Thread outside Ø		
		Ø mini	Ø maxi	Ø guide line
d ₁	mm			
* 1	0.25	0.933	1.000	0.97
* 1.1	0.25	1.033	1.100	1.07
* 1.2	0.25	1.133	1.200	1.17
* 1.4	0.30	1.325	1.400	1.36
1.6	0.35	1.496	1.581	1.54
1.7	0.35	1.596	1.681	1.64
1.8	0.35	1.696	1.781	1.74
2	0.40	1.886	1.981	1.93
2.2	0.45	2.080	2.180	2.13
2.3	0.40	2.186	2.300	2.23
2.5	0.45	2.380	2.480	2.43
2.6	0.45	2.480	2.600	2.53
3	0.50	2.874	2.980	2.92
3.5	0.60	3.354	3.479	3.41
4	0.70	3.838	3.978	3.91
4.5	0.75	4.338	4.478	4.40
5	0.80	4.826	4.976	4.90
6	1.00	5.794	5.974	5.88
7	1.00	6.794	6.974	6.88
8	1.25	7.760	7.972	7.87
9	1.25	8.760	8.972	8.87
10	1.50	9.732	9.968	9.85
11	1.50	10.732	10.968	10.85
12	1.75	11.701	11.966	11.83
14	2.00	13.682	13.962	13.82
16	2.00	15.682	15.962	15.82
18	2.50	17.623	17.958	17.79
20	2.50	19.623	19.958	19.79
22	2.50	21.623	21.958	21.79
24	3.00	23.577	23.952	23.76
27	3.00	26.577	26.952	26.76
30	3.50	29.522	29.947	29.73
33	3.50	32.522	32.947	32.73
36	4.00	35.465	35.940	35.70
39	4.00	38.465	38.940	38.70
42	4.50	41.437	41.937	41.69
45	4.50	44.437	44.937	44.69
48	5.00	47.399	47.929	47.66
52	5.00	51.399	51.929	51.66
56	5.50	55.365	55.925	55.65

MF DIN 13, ISO 261, 6g

Ø	P	Aussen-Ø Bolzen - Thread outside Ø		
		Ø mini	Ø maxi	Ø guide line
d ₁	mm			
8	1.00	7.794	7.974	7.88
9	0.75	8.838	8.978	8.90
9	1.00	8.794	8.974	8.88
10	0.75	9.838	9.978	9.90
10	1.00	9.794	9.974	9.88
10	1.25	9.760	9.972	9.86
11	0.75	10.838	10.978	10.90
11	1.00	10.794	10.974	10.88
12	1.00	11.794	11.974	11.88
12	1.25	11.760	11.972	11.86
14	1.00	13.794	13.974	13.88
14	1.25	13.760	13.972	13.86
14	1.50	13.732	13.968	13.85
15	1.00	14.794	14.974	14.88
15	1.50	14.732	14.968	14.85
16	1.00	15.794	15.974	15.88
16	1.50	15.732	15.968	15.85
17	1.00	16.794	16.974	16.88
17	1.50	16.732	16.968	16.85
18	1.00	17.794	17.974	17.88
18	1.50	17.732	17.968	17.85
18	2.00	17.682	17.962	17.82
20	1.00	19.794	19.974	19.88
20	1.50	19.732	19.968	19.85
20	2.00	19.682	19.962	19.82
22	1.00	21.794	21.974	21.88
22	1.50	21.732	21.968	21.85
22	2.00	21.682	21.962	21.82
24	1.00	23.794	23.974	23.88
24	1.50	23.732	23.968	23.85
24	2.00	23.682	23.962	23.82
25	1.00	24.794	24.974	24.88
25	1.50	24.732	24.968	24.85
25	2.00	24.682	24.962	24.82
27	1.00	26.794	26.974	26.88
27	1.50	26.732	26.968	26.85
27	2.00	26.682	26.962	26.82
28	1.00	27.794	27.974	27.88
28	1.50	27.732	27.968	27.85
28	2.00	27.682	27.962	27.82
30	1.00	29.794	29.974	29.88
30	1.50	29.732	29.968	29.85
30	2.00	29.682	29.962	29.82
30	3.00	29.577	29.952	29.76
32	1.50	31.732	31.968	31.85
32	2.00	31.682	31.962	31.82
33	1.50	32.732	32.968	32.85
33	2.00	32.682	32.962	32.82
33	3.00	32.577	32.952	32.76
35	1.50	34.732	34.968	34.85
36	1.50	35.732	35.968	35.85
36	2.00	35.682	35.962	35.82
36	3.00	35.577	35.952	35.76
39	1.50	38.732	38.968	38.85
39	2.00	38.682	38.962	38.82
39	3.00	38.577	38.952	38.76

MF DIN 13, ISO 261, 6g

Ø	P	Aussen-Ø Bolzen - Thread outside Ø		
		Ø mini	Ø maxi	Ø guide line
d ₁	mm			
2.5	0.35	2.396	2.481	2.44
3	0.35	2.896	2.981	2.94
3.5	0.35	3.396	3.481	3.44
4	0.50	3.874	3.980	3.93
4.5	0.50	4.374	4.480	4.43
5	0.50	4.874	4.980	4.93
5.5	0.50	5.374	5.480	5.43
6	0.75	5.838	5.978	5.90
7	0.75	6.838	6.978	6.90
8	0.75	7.838	7.978	7.90



AUSSENDURCHMESSER - TURNED DIAMETERS

MF DIN 13, ISO 261, 6g

Ø	P	Aussen-Ø Bolzen - Thread outside Ø			
		Ø mini	Ø maxi	Ø guide line	
d _i	mm				
40	1.50	39.732	39.968	39.85	
40	2.00	39.682	39.962	39.82	
40	3.00	39.577	39.952	39.76	
42	1.50	41.732	41.968	41.85	
42	2.00	41.682	41.962	41.82	
42	3.00	41.577	41.952	41.76	
45	1.50	44.732	44.968	44.85	
45	2.00	44.682	44.962	44.82	
45	3.00	44.577	44.952	44.76	
48	1.50	47.732	47.968	47.85	
48	2.00	47.682	47.962	47.82	
48	3.00	47.577	47.952	47.76	
50	1.50	49.732	49.968	49.85	
50	2.00	49.682	49.962	49.82	
50	3.00	49.577	49.952	49.76	
52	1.50	51.732	51.968	51.85	
52	2.00	51.682	51.962	51.82	
52	3.00	51.577	51.952	51.76	
52	4.00	51.465	51.940	51.70	

UNC ANSI B1.1, 2A

Ø"	P	P Aussen-Ø Bolzen - Thread outside Ø			
		mm	Ø mini	Ø maxi	
d _i	TPI				
1	64	0.397	1.743	1.838	1.79
2	56	0.454	2.066	2.169	2.12
3	48	0.529	2.383	2.496	2.44
4	40	0.635	2.695	2.824	2.76
5	40	0.635	3.026	3.154	3.09
6	32	0.794	3.333	3.484	3.41
8	32	0.794	3.991	4.142	4.07
10	24	1.058	4.618	4.800	4.71
12	24	1.058	5.279	5.461	5.37
1/4"	20	1.270	6.117	6.322	6.22
5/16"	18	1.411	7.687	7.907	7.80
3/8"	16	1.588	9.254	9.491	9.37
7/16"	14	1.814	10.816	11.076	10.95
1/2"	13	1.954	12.386	12.661	12.52
9/16"	12	2.117	13.958	14.246	14.10
5/8"	11	2.309	15.528	15.834	15.68
3/4"	10	2.540	18.677	19.004	18.84
7/8"	9	2.822	21.824	22.176	22.00
1"	8	3.175	24.969	25.349	25.16
1 1/8"	7	3.629	28.103	28.519	28.31
1 1/4"	7	3.629	31.278	31.694	31.49
1 3/8"	6	4.233	34.402	34.864	34.63
1 1/2"	6	4.233	37.577	38.039	37.81
1 3/4"	5	5.080	43.860	44.381	44.12
2"	4.5	5.644	50.168	50.726	50.45
2 1/4"	4.5	5.644	56.518	57.076	56.80
2 1/2"	4	6.350	62.817	63.421	63.12
2 3/4"	4	6.350	69.165	69.768	69.47
3"	4	6.350	75.515	76.118	75.82
3 1/4"	4	6.350	81.862	82.466	82.16
3 1/2"	4	6.350	88.212	88.816	88.51

UNC ANSI B1.1, 2A

Ø"	P	P Aussen-Ø Bolzen - Thread outside Ø			
		mm	Ø mini	Ø maxi	
d _i	TPI				
3 3/4"	4	6.350	94.560	95.163	94.86
4"	4	6.350	100.910	101.513	101.21

UNF ANSI B1.1, 2A

Ø"	P	P Aussen-Ø Bolzen - Thread outside Ø			
		mm	Ø mini	Ø maxi	
d _i	TPI				
0	80	0.318	1.431	1.511	1.47
1	72	0.353	1.751	1.838	1.79
2	64	0.397	2.073	2.169	2.12
3	56	0.454	2.393	2.496	2.44
4	48	0.529	2.713	2.827	2.77
5	44	0.577	3.036	3.157	3.10
6	40	0.635	3.356	3.484	3.42
8	36	0.706	4.006	4.145	4.08
10	32	0.794	4.651	4.803	4.73
12	28	0.907	5.296	5.461	5.38
1/4"	28	0.907	6.160	6.324	6.24
5/16"	24	1.058	7.727	7.909	7.82
3/8"	24	1.058	9.315	9.497	9.41
7/16"	20	1.270	10.874	11.079	10.98
1/2"	20	1.270	12.462	12.666	12.56
9/16"	18	1.411	14.031	14.251	14.14
5/8"	18	1.411	15.619	15.839	15.73
3/4"	16	1.588	18.774	19.011	18.89
7/8"	14	1.814	21.923	22.184	22.05
1"	12	2.117	25.065	25.354	25.21
1 1/8"	12	2.117	28.240	28.529	28.38
1 1/4"	12	2.117	31.415	31.704	31.56
1 3/8"	12	2.117	34.588	34.876	34.73
1 1/2"	12	2.117	37.763	38.051	37.91

UNEF ANSI B1.1, 2A

Ø"	P	P Aussen-Ø Bolzen - Thread outside Ø			
		mm	Ø mini	Ø maxi	
d _i	TPI				
12	32	0.794	5.312	5.463	5.39
1/4"	32	0.794	6.173	6.324	6.25
5/16"	32	0.794	7.760	7.912	7.84
3/8"	32	0.794	9.348	9.499	9.42
7/16"	28	0.907	10.920	11.084	11.00
1/2"	28	0.907	12.507	12.672	12.59
9/16"	24	1.058	14.075	14.257	14.17
5/8"	24	1.058	15.662	15.844	15.75
11/16"	24	1.058	17.250	17.432	17.34
3/4"	20	1.270	18.812	19.016	18.91
13/16"	20	1.270	20.339	20.604	20.50
7/8"	20	1.270	21.987	22.191	22.09
15/16"	20	1.270	23.572	23.776	23.67
1"	20	1.270	25.159	25.364	25.26
1 1/8"	18	1.411	28.319	28.539	28.43
1 1/4"	18	1.411	31.491	31.711	31.60
1 1/2"	18	1.411	37.841	38.061	37.95

AUSSENDURCHMESSER - TURNED DIAMETERS

UN ANSI B1.1, 2A

Ø"	P	P Aussen-Ø Bolzen - Thread outside Ø				
		d _i	TPI	mm	Ø mini	
5/16"	20	1.270	7.702	7.907	7.80	
3/8"	20	1.270	9.289	9.494	9.39	
9/16"	20	1.270	14.049	14.254	14.15	
5/8"	20	1.270	15.637	15.841	15.74	
1 1/8"	8	3.175	28.141	28.521	28.33	
1 1/4"	8	3.175	31.316	31.696	31.51	
1 3/8"	8	3.175	34.489	34.869	34.68	
1 1/2"	8	3.175	37.664	38.044	37.85	
1 5/8"	8	3.175	40.839	41.219	41.03	
1 3/4"	8	3.175	44.011	44.391	44.20	
1 7/8"	8	3.175	47.186	47.566	47.38	
2"	8	3.175	50.361	50.741	50.55	
2 1/4"	8	3.175	56.709	57.089	56.90	
2 1/2"	8	3.175	63.059	63.439	63.25	
2 3/4"	8	3.175	69.406	69.786	69.60	
3"	8	3.175	75.753	76.133	75.94	

W (BSW) BS 84

Ø"	P	P Aussen-Ø Bolzen - Thread outside Ø				
		d _i	TPI	mm	Ø mini	
1/4"	20	1.270	6.165	6.319	6.24	
5/16"	18	1.411	7.737	7.904	7.82	
3/8"	16	1.588	9.312	9.489	9.40	
7/16"	14	1.814	10.884	11.074	10.98	
1/2"	12	2.117	12.456	12.662	12.56	
5/8"	11	2.309	15.613	15.832	15.72	
3/4"	10	2.540	18.771	19.004	18.89	
7/8"	9	2.822	21.979	22.225	22.10	
1"	8	3.175	25.138	25.400	25.27	
1 1/8"	7	3.629	28.296	28.575	28.44	
1 1/4"	7	3.629	31.465	31.750	31.61	
1 1/2"	6	4.233	37.793	38.100	37.95	
1 3/4"	5	5.080	44.117	44.450	44.28	
2"	4.5	5.644	50.449	50.800	50.62	
2 1/4"	4	6.350	56.779	57.150	56.96	
2 1/2"	4	6.350	63.119	63.500	63.31	

UNS ANSI B1.1, 2A

Ø"	P	P Aussen-Ø Bolzen - Thread outside Ø				
		d _i	TPI	mm	Ø mini	
10	36	0.706	4.664	4.803	4.73	
10	40	0.635	4.674	4.803	4.74	
10	56	0.454	4.705	4.808	4.76	
1/4"	36	0.706	6.188	6.327	6.26	
1/4"	40	0.635	6.198	6.327	6.26	
1/4"	48	0.529	6.216	6.329	6.27	
1/4"	56	0.454	6.226	6.329	6.28	
5/16"	36	0.706	7.775	7.914	7.84	
3/8"	36	0.706	9.360	9.499	9.43	
7/16"	24	1.058	10.902	11.084	10.99	
1/2"	24	1.058	12.487	12.669	12.58	
1"	14	1.814	25.096	25.356	25.23	

PG DIN 40430

Ø	P	P Aussen-Ø Bolzen - Thread outside Ø				
		d _i	TPI	mm	Ø mini	
7	20	1.270	12.3	12.5	12.40	
9	18	1.411	15.0	15.2	15.10	
11	18	1.411	18.4	18.6	18.50	
13.5	18	1.411	20.2	20.4	20.30	
16	18	1.411	22.3	22.5	22.40	
21	16	1.588	28.0	28.3	28.15	
29	16	1.588	36.7	37.0	36.85	
36	16	1.588	46.7	47.0	46.85	
42	16	1.588	53.7	54.0	53.85	
48	16	1.588	59.0	59.3	59.15	

G (BSP) DIN ISO 228

Ø"	P	P Aussen-Ø Bolzen - Thread outside Ø				
		d _i	TPI	mm	Ø mini	
1/16"	28	0.907	7.509	7.723	7.62	
1/8"	28	0.907	9.514	9.728	9.62	
1/4"	19	1.337	12.907	13.157	13.03	
3/8"	19	1.337	16.412	16.662	16.54	
1/2"	14	1.814	20.671	20.955	20.81	
5/8"	14	1.814	22.627	22.911	22.77	
3/4"	14	1.814	26.157	26.441	26.30	
7/8"	14	1.814	29.917	30.201	30.06	
1"	11	2.309	32.889	33.249	33.07	
1 1/8"	11	2.309	37.537	37.897	37.72	
1 1/4"	11	2.309	41.550	40.910	41.73	
1 3/8"	11	2.309	43.963	44.323	44.14	
1 1/2"	11	2.309	47.443	47.803	47.62	
1 3/4"	11	2.309	53.386	53.746	53.57	
2"	11	2.309	59.254	59.614	59.43	
2 1/4"	11	2.309	65.276	65.710	65.49	
2 1/2"	11	2.309	74.750	75.184	74.97	
2 3/4"	11	2.309	81.100	81.534	81.32	
3"	11	2.309	87.450	87.884	87.67	
3 1/2"	11	2.309	99.896	100.330	100.11	

TR ISO 2901-2904, DIN 103, 7e

Ø	P	Aussen-Ø Bolzen - Thread outside Ø				
		d _i	mm	Ø mini	Ø maxi	
10	2	9.820	10.000	9.91		
12	3	11.764	12.000	11.88		
14	3	13.764	14.000	13.88		
16	4	15.700	16.000	15.85		
18	4	17.700	18.000	17.85		
20	4	19.700	20.000	19.85		
22	5	21.665	22.000	21.83		
24	5	23.665	24.000	23.83		
26	5	25.665	26.000	25.83		
28	5	27.665	28.000	27.83		
30	6	29.625	30.000	29.81		
32	6	31.625	32.000	31.81		



Angebotsanfrage

Versuchsergebnis

Beanstandung

Vertretung : _____
Kunde : _____
Tel.- /Fax-Nr : _____

Kontaktperson : _____
E-Mail : _____
Datum : _____

1. Werkzeug-Typ : _____
Besonderheit : _____

Abmessung : _____
Toleranzklasse : _____

2. Werkstoffgruppe : _____

Werkstoff-Nr : _____
Norm : _____

Härte : _____ N/mm² /HB/HRC
Bruchdehnung : _____ %

3. Gewinde : Sackloch Durchgangsloch

Gewindelänge : _____ mm

Kernloch-Ø : _____

Tiefe : _____ mm

Aufbohrungs-Ø : _____

Tiefe : _____ mm

4. Schnittgeschwindigkeit (V_c) : _____ m/min _____ 1/min

Vorschub (f) : _____ %

5. Maschine : _____

Innenkühlung

Arbeitsrichtung : horizontal

vertikal

Synchro-Gewindeschneiden : Soft-Rigidfutter

Gewindeschneidspindel : Längenausgleich

Spannzange

Ausklinkbar

Weldon

Rutschkupplung

Schrumpffutter

Automat. Umschaltung

6. Schmierung : Emulsion

Schneidöl

Luft

MMS

Produkt : _____

7. Grund des Werkzeugwechsels : Werkzeugverschleiss

Werkzeugbruch

Gewinde nicht korrekt (kontrolliert mit Lehre)

Zahnausbrüche im Anschnittbereich

Maschinenfehler

Zahnausbrüche im Führungsgewinde

8. Standzeitvergleich

Vergleichswerkzeug : _____

Resultat und Befund : _____

Bemerkungen : _____

TECHNICAL QUESTIONNAIRE

THREAD CUTTING AND THREAD FORMING

Enquiry

Test result

Complaint

Agency : _____
Customer : _____
Phone or fax : _____

Contact : _____
E-mail : _____
Date : _____

1. Tool type : _____ Thread size : _____
Particularity : _____ Class of tolerance : _____

2. Material group : _____
Material N° : _____ Hardness : _____ N/mm² /HB/HRC
Norm : _____ Elongation : _____ %

3. Thread : blind hole through hole Threaded length : _____ mm
Core hole Ø : _____ Depth : _____ mm
Counter-bore Ø : _____ Depth : _____ mm

4. Cutting speed (V_c) : _____ m/min _____ l/min
Feed (f) : _____ %

5. Machine : _____ internal coolant
Working position : horizontal vertical
Rigid Tapping : "Soft Rigid Tapping"
 collet de-clutching
 Weldon reversible
 hot / cold shrunk sliding clutch

6. Lubricant : emulsion oil air mist
Product : _____

7. Tool change reason : tool wear tool breakage
 thread not correct (checked with thread plug gauge) tooth breakage in the chamfer lead
 machine error tooth breakage in the guiding thread

8. Efficiency comparison

Tool under test : _____
Performance and observations : _____

Remarks : _____

Angebotsanfrage

Versuchsergebnis

Beanstandung

Vertretung : _____
 Kunde : _____
 Tel.- /Fax-Nr : _____

Kontaktperson : _____
 E-Mail : _____
 Datum : _____

1. Werkzeug-Typ : _____

Nenn-Ø : _____
 Serie : _____

Steigung : _____
 Beschichtung : _____

2. Werkstoffgruppe : _____

Werkstoff-Nr : _____
 Norm : _____

Härte : _____ N/mm² /HB/HRC
 Bruchdehnung : _____ %

3. Gewinde : Innen Aussen

Lochart : Sackloch Durchgangsloch

Gewindelänge : _____ mm

Kernloch-Ø : _____ Tiefe : _____ mm

Aufbohrungs-Ø : _____ Tiefe : _____ mm

4. Schnittgeschwindigkeit (V_c) : _____ m/min _____ 1/min

Vorschub (f) : _____ mm/U

Vorschub (f_z) : _____ mm/Zahn

5. Maschine : _____

Innenkühlung

Arbeitsrichtung : horizontal
vertikal

Werkzeugaufnahme :

Spannzange

Weldon / Whistle Notch

Hydrodehnspannfutter

Schrumpffutter

6. Schmierung : Emulsion

Schneidöl

Luft

MMS

Produkt : _____

7. Grund des Werkzeugwechsels Werkzeugverschleiss

Werkzeugbruch

Gewinde nicht korrekt (kontrolliert mit Lehre)

Maschinenfehler

8. Standzeitvergleich

Vergleichswerkzeug : _____

Resultat und Befund : _____

Bemerkungen : _____

TECHNICAL QUESTIONNAIRE

THREAD MILLING AND THREAD WHIRLING

Enquiry

Test result

Complaint

Agency : _____
Customer : _____
Phone or fax : _____

Contact : _____
E-mail : _____
Date : _____

1. Tool type : _____

Tool Ø : _____
Serie : _____

Pitch : _____
Coating : _____

2. Material group : _____

Material N° : _____
Norm : _____

Hardness : _____ N/mm² /HB/HRC
Elongation : _____ %

3. Thread : internal external

Hole : blind through

Threaded length : _____ mm

Core hole Ø : _____ Depth : _____ mm

Counter-bore Ø : _____ Depth : _____ mm

4. Cutting speed (V_c) : _____ m/min _____ 1/min

Feed (f) : _____ mm/rev. Feed (f_z) : _____ mm/tooth

5. Machine : _____ internal coolant

Working position : horizontal
 vertical

Tool attachment : collet
 hydraulic chuck

Weldon / Whistle Notch
 hot / cold shrunk

6. Lubricant : emulsion oil

air mist

Product : _____

7. Tool change reason : tool wear

tool breakage

incorrect threading (inspected with gauge)

programme error

8. Efficiency comparison

Tool under test : _____

Performance and observations : _____

Remarks : _____

LIEFER- UND ZAHLUNGSBEDINGUNGEN

Bestellungen	<p>Bestellungen, die nicht ab Lager ausgeliefert werden können, sind von uns zu bestätigen.</p> <p>Artikel, die nicht mehr standardmässig hergestellt werden, obwohl sie im Katalog aufgeführt sind, müssen als Spezialanfertigung angeboten und berechnet werden.</p> <p>Aufträge können nur nach gegenseitiger schriftlicher Abmachung annulliert werden.</p>
Angebote und Auftragsbestätigungen	<p>Die zu unseren Angeboten gehörenden Beschreibungen und Unterlagen, wie Gewichts- und Massangaben, Abbildungen und Zeichnungen, sind durch die ständige Weiterentwicklung nur annähernd massgebend, sofern sie nicht als verbindlich bezeichnet sind.</p>
Preise	<p>Unsere Preise verstehen sich exklusive MWSt, für Lieferung ab Werk, ausschliesslich Verpackung, Versandkosten und Versicherung.</p> <p>Im Falle einer Preiserhöhung behalten wir uns das Recht vor, bereits bestätigte Werkzeuge zu den neuen Preisen zu verrechnen.</p>
Zahlungen	<p>Unsere Rechnungen sind innert 30 Tagen netto zahlbar. Bei Zielüberschreitungen werden Verzugszinsen nach dem jeweils gültigen Diskontsatz verrechnet. Die Kosten für Lieferungen per Nachnahme, Wechselspesen, usw. gehen zu Lasten des Käufers.</p>
Eigentumsvorbehalt	<p>Wir behalten uns das Eigentum an der jeweils gelieferten Ware bis zur vollständigen Bezahlung des Kaufpreises, einschliesslich aller Nebenkosten, vor.</p>
Versand	<p>Erfolgt auf Rechnung und Gefahr des Bestellers.</p>
Lieferfristen	<p>Die Lieferfristen werden jeweils sorgfältig ermittelt, sind jedoch stets ohne Gewähr.</p> <p>Bei Überschreitung der bestätigten Lieferfrist lehnen wir Verzugsstrafen oder sonstige Schadenersatzforderungen, sowie Rücktritt von Bestellungen, grundsätzlich ab.</p>
Spezialanfertigungen	<p>Bei allen Lieferungen von Spezialwerkzeugen behalten wir uns das Recht einer Über- oder Unterschreitung der Bestellmenge um bis zu 15 %, bei kleinen Mengen um 1 bis 2 Stück, vor.</p>
Garantie	<p>Werkzeuge, die wir als fehlerhaft anerkennen, werden gratis ersetzt. Dies jedoch ohne jegliche weitere Entschädigung.</p>
Beanstandungen	<p>Müssen spätestens innert 14 Tagen nach Erhalt der Ware schriftlich angebracht werden.</p>
Zeichnungen und Abbildungen	<p>Es ist untersagt, Zeichnungen und Abbildungen zu kopieren oder Dritten zugänglich zu machen.</p> <p>Angaben in unserem Katalog, auf Zeichnungen und in anderen Dokumenten können sich infolge technischer Weiterentwicklung und eventueller neuer Normen ändern. Sie sind deshalb nicht verbindlich.</p>
Notstandsbedingungen	<p>In Fällen von höherer Gewalt, teilweisem oder totalem Unterbruch unserer Fabrikation, behalten wir uns das Recht vor, von eingegangenen Lieferverpflichtungen ganz oder teilweise zurückzutreten.</p>
Erfüllungsort und Gerichtsstand	<p>Für alle sich aus dem Vertragsverhältnis ergebenden Streitigkeiten ist das Amtsgericht Moutier (Schweiz) zuständig.</p> <p>Streitigkeiten unterstehen ausschliesslich dem Schweizerischen Obligationenrecht.</p>

DELIVERY AND PAYMENT CONDITIONS

Orders	Orders, which cannot be delivered from stock, will be acknowledged. Items, which do not belong any more to our standard programme, although still featured in the catalogue, will be invoiced as «specials». Orders may only be cancelled by mutual written agreement.
Quotations and acknowledgements	For reasons of constant development in this field, all descriptions mentioned in our quotations, annexed documents, weight indications, measurements as well as illustrations and drawings are approximate indications. These technical data have binding value only if expressly specified.
Prices	Our prices are quoted for deliveries ex works Malleray, excluding VAT, packing, insurance, freight, customs' and legalisation duties. Should prices increase, we reserve the right to invoice tools already acknowledged at the new prices.
Payment	Payments must be made in advance or against irrevocable and confirmed documentary credit to be opened in our favour with a Swiss bank. All banking commissions and charges have to be borne by the buyer.
Right of ownership	We reserve the right of ownership of all goods supplied until the sales price, plus all incidental charges, have fully been paid.
Despatch	Deliveries take place at the purchaser's risk.
Delivery	Confirmed delivery dates are non-binding. We will do our utmost to maintain them. However, we cannot accept responsibility of direct or consequential losses due to delayed deliveries.
Special orders	For all special tools we reserve the right to over or under supply the ordered quantity by up to 15 %, or on small quantities by 1 or 2 pieces.
Guarantee	Tools recognised to be defective by DC will be replaced free of charge, but without prejudice.
Complaints	Complaints will be considered only within 15 days after receipt of the goods.
Drawings and sketches	The reproduction or transmission of drawings and other documents to a third party are prohibited. The information (drawings and prints) in our catalogue is for guidance only and is not binding.
Special conditions	In the case of partial or total disruption of our production; we reserve the right to partially or totally cancel our delivery commitments.
Tribunal	All disputes are subject to Swiss Law. The seat of court of law will be Moutier (Switzerland).

ZUSCHLÄGE - PRICE SUPPLEMENTS

Zuschläge für Abänderungen von blanken Gewindebohren und Oberflächen-Behandlungen

	Auf Bruttopreis pro Stück	Anteil an Einrichtkosten pro Typ und Abmessung (netto)
Abändern des Spanwinkels (Ø 5 - 20 mm)	10 %	auf Anfrage
Verlängern des Anschnittes (bis Ø 20 mm)	10 %	auf Anfrage
Kürzen des Anschnittes (Ø 3 - 20 mm)	20 %	auf Anfrage
Schälanschnitt anschleifen (Ø 5 - 20 mm)	10 %	auf Anfrage
Abschleifen der Zentrierspitze	3 %	auf Anfrage
Verjüngen des Führungsgewindes ab Ø 4 mm	12 %	auf Anfrage
NV-Plasmanitrierung + "V"-Oberflächenbehandlung	10 %	auf Anfrage
DC-"V"-Oberflächenbehandlung	8 %	auf Anfrage
Zusätzliche Markierung	5 %	auf Anfrage
Kühlkanal, mit stirnseitigem Schmiermittelaustritt	auf Anfrage	auf Anfrage
Kühlkanal, mit seitlichem Schmiermittelaustritt	auf Anfrage	auf Anfrage
Beschichtungen TiN, TiCN, VS, CrN, HL	auf Anfrage	auf Anfrage

Price supplements for modifications for bright finished taps and surface treatments

	On gross price each	Participation of set-up costs per type and size (net)
Modification of cutting angle (Ø 5 - 20 mm)	10 %	on request
Lengthening of chamfer (up to Ø 20 mm)	10 %	on request
Shortening of chamfer (Ø 3 - 20 mm)	20 %	on request
Grinding of peeling cut (Ø 5 - 20 mm)	10 %	on request
Removal of centre point	3 %	on request
Truncated thread from Ø 4 mm	12 %	on request
NV-Plasma nitriding + "V" surface treatment	10 %	on request
DC "V" surface treatment	8 %	on request
Additional marking	5 %	on request
Internal coolant, with frontal outflow	on request	on request
Internal coolant, with radial outflow	on request	on request
Coatings TiN, TiCN, VS, CrN, HL	on request	on request

Kosten für Prüfzertifikate - Prices for gauge test certificates

Für neue Gewindelehren (Neulieferung) / Messunsicherheit U95

For new ordered thread gauges / Measuring uncertainty U95

		Nettopreise / Net prices	
D5703	D5725	Ø 1 - 2.9 mm	auf Anfrage / on request
		Ø 3 - 40 mm	auf Anfrage / on request
D5701-1	D5701-2	Ø 1 - 2.9 mm	auf Anfrage / on request
		Ø 3 - 40 mm	auf Anfrage / on request
		Ø 41 - 80 mm	auf Anfrage / on request
		Ø 81 - 200 mm	auf Anfrage / on request
D5704	D5714	Ø 1 - 2.9 mm	auf Anfrage / on request
		Ø 3 - 40 mm	auf Anfrage / on request
		Ø 41 - 80 mm	auf Anfrage / on request
		Ø 81 - 200 mm	auf Anfrage / on request
D5720 / D5721	D5722 / D5723	Ø 3 - 40 mm	auf Anfrage / on request
		Ø 41 - 80 mm	auf Anfrage / on request
		Ø > 80 mm	auf Anfrage / on request

Alle zertifizierten Gewindelehren werden mit der auf dem entsprechenden Prüfzertifikat aufgeführten Identnummer beschriftet.

All "certified" gauges will be marked with the identity number of the corresponding test certificate.

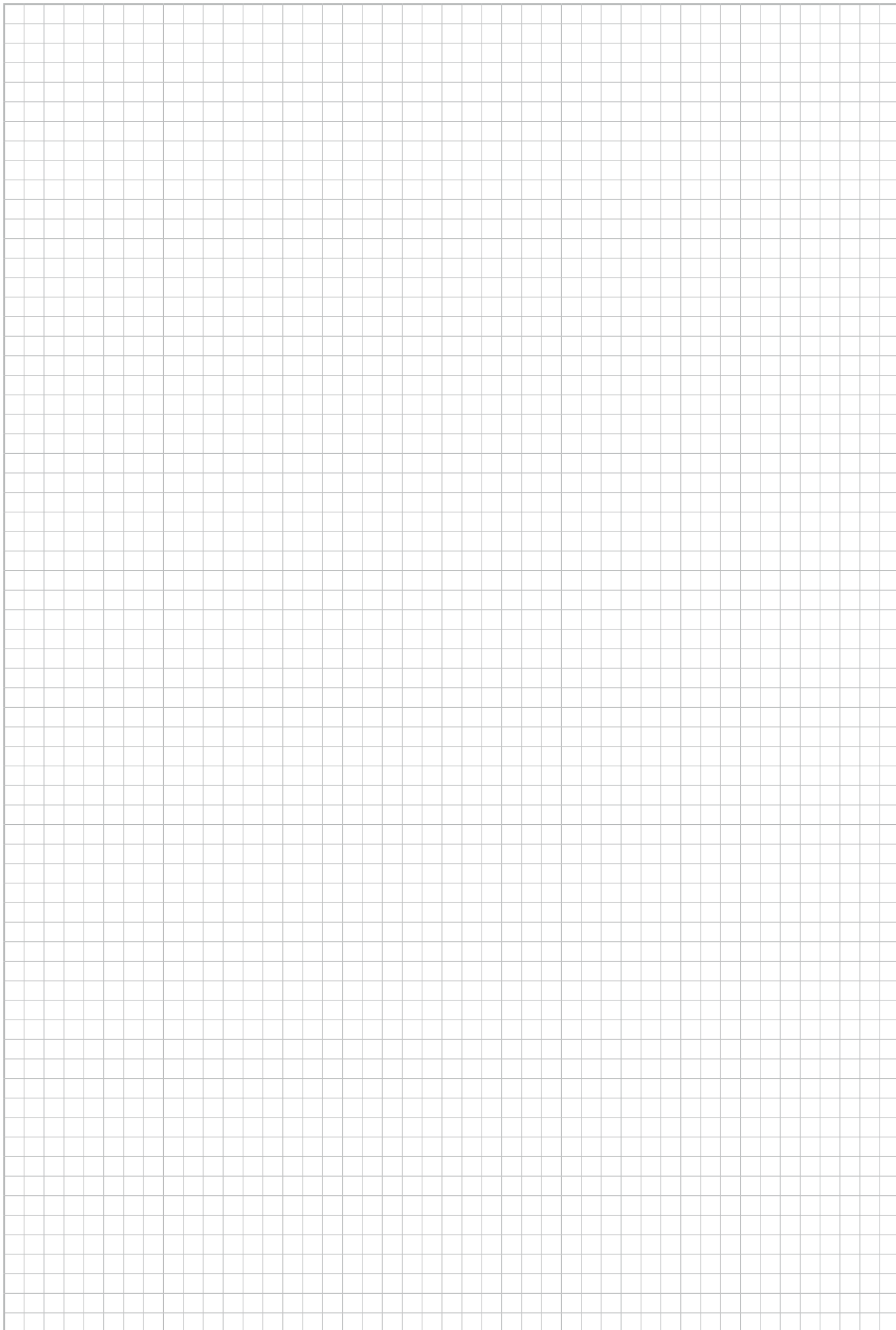



DC SWISS SA

CH-2735 Malleray

Tel. +41 32 491 63 63

Fax +41 32 491 64 64

E-mail: info@dcswiss.ch

DC SWISS GmbH

Graseggerstraße 125
DE-50737 Köln
Tel. +49 221 995 532-0
Fax +49 221 995 532-10
E-Mail: info@dcswiss.de

DC SWISS s.r.l.

Via Canova 10
IT-20017 Rho
Tel. +39 02 669 40 41
Fax +39 02 669 78 50
E-mail: info@dcswiss.it

DC SWISS UK Ltd

9 Orgreave Road
UK-Sheffield S13 9LQ
Tel. +44 114 2939013
Fax +44 114 2880936
E-mail: info@dcswiss.co.uk

Warnung

Gewindewerkzeuge können durch technisches Versagen oder durch Fahrlässigkeit brechen oder zersplittern und die Gesundheit des Mitarbeitenden gefährden. Befolgen Sie daher die gesetzlichen Sicherheits- und Gesundheitsvorschriften. Zudem ist das Tragen der Schutzbrille unerlässlich.

Das Schleifen von Gewindewerkzeugen verursacht gefährlichen Staub und darf nur unter gewissenhaftesten Sicherheitsrichtlinien verrichtet werden.

Warning

Thread tools can break or shatter either through technical failure or negligence, and can endanger the health of the operator. Always obey the safety and health regulations, also the wearing of safety glasses is compulsory.

The grinding of threading tools causes hazardous particles, and must be performed only under most rigorous safety standards.

Eventuelle Druckfehler technischer Daten oder zwischenzeitlich eintretende Änderungen jeder Art berechtigen nicht zu Ansprüchen.

Nachdruck von Text und Bildern, auch auszugsweise, ist nicht gestattet.

We have made every effort to ensure that the information (drawings, prints, technical data) given is correct. However, we do not assume any responsibility for any errors, omissions or subsequent changes.

The reproduction of drawings and other documents and their transmission to a third party is prohibited.

